Contents

Section 2: Electrical - Switches, Solenoids and Motors	2-3
Switches	2-3
Switches “A”, “B”, “C” and “D”	2-4
Error Codes “A” Switch	2-4
Error Codes “B” Switch	2-4
Error Codes “C” Switch	2-5
Codes “D” Switch	2-5
Elevator Control Switch (EC)	2-6
Error Code “EC” Switch	2-6
Switch “G”	2-7
Error Codes “G” Switch	2-7
Mechanic’s Rear Control Switches	2-8
Out-Of-Range Switch	2-9
Error Codes “OOR” Switch	2-9
Pin Holder Switches	2-10
Error Codes - Pin Loading and Detecting	2-10
Spotting Tong Switch (ST)	2-11
Error Codes “ST” Switch	2-11
Sweep Motor Switch (SM)	2-12
Error Codes “SM” Switch	2-12
TS-1 Switch	2-13
Error Code	2-13
TS-2 Switch	2-14
Error Code	2-14
Pin Count Switch	2-15
Error Code	2-15
Solenoids	2-16
Ball Door Solenoid	2-18
Sweep Release Solenoid	2-19
Stroke Limiter Solenoid	2-20
Spotting Tong Solenoid	2-21
Pin Holder Solenoids	2-22
Shark Solenoid	2-23

Motors	2-24
Distributor Motor	2-25
Sweep Motor	2-25
Table Motor	2-25
Ball Accelerator Motor	2-25

Section 2: Electrical - Switches, Solenoids and Motors

Switches

The GS Certified Pre-Owned pinsetter discussed in this manual contain 26 switches which are monitored by the Nexgen electronics to protect and control the pinsetter. If a switch is not functioning properly the machine will shut off and display an error code describing the failure.

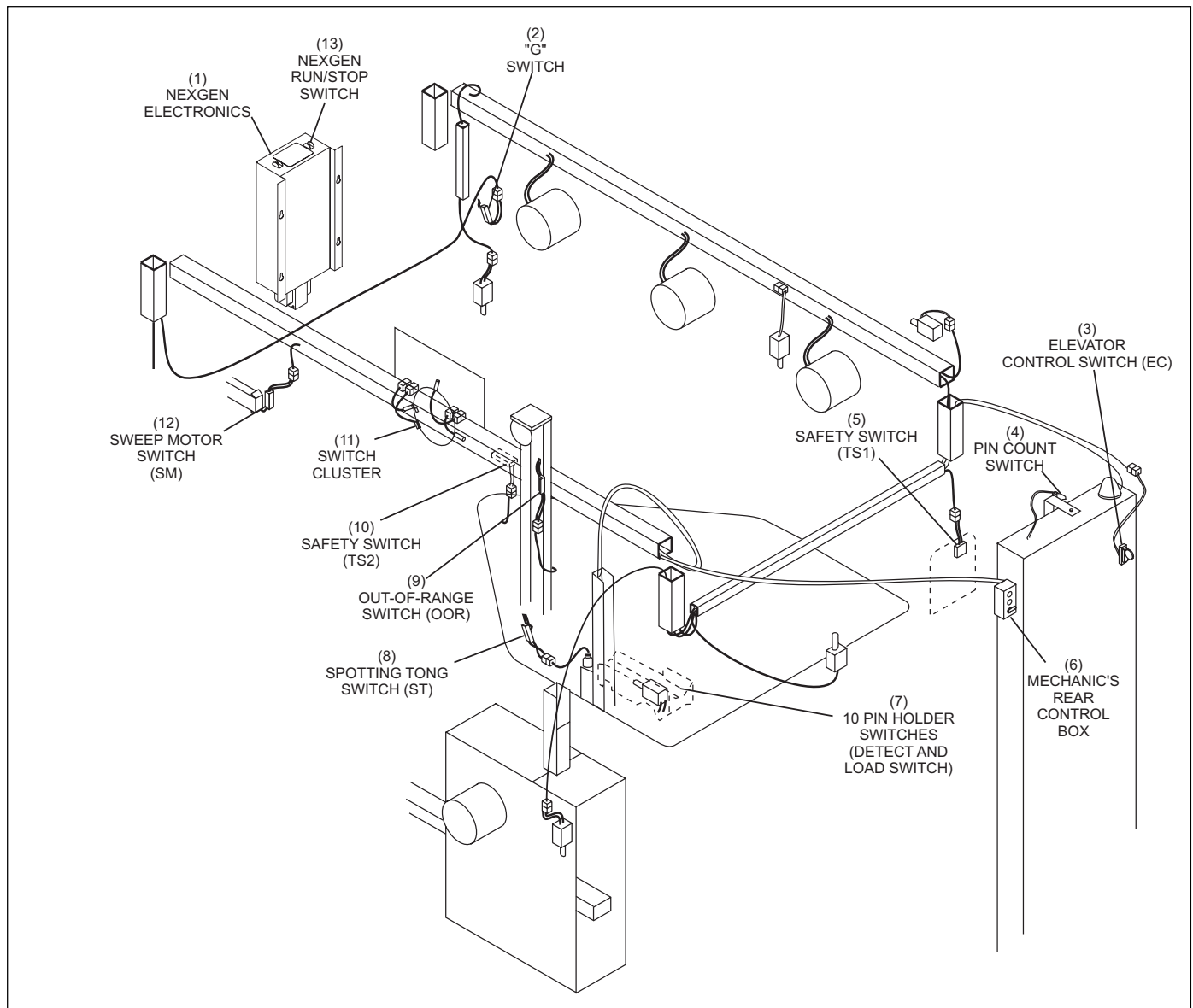

Figure 2-1. Switches.

- | | | |
|---|-------------------------------|----------------------------------|
| (1) NEXGEN ELECTRONICS | (2) "G" SWITCH | (3) ELEVATOR CONTROL SWITCH (EC) |
| (4) PIN COUNT SWITCH | (5) SAFETY SWITCH (TS1) | (6) MECHANIC'S REAR CONTROL BOX |
| (7) 10 PIN HOLDER SWITCHES (DETECT AND LOAD SWITCH) | (8) SPOTTING TONG SWITCH (ST) | (9) OUT-OF-RANGE SWITCH (OOR) |
| (10) SAFETY SWITCH (TS2) | (11) SWITCH CLUSTER | (12) SWEEP MOTOR SWITCH (SM) |
| (13) NEXGEN RUN/STOP SWITCH | | |

Switches "A", "B", "C" and "D"

These switches are mounted on a switch cluster housing located inside the right frame of the pinsetter. The primary function of the switch cluster is to inform the Pinsetter CPU of the position of the setting table. The "A" switch is a microswitch that is held closed by an actuator when the table is up in the home position. A magnet mounted on the end of the actuator will close the contacts in the "B," "C" and "D" switches as the table is being lowered or raised.

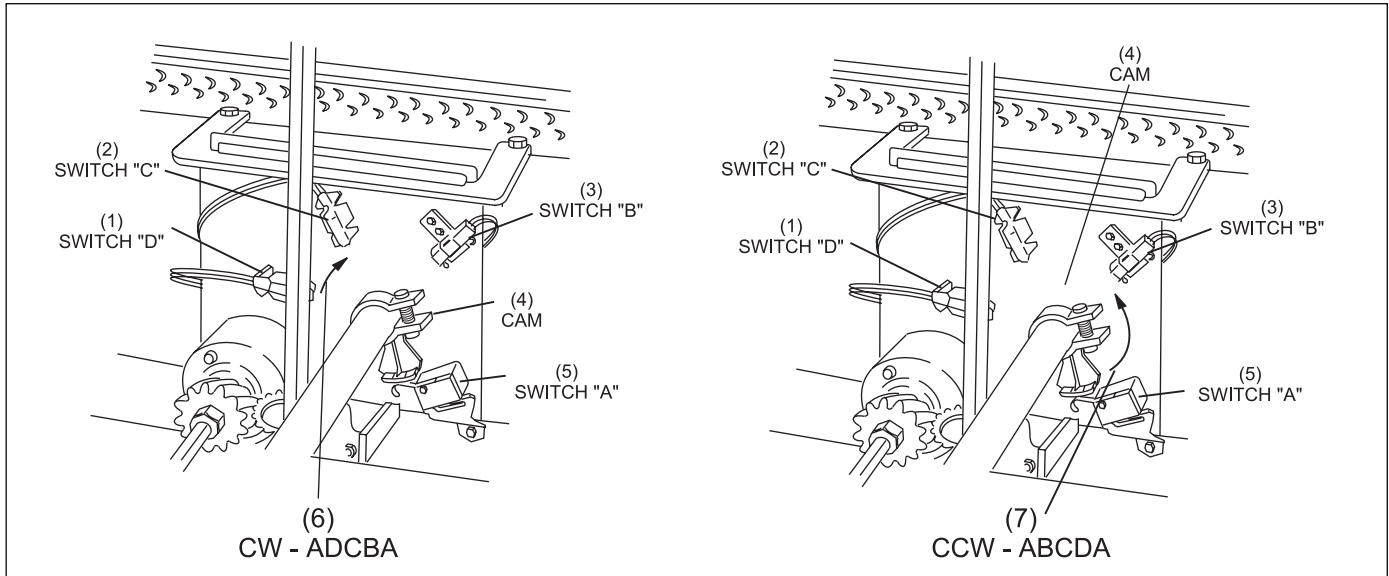

Figure 2-2. Switch Cluster.

- | | | |
|------------------------------|----------------|-----------------------|
| (1) SWITCH "D" | (2) SWITCH "C" | (3) SWITCH "B" |
| (4) CAM | (5) SWITCH "A" | (6) CLOCKWISE - ADCBA |
| (7) COUNTERCLOCKWISE - ABCDA | | |

Error Code "A" Switch

A FOUND	60	SWITCH A NOT EXPECTED BUT FOUND
A NTFND	70	SWITCH A EXPECTED BUT NOT FOUND
Invid Q - Invid 5	90-95	INVALID MACHINE STATE

Error Code "B" Switch

B FOUND	61	SWITCH B NOT EXPECTED BUT FOUND
B NTFND	71	SWITCH B EXPECTED BUT NOT FOUND

Error Code "C" Switch

C FOUND	62	SWITCH C NOT EXPECTED BUT FOUND
C NTFND	72	SWITCH C IS EXPECTED BUT NOT FOUND

Code "D" Switch

D FOUND	63	SWITCH D NOT EXPECTED BUT FOUND
D NTFND	73	SWITCH D EXPECTED BUT NOT FOUND

Elevator Control Switch (EC)

The EC switch is located on the left rear frame of the elevator. It is pulsed by rollers on the pin shovel shaft as the shovels are moving. If it is not pulsed at least once every six seconds, the Pinsetter CPU determines that the elevator is either jammed or a drive belt is slipping or some other defect is preventing the switch from being pulsed properly and the machine will be switched off.

- (1) SHOVEL DRIVE CHAIN
- (2) EC SWITCH
- (3) SHOVEL ROLLER

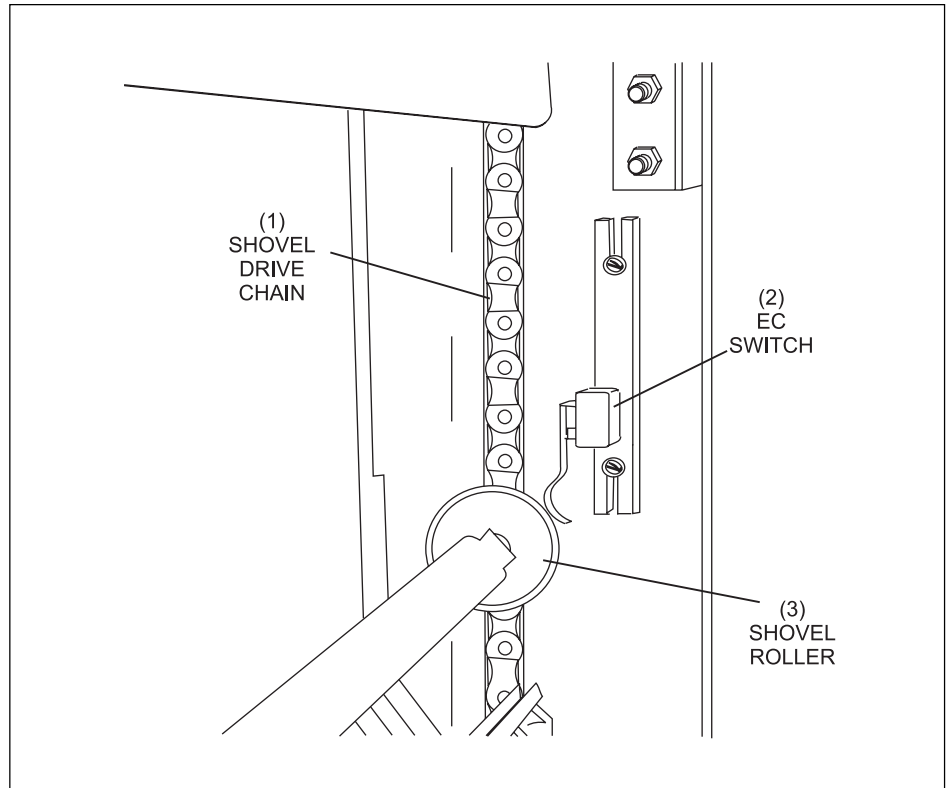

Figure 2-3. Shovel Roller Pulsing EC Switch.

Error Code "EC" Switch

ElevJam	EJ	ELEVATOR JAM
---------	----	--------------

Switch "G"

This "G" switch is located under the attenuator on the front left side of the pinsetter. This switch is actuated by the attenuator when the sweep is all the way down in the guarding position. The switch must be actuated before the table can be lowered.

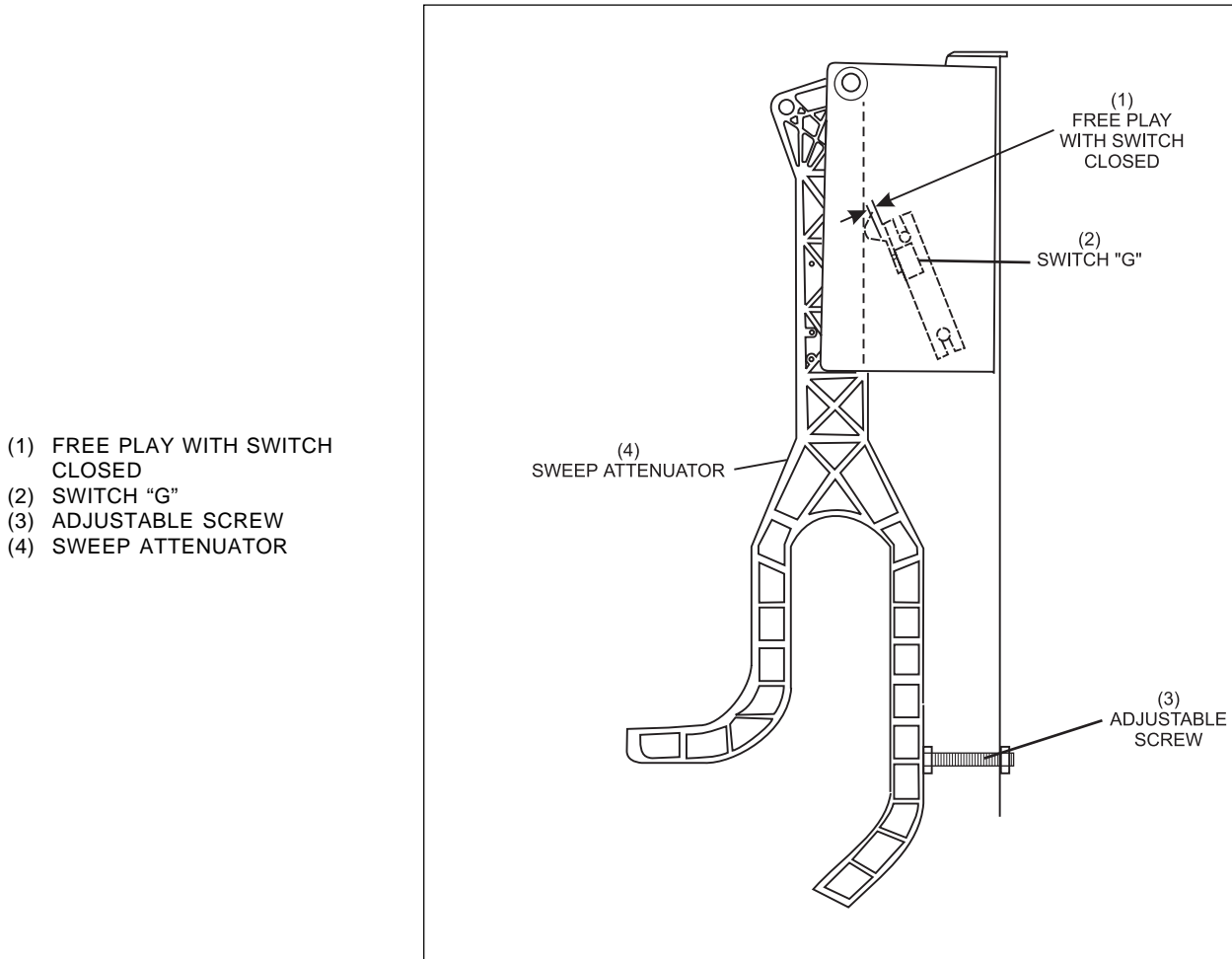

Figure 2-4. Attenuator Down, Closing "G" Switch.

Error Code "G" Switch

G FOUND	65	SWITCH G IS NOT EXPECTED BUT FOUND
G NTFND	75	SWITCH G EXPECTED BUT NOT FOUND
Invlđ 0 - Invlđ 5	90-95	INVALID MACHINE STATE

Mechanic's Rear Control Switches

A mechanic's rear control box mounted on the side of the elevator gives the mechanic operational control of the pinsetter. Three switches are located on this box:

1. **Set Switch** - This switch causes the machine to set the last known combination of pins on the pin deck.
2. **Reset** - This switch cycles the machine to the next ball.
3. **Stop/Run** - This switch turns off the machine. It must be pin deck in the stop position before entering the machine for service.

NOTE: The reset switch will act like the set switch in league or tournament mode when the pinsetter is connected to Brunswick Framework, and /or Vector scoring. This is done to keep the pinsetter in sync with the automatic scorer.

These three switches are identical in function to the switches mounted on the top of the Nexgen box located on the front of the pinsetter.

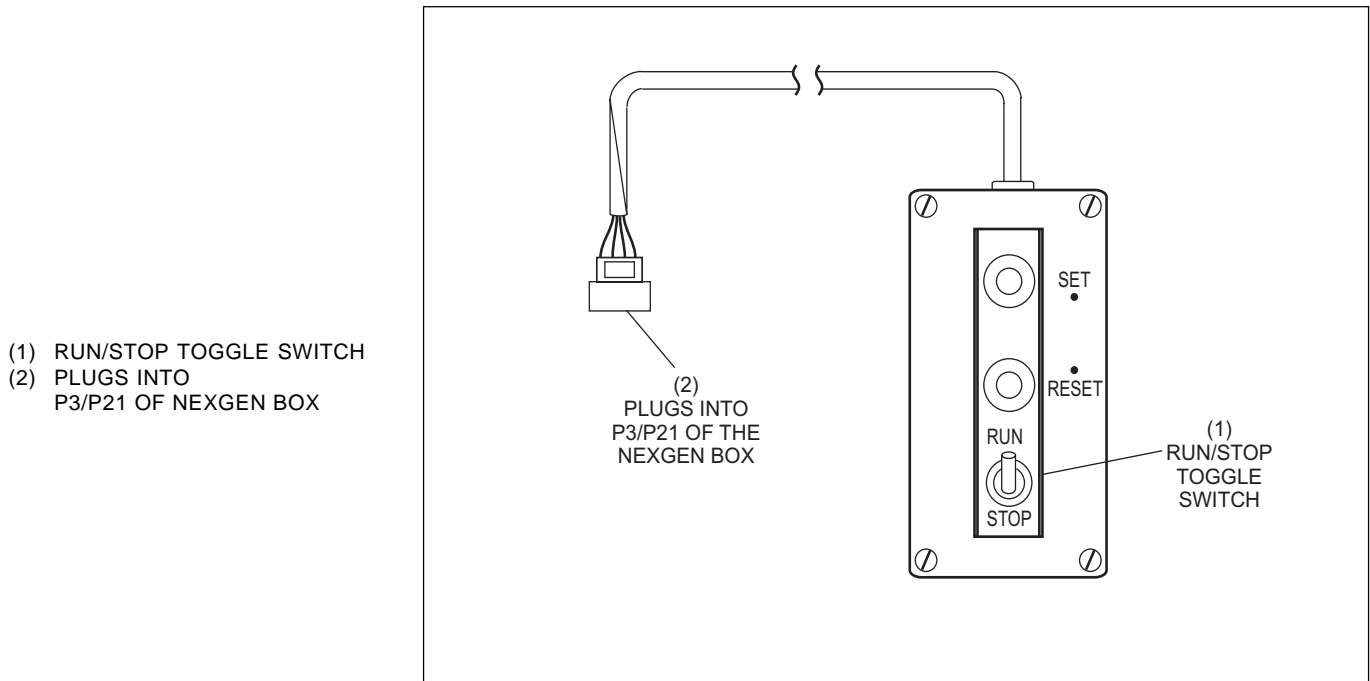

Figure 2-5. Mechanic's Rear Control Box.

Out-Of-Range Switch

The “OOR” switch is located on the right hand guide tower. The purpose of this switch is to inform the Pinsetter CPU if the table was able to lower to the normal detecting height. If a pin is moved out of range, the table will land on top of the pin causing the table to stop short of the switch. The pinsetter will complete its detection stroke and then turn off. The mechanic must then turn off the Stop/Run switch, clear any deadwood from the pin deck, and then turn the Stop/Run switch back to the Run position.

NOTE: This switch will be ignored if the pinsetter is connected to Brunswick Framework scoring that is in the open play mode.

NOTE: The Out-Of-Range function can also be disabled through the Nexgen electronics.

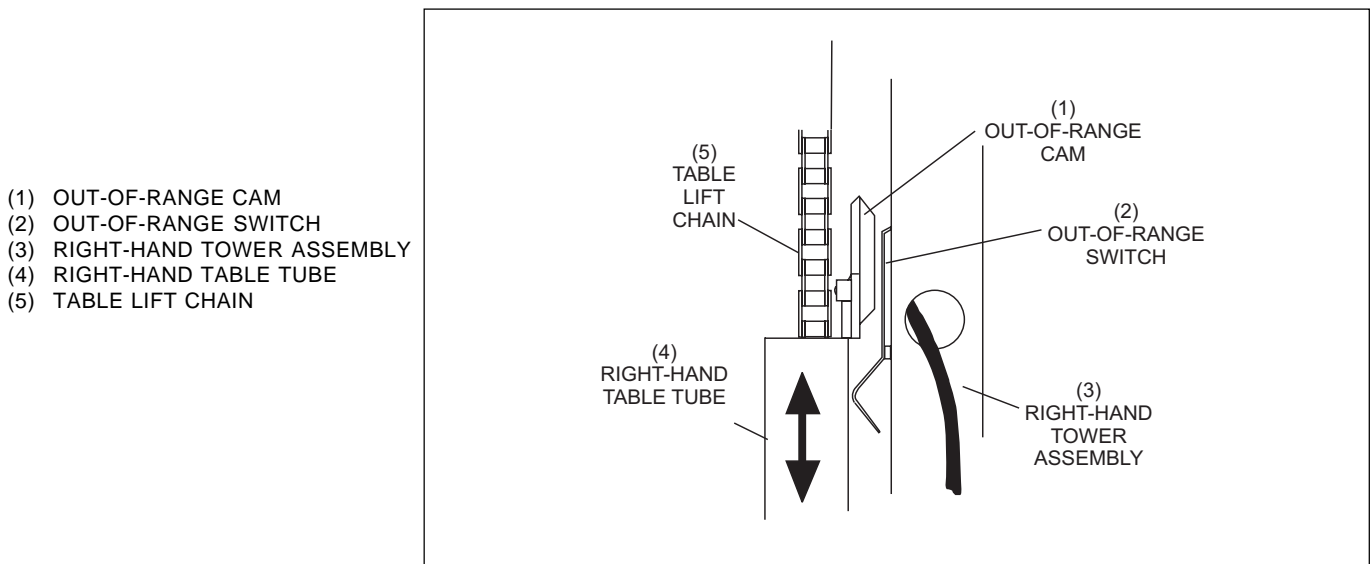

Figure 2-6. Out-Of-Range Switch.

Error Code “OOR” Switch

OOR Found	67	SW. OOR IS NOT EXPECTED BUT FOUND
Pin OOR	PO	OUT OF RANGE PIN DETECTED

Pin Holder Switches

The setting table has ten pin holders. Each pin holder has a single switch that is used for two purposes. The switch will be actuated by the pin dropping into the holder from a pin station. The switch can also be activated by the pin detector plate being pushed up during detection of a standing pin.

During operation, the Pinsetter CPU “memorizes” the pin holders’ switch positions as the table starts to lower. When the table reaches the “B” switch position, the Pinsetter CPU will read the switches again. If there is a pin already loaded into the pin holder, the detection of a standing pin will cause the switch to reopen. When detecting a standing pin without a pin loaded into the pin holder, the switch will close. A change to the switch allows the CPU to determine which pins, if any, are standing on the pin deck. The CPU uses this information to determine how to complete the cycle and what score to send to the scorer (if installed).

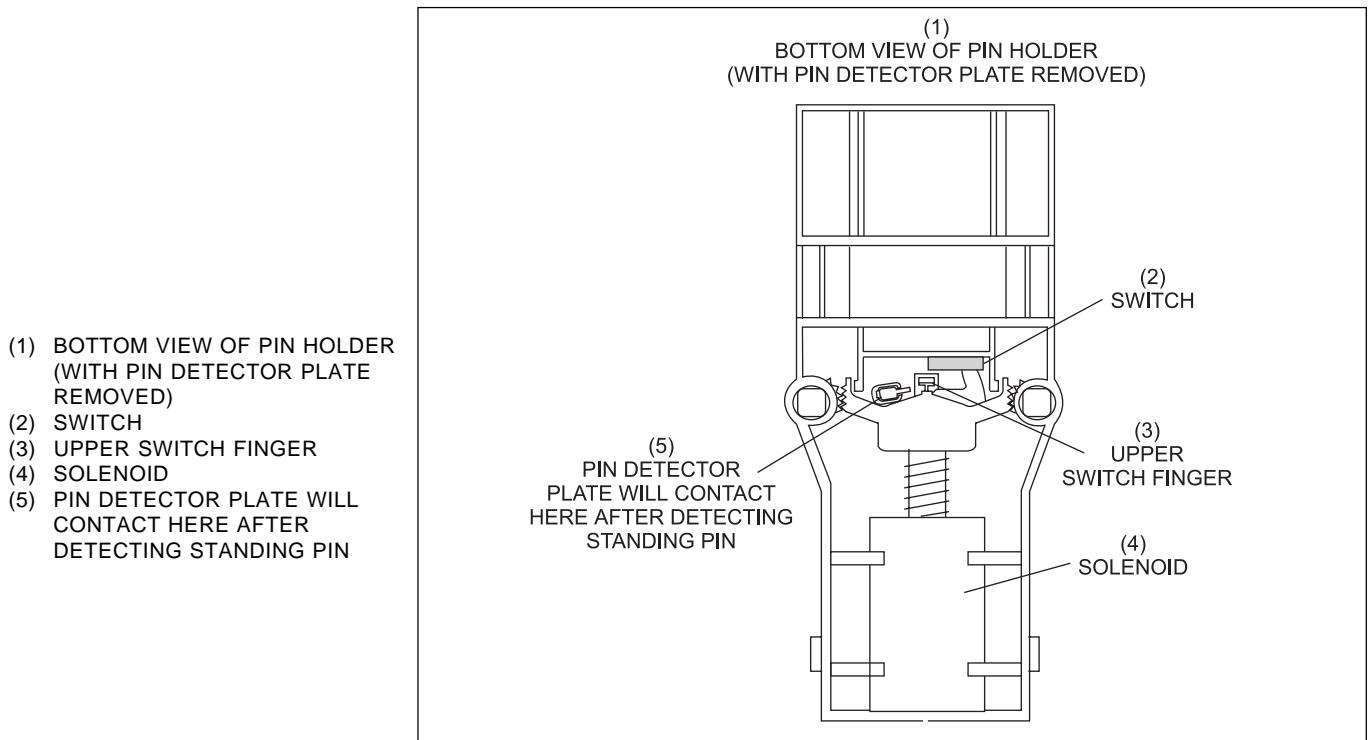

Figure 2-7. Pin Holder Detecting.

Error Codes - Pin Loading and Detecting

Pin1ld - Pin10ld	01-10	PIN LOADING TIME-OUT
Detect 1 - Detect 10	50-59	PIN NOT DETECTED IN DIAGNOSTICS

Spotting Tong Switch (ST)

The “ST” switch is located on the right side of the setting table. It lets the Pinsetter CPU know if the tongs are in the open position. A small cam on the toothed rack will activate this switch when the spotting tongs are open.

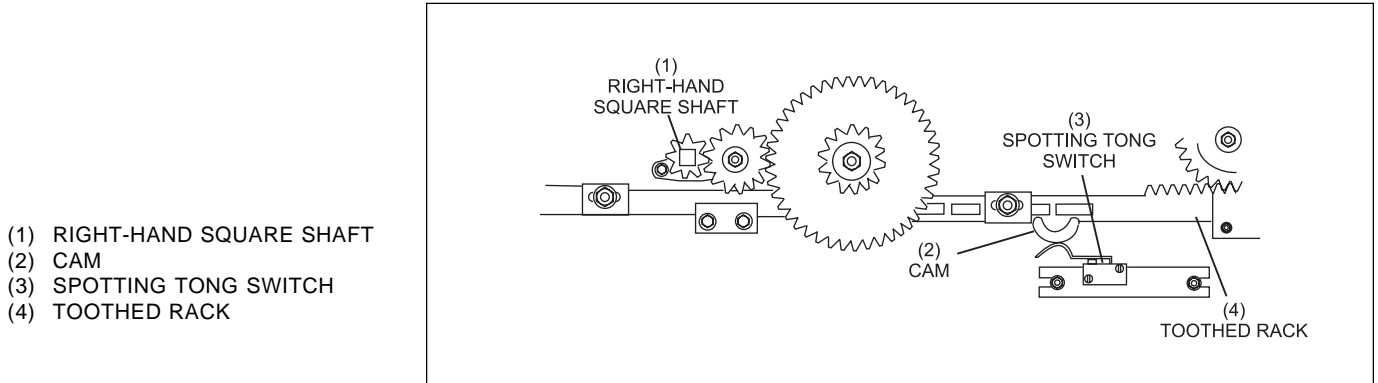

Figure 2-8. ST Switch with Tongs Open.

Error Codes “ST” Switch

ST Found	66	SWITCH ST NOT EXPECTED BUT FOUND
ST Ntfnd	76	SWITCH ST EXPECTED BUT NOT FOUND
Invlđ 0 - Invlđ 5	90-95	INVALID MACHINE STATE

Sweep Motor Switch (SM)

This switch is mounted on the right side of the pinsetter. A cam mounted on the sweep crank arm will close this switch when the sweep wagon is all the way forward. Activating this switch will turn the sweep motor off and allow the brake to stop the sweep before the table can be lowered.

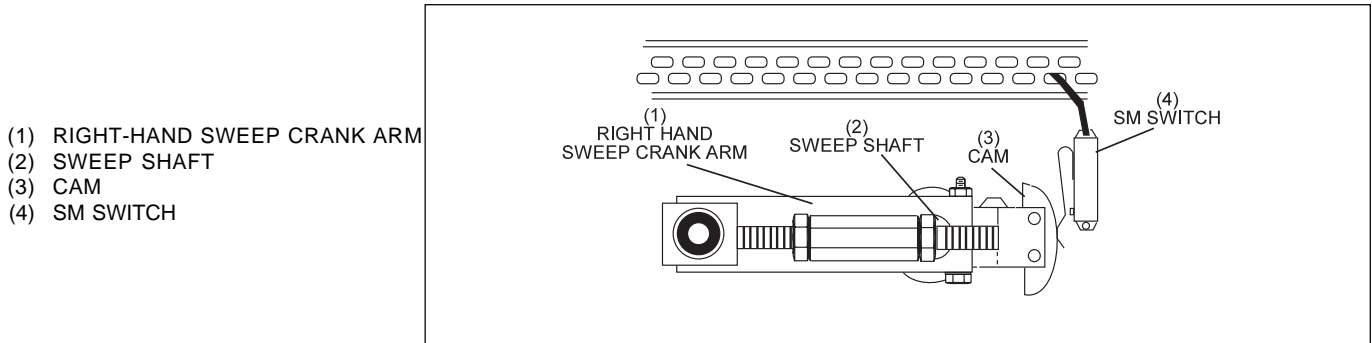

Figure 2-9. SM Switch.

Error Codes "SM" Switch

SM Found	64	SWITCH SM NOT EXPECTED BUT FOUND
SM Ntfnd	74	SWITCH SM EXPECTED BUT NOT FOUND
Invlđ 0 - Invlđ 5	90-95	INVALID MACHINE STATE

TS-1 Switch

The “TS-1” table safety switch is mounted on the back left side of the pinsetter frame. The switch is activated only when the pin holders are unable to return to the horizontal position after setting new pins. A roller on the rear swing shaft of the setting table overpowers a spring tensioned actuator arm to close this switch. Once this switch is actuated, the table motor will reverse the table for 1.5 seconds or until the “C” switch is closed. An error code “J1” or “TS1 Jam” will appear on the display on top of the Pinsetter electrical box and the trouble light will flash. The mechanic can then turn the stop/run switch of the machine to the stop position and clear the jam. Once the jam has been cleared, simply turn the stop/run switch to the run position to continue machine operation.

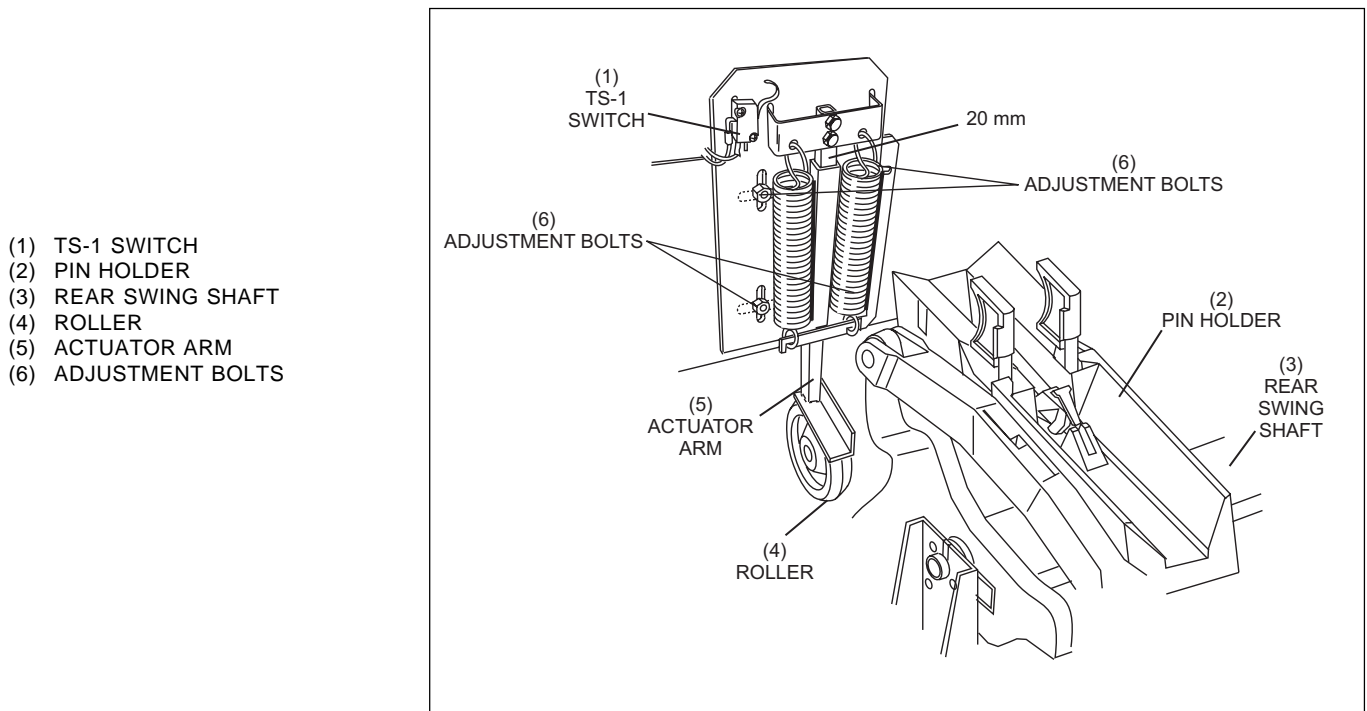

Figure 2-10. TS-1 Switch.

Error Code

TS1 Jam	J1	JAM SWITCH TS1 (REAR LEFT OF SETTING TABLE)
---------	----	---

TS-2 Switch

This table safety switch is mounted inside the right side frame near the switch cluster. This is a jam switch that is activated only when the table is not able to return to its up home position. If a pin or broken part becomes wedged between the top of the setting table and the bottom of the distributor, the table is prohibited from rising. As the table crank continues to turn, additional torque causes the chain sprocket and shaft to overpower a tension spring attached to the actuator lever. Any time this switch is closed, the table motor will reverse the table for 1.5 seconds or until the “C” switch is closed. An error code “J2” or TS2 JAM will appear on the display on top of the pinsetter electrical box. The trouble light will flash.

Turn the Stop/Run switch to the Stop position and clear the jam. Once the jam has been cleared, turn the stop/run switch to the run position.

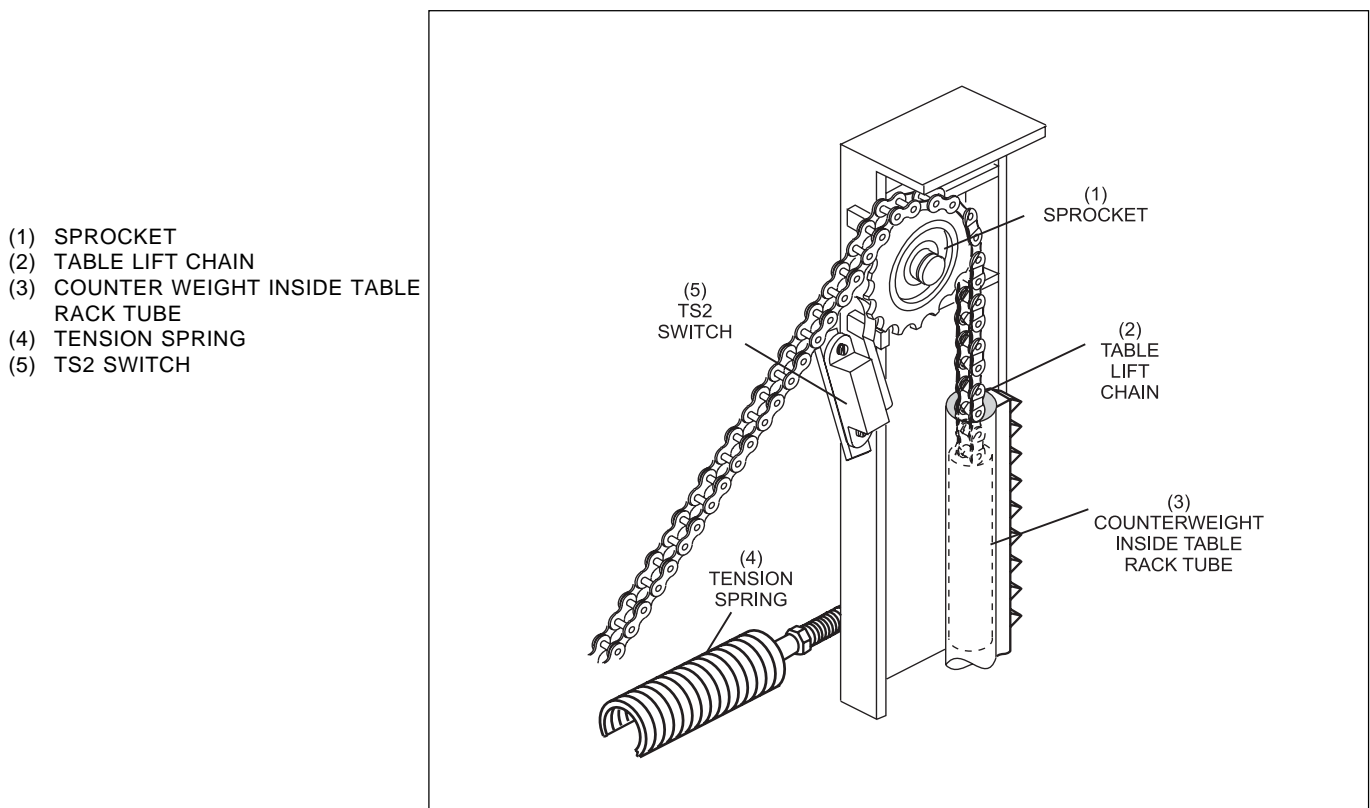

Figure 2-11. TS-2 Switch.

Error Code

TS2 Jam	J2	JAM SWITCH TS2 (TOWER)
---------	----	------------------------

Pin Count Switch

This switch is mounted on the top of the Elevator. The switch is positioned to count each pin as it leaves the elevator and enters the shark assembly. The switch information is sent to the pinsetter electronics where it is used to determine when to energize the shark solenoid.

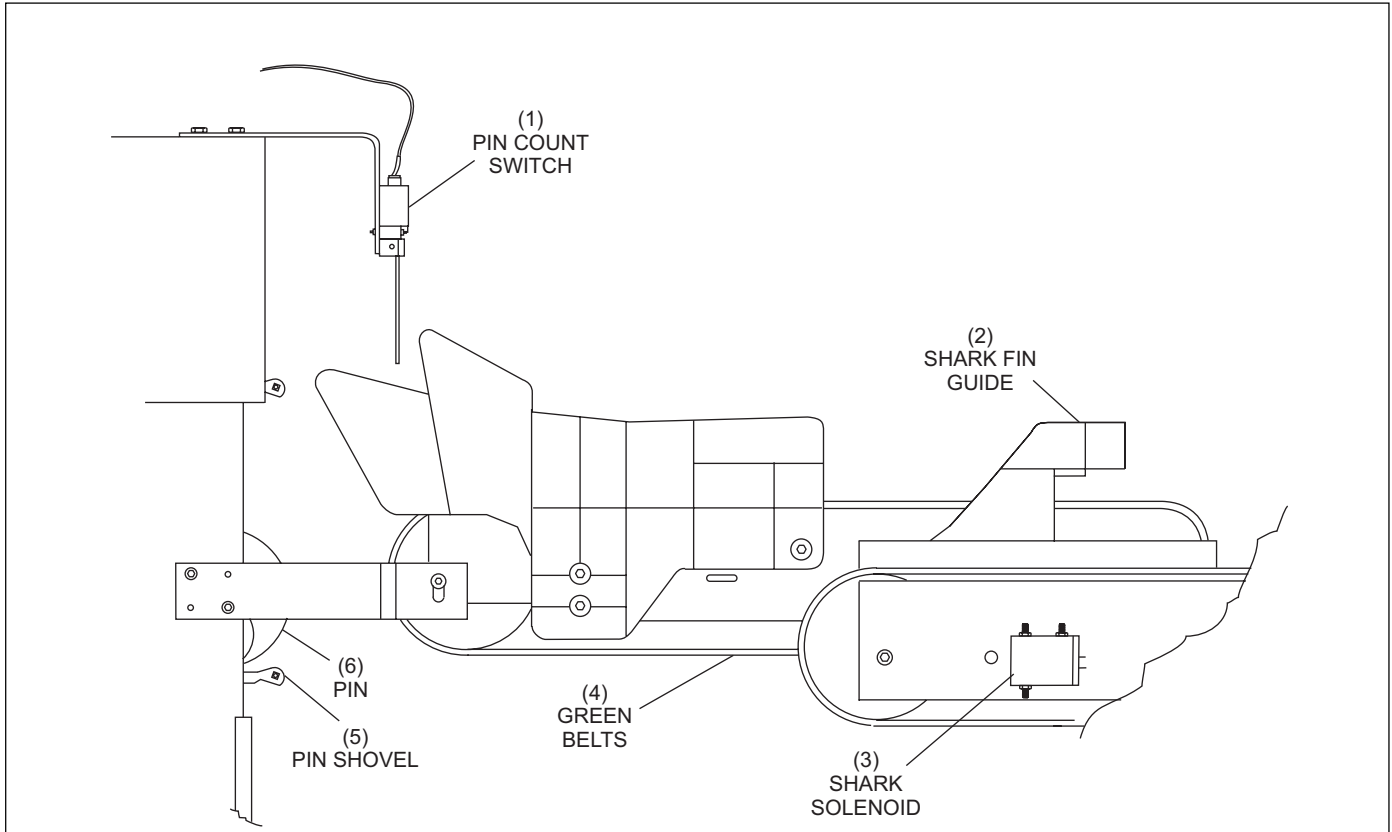

Figure 2-12. Pin Count Switch and Shark Solenoid.

(1) PIN COUNT SWITCH
(4) GREEN BELTS

(2) SHARK FIN GUIDE
(5) PIN SHOVEL

(3) SHARK SOLENOID
(6) PIN

Error Code

Pin cnt	EL	PIN COUNT SWITCH SHORTED FOR AT LEAST 5 SECONDS
Pin Ld3, Pin Ld6, Pin Ld9, or Pin Ld10	03, 06, 09, OR 10	PIN COUNT SWITCH WIRES OPEN

Solenoids

Two types of solenoids are used on the GS Certified Pre-Owned pinsetter. The black colored solenoids are intermittent duty type solenoids. This type of solenoid is pulsed only for a brief amount of time. The red colored solenoids are continuous duty type solenoids. This type of solenoid can be energized for 90 seconds at a time, if necessary.

***NOTE:** When working properly, the black function solenoid coils will have 12 ohms of resistance while the red solenoid coils will have 26 ohms of resistance.*

When troubleshooting solenoids, a reading on the multimeter of 0 ohms indicates that the solenoid has shorted out and is defective. A reading of infinity (no reading) indicates that the coil is opened and defective.

When changing a solenoid, always use a solenoid of the same duty type. Do not use a black colored solenoid in place of a red colored solenoid.

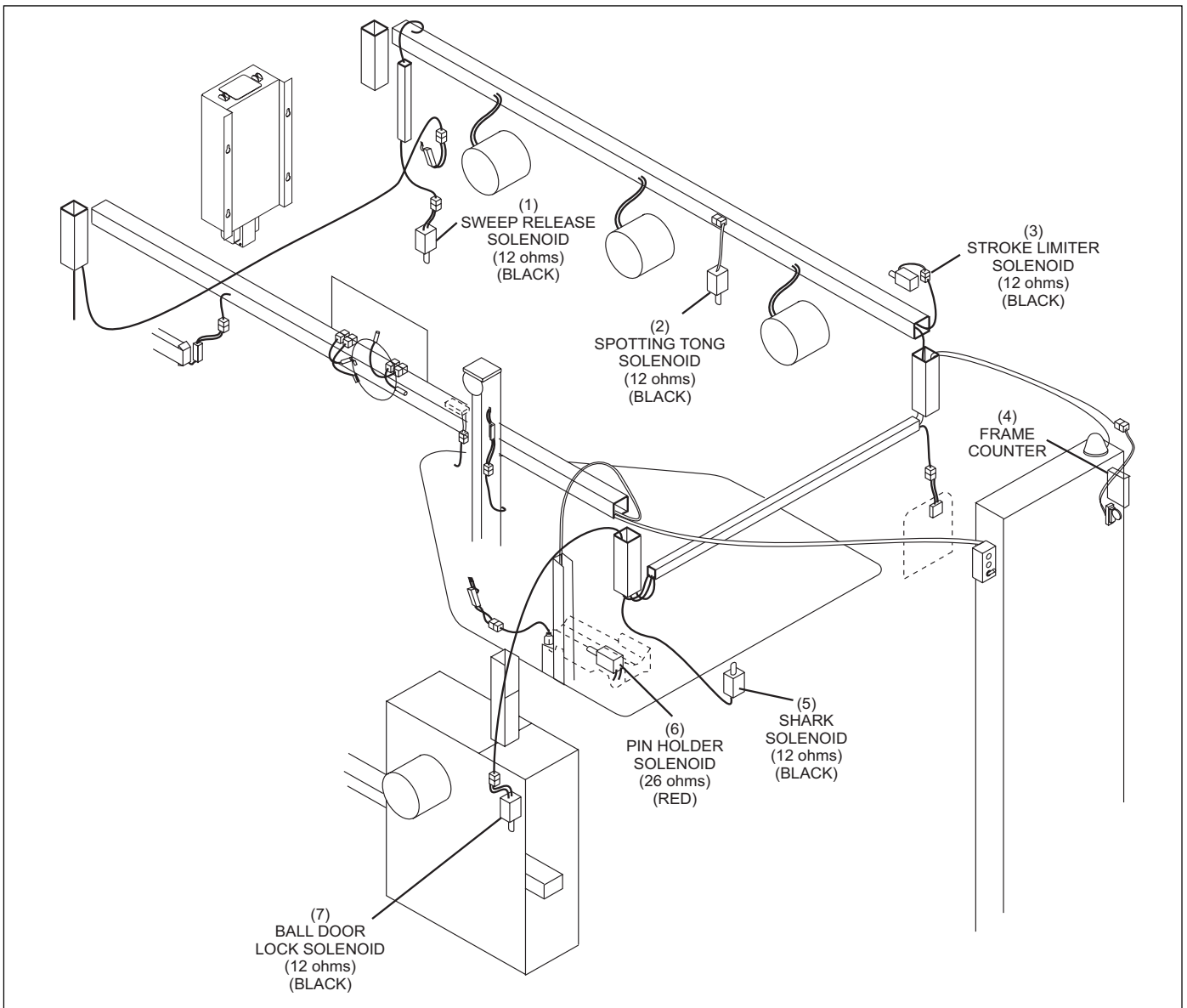

Figure 2-13. Solenoids.

- (1) SWEEP RELEASE SOLENOID
(12 OHMS) (BLACK)
- (4) FRAME COUNTER
- (7) BALL DOOR LOCK SOLENOID
(12 OHMS) (BLACK)

- (2) SPOTTING TONG SOLENOID
(12 OHMS) (BLACK)
- (5) SHARK SOLENOID (12 OHMS)
(BLACK)

- (3) STROKE LIMITER SOLENOID
(12 OHMS) (BLACK)
- (6) PIN HOLDER SOLENOID
(26 OHMS) (RED)

Ball Door Solenoid

The ball door solenoid energizes for three seconds upon ball detect. This drives the locking bolt downward, blocking the door button lever thus prohibiting the door from opening.

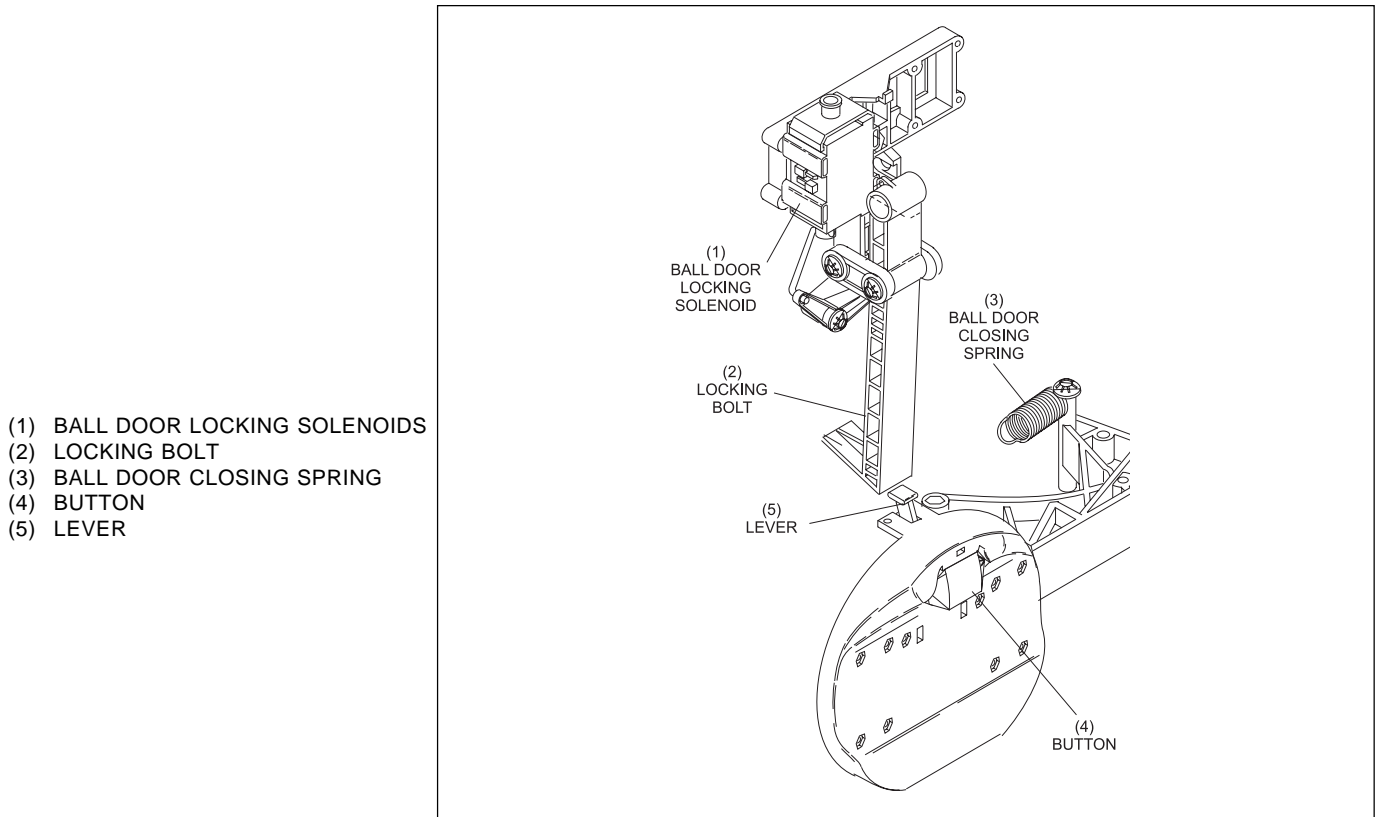

Figure 2-14. Ball Door Solenoid.

Sweep Release Solenoid

The purpose of the sweep release solenoid is to actuate the sweep release mechanism. This allows the tipper to pivot and the sweep wagon to lower from its up home position to the guarding position. It is energized immediately when a ball passes through the ball detector's beam or someone presses a "set" or "reset" button.

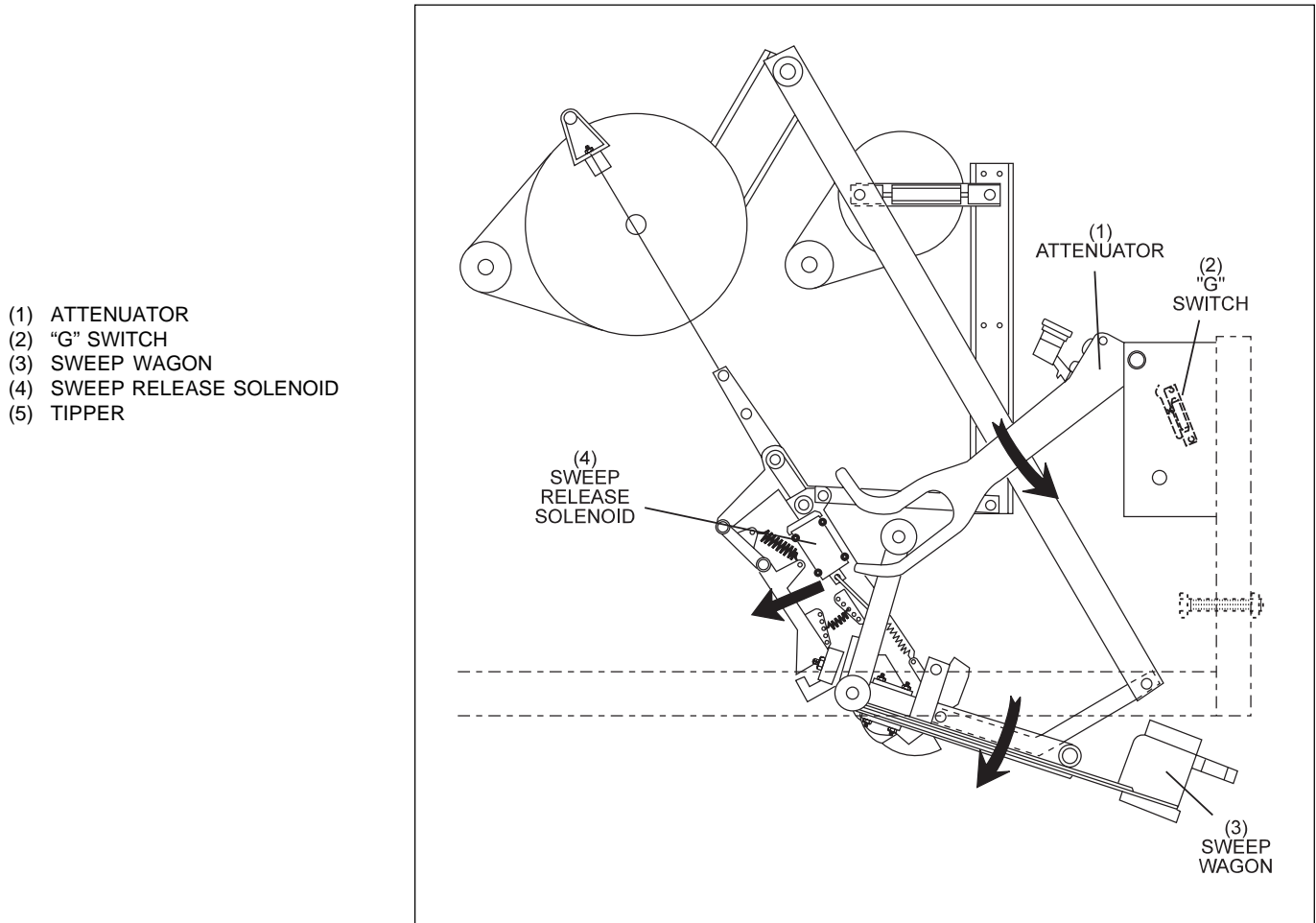

Figure 2-15. Sweep Release Solenoid.

Stroke Limiter Solenoid

The purpose of the stroke limiter solenoid is to briefly pull the stroke limiter plate away from the table tube allowing the T-stop to clear the stroke limiter plate and the table to lower fully to the pin deck. It also turns the left-hand square shaft, releasing the pin holder's swing shaft latch to allow the pin holders to go vertical as the table is lowering.

- (1) LEFT-HAND SQUARE SHAFT
- (2) STROKE LIMITER PLATE
- (3) T-STOP
- (4) STROKE LIMITER SOLENOID

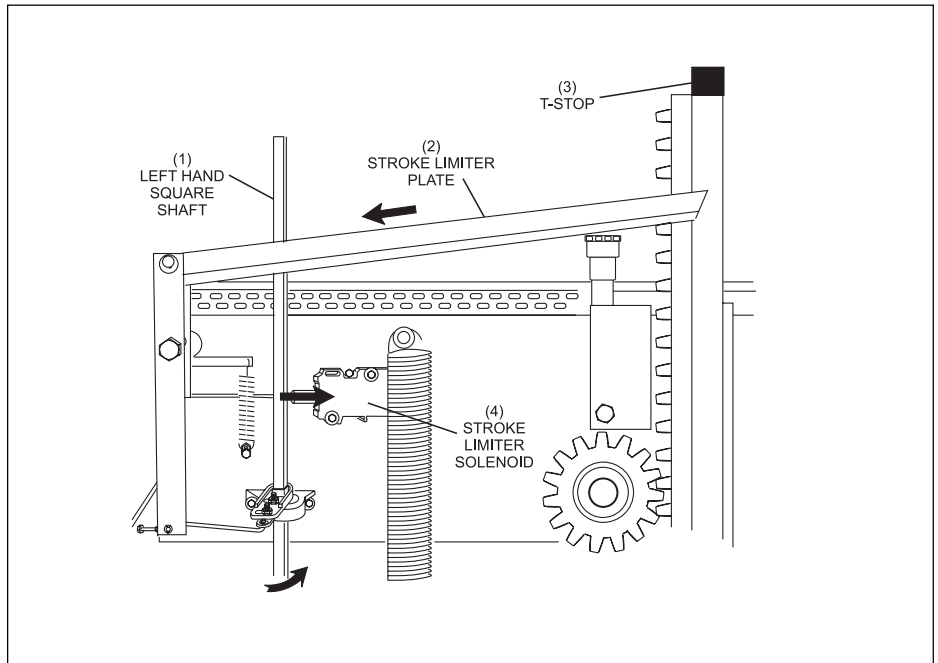

Figure 2-16. Stroke Limiter Solenoid.

Spotting Tong Solenoid

The spotting tong solenoid engages a gear clutch assembly with the table drive gear to close or reopen the spotting tongs depending on which direction the motor is turning. The gear clutch assembly rotates a spindle shaft, turning a helical gear driving the right-hand square shaft. When the main table drive shaft and right-hand square shaft are turning counterclockwise, the spotting tongs close. When they are turning clockwise, the spotting tongs open.

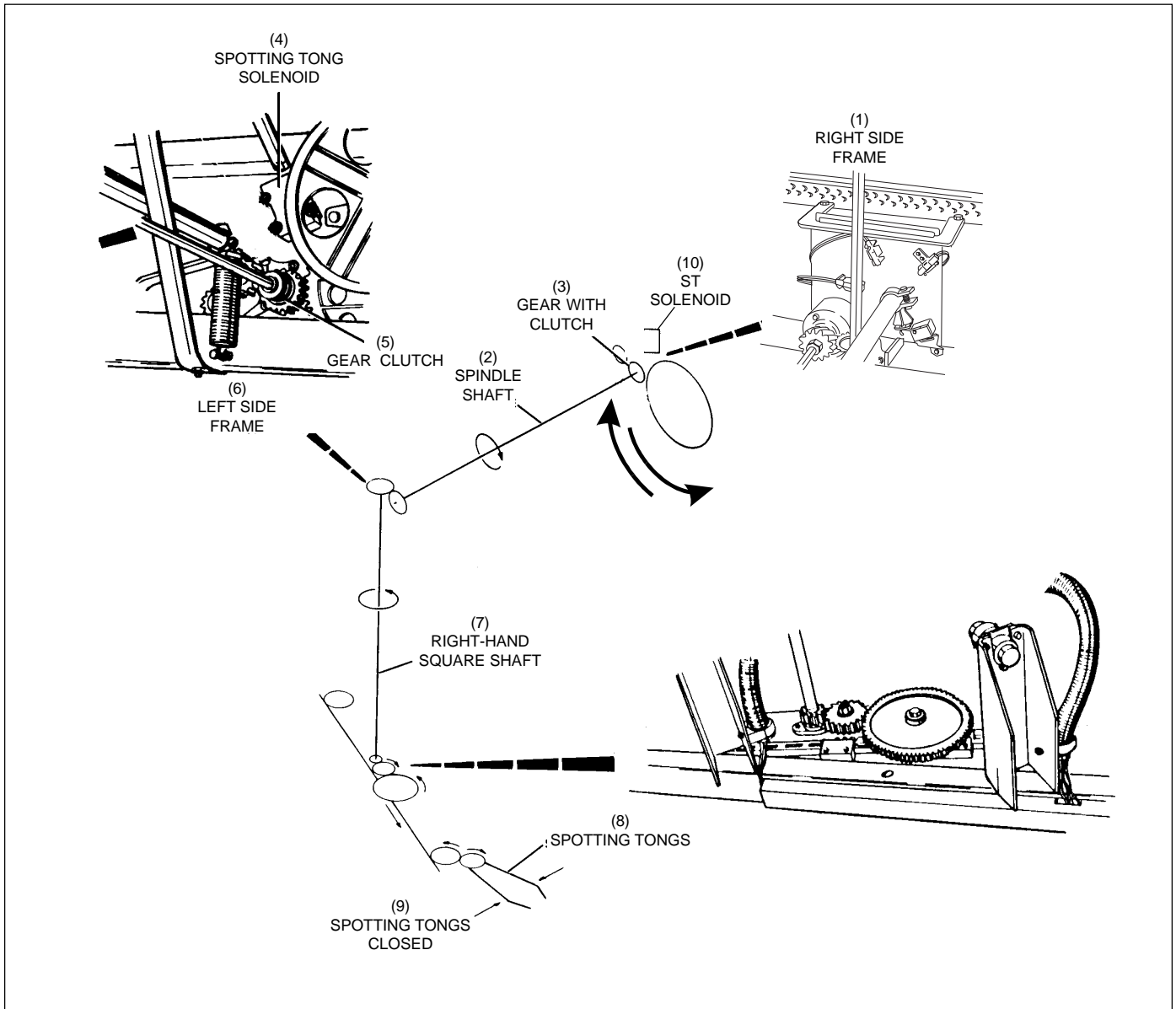

Figure 2-17. Spotting Tong Drive.

- | | | |
|-----------------------------|--------------------|---------------------------|
| (1) RIGHT SIDE FRAME | (2) SPINDLE SHAFT | (3) GEAR WITH CLUTCH |
| (4) SPOTTING TONG SOLENOID | (5) GEAR CLUTCH | (6) LEFT SIDE FRAME |
| (7) RIGHT-HAND SQUARE SHAFT | (8) SPOTTING TONGS | (9) SPOTTING TONGS CLOSED |
| (10) ST SOLENOID | | |

Pin Holder Solenoids

The red solenoid on the pin holder energizes to open the grippers. When the table is on its way up to the home position, the grippers can open to load the pins. When the table is down, the grippers open to release a new set of pins onto the pin deck.

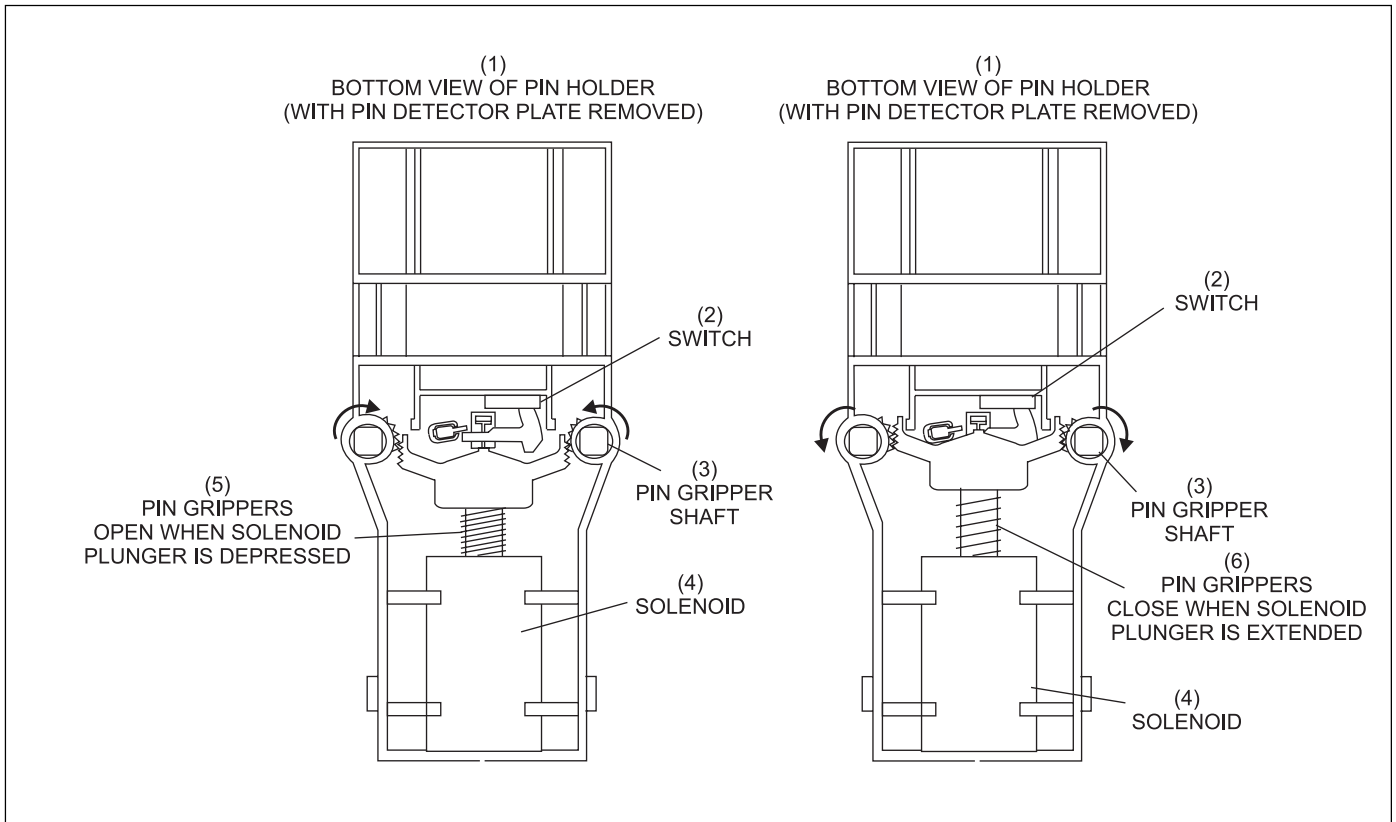

Figure 2-18. Pin Holder Horizontal - Up for Loading Pins.

- | | | |
|--|---|--|
| (1) BOTTOM VIEW OF PIN HOLDER
(WITH PIN DETECTOR PLATE REMOVED) | (2) SWITCH | (3) PIN GRIPPER SHAFT |
| (4) SOLENOID | (5) PIN GRIPPERS OPEN WHEN
SOLENOID PLUNGER IS DEPRESSED | (6) PIN GRIPPERS CLOSE WHEN
SOLENOID PLUNGER IS
EXTENDED |

Shark Solenoid

This solenoid is used to control the Shark Fin guide. Energizing the solenoid will cause the pin guide to flip left to direct the pin onto the right side of the distributor. When the solenoid is deenergized, a return spring pulls the pin guide back and deflects the pin to the left distributor lanes. The pins are loaded in a (R-L-L-R-L-R-L-L-R-L) configuration. The “R” designation is for the 10 pin or right hand side of the pinsetter. The “L” designation is for the “7” pin or the left side of the pinsetter. The electronics determined when to energize the solenoid based on the signal coming from the pin count switch.

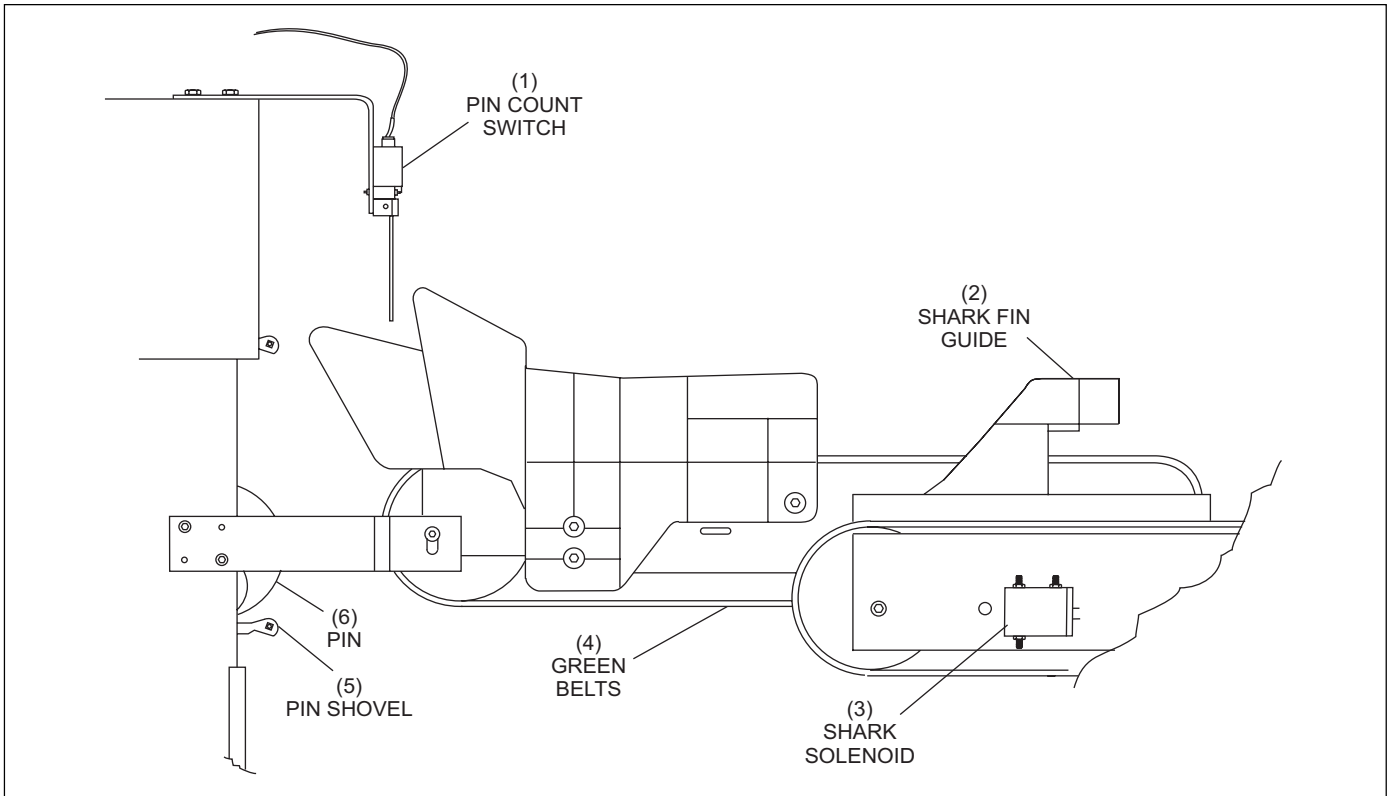

Figure 2-19. Shark Solenoid

(1) PIN COUNT SWITCH
(4) GREEN BELTS

(2) SHARK FIN GUIDE
(5) PIN SHOVEL

(3) SHARK SOLENOID
(6) PIN

Motors

All motors used on the GS Certified Pre-Owned Pinsetters are three phase motors capable of working at 208VAC, 230VAC, or 380VAC and with either 50 or 60 hertz. For proper wiring and pulley installation information when replacing a motor, see the “Service” section of this manual.

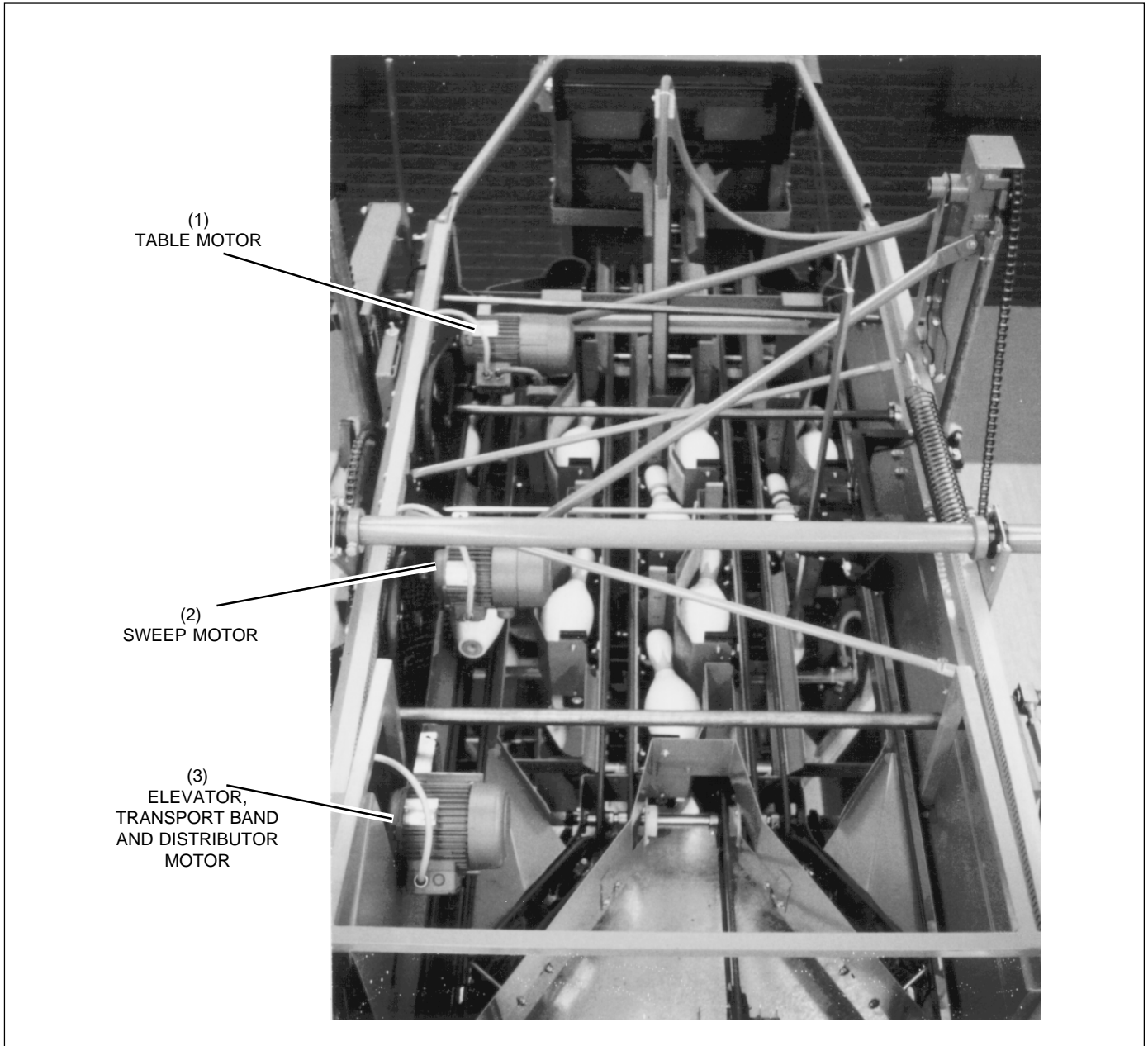

Figure 2-20. Pinsetter Motors.

(1)
BAND
MOTOR

TABLE MOTOR (2)

SWEEP MOTOR (3) ELEVATOR, TRANSPORT
AND DISTRIBUTOR

Distributor Motor

The distributor motor is a 1/2 horsepower (hp) motor located at the front left corner of the pinsetter. It drives the pin handling round belts of the distributor, the shovels in the elevator and the transport band in the pit area. This motor runs for 45 seconds to handle pins. If no ball detect or reset occurs within that time frame, it will stop and wait until a ball is detected. If the table is waiting for pins, the motor will run up to 90 seconds. If the pins are not received in that time, the machine stops with a pin load error. Refer to *Figure 2-20*.

Sweep Motor

The sweep motor is a 1/4 hp motor located at the center left-hand side of the pinsetter. It drives the sweep rearward and forward to clear pins off the pin deck. This motor has an internal brake that prevents coasting when power is turned off to the motor. Refer to *Figure 2-20*.

Table Motor

The table motor is a 1/2 hp motor at the rear left-hand side of the pinsetter. Its functions are to raise and lower the table, close and open the spotting tongs and raise the sweep at the end of a cycle. This motor runs both clockwise and counterclockwise to operate the tongs and raise the sweep when appropriate. This motor has an internal brake that locks onto the shaft when the motor is turned off. The brake holds the table up in the raised position. Refer to *Figure 2-20*.

Ball Accelerator Motor

The ball accelerator motor is incorporated into the rear accelerator drum. It runs continuously at full speed when either one or both pinsetters is in operation.