Contents

Section 3: Nexgen Electronics	3-3
General Information	3-3
Nexgen Controller Box	3-5
Left Side	3-5
Right Side	3-7
GS-Series Pinsetter Electrical Start-Up	3-9
Bottom	3-10
Top	3-10
Internal	3-11
I/O PCBs	3-12
CPU PCB	3-13
High Voltage PCB	3-16
Machine Setup	3-18
LCD Display/User Interface	3-18
Diagnostic Modes	3-22
Trouble Diagnostics	3-22
Contact Closure Diagnostics (Switch Diagnostics)	3-22
Machine Cycle Diagnostics	3-23
Using the Diagnostics	3-23
Contact Closure Diagnostics (Switch Diagnostics)	3-23
Machine Cycle Diagnostics	3-24
Related Electronics	3-27
Ball Detect - Photocell Triggering	3-27
Foul Detect	3-28
Reset Button	3-28

Intentionally Blank Page

Section 3: Nexgen Electronics

General Information

The Nexgen electronic system consists of one control box mounted on the front of the left pinsetter and several other items that monitor and help the pinsetter operate. *Figure 3-1.*

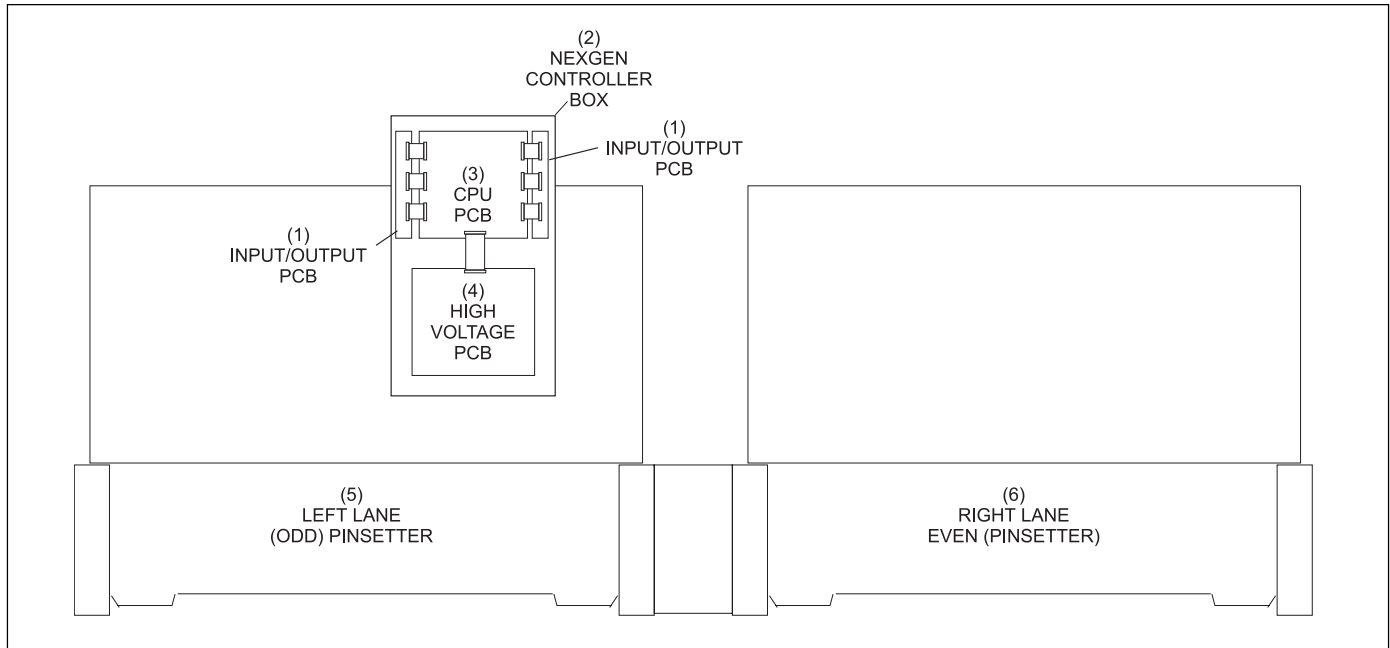

Figure 3-1. Nexgen Controller Box Layout.

- | | | |
|------------------------|-------------------------------|---------------------------------|
| (1) INPUT / OUTPUT PCB | (2) NEXGEN CONTROLLER BOX | (3) CPU PCB |
| (4) HIGH VOLTAGE PCB | (5) LEFT LANE (ODD) PINSETTER | (6) RIGHT LANE (EVEN) PINSETTER |

The CPU Board gathers switch information and sends out solenoid voltage to each pinsetter through the I/O PCBs. Communication to the scoring system is also handled by the CPU.

The High Voltage board is the entry point for the 3-phase power needed to run the pinsetters. The High Voltage board supplies the power for the motors and pin lights for both pinsetters.

Figure 3-2 is a block diagram which shows the flow of information and power paths between the pinsetters, several external devices and the electronic boxes.

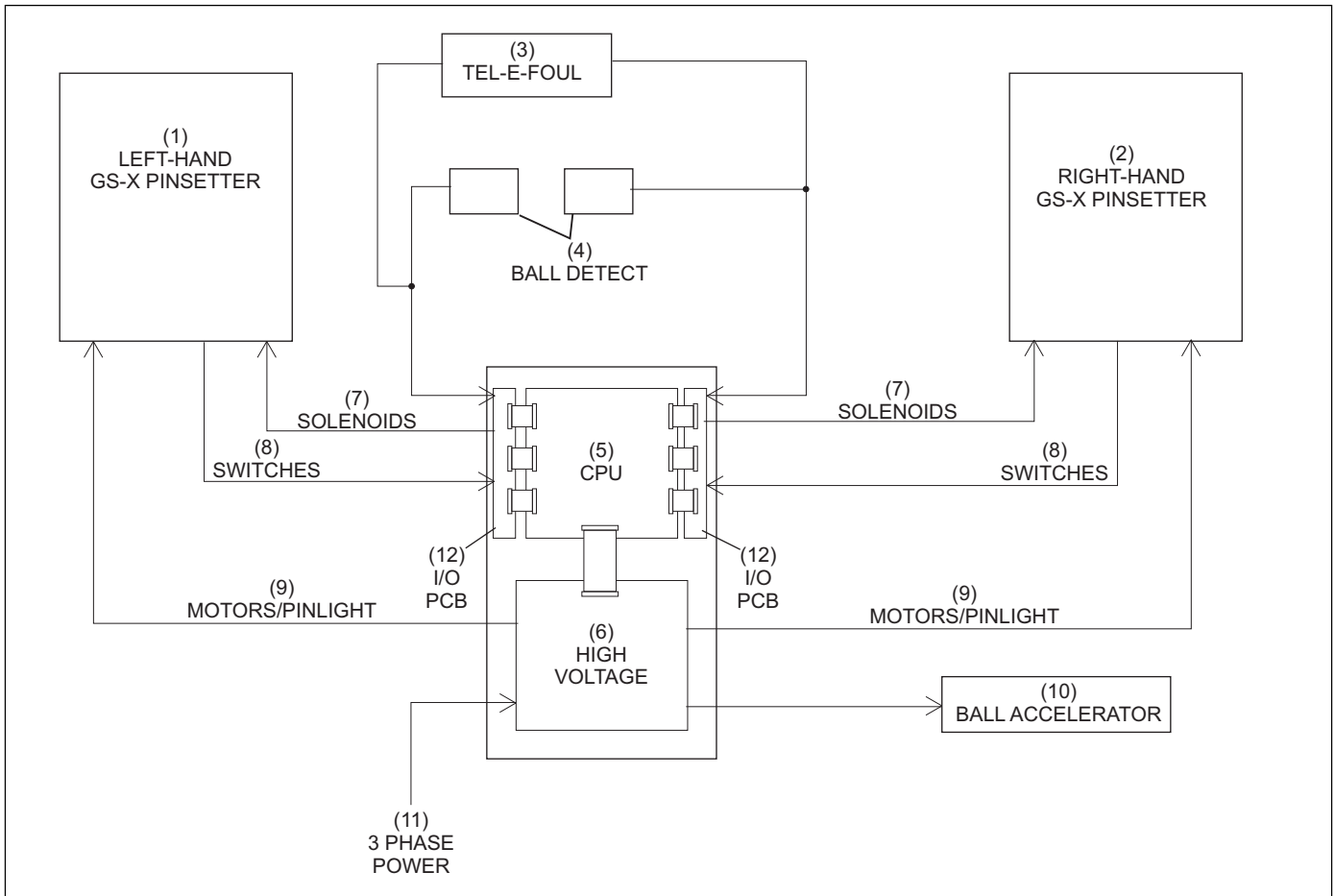

Figure 3-2. Pinsetter Block Diagram

- | | | |
|-------------------------------|---------------------------------|-----------------------|
| (1) LEFT -HAND GS-X PINSETTER | (2) RIGHT -HAND GS-X PINSETTER | (3) TEL-E-FOUL |
| (4) BALL DETECT | (5) CENTRAL PROCESSING UNIT PCB | (6) HIGH VOLTAGE PCB |
| (7) SOLENOIDS | (8) SWITCHES | (9) MOTORS / PINLIGHT |
| (10) BALL ACCELERATOR | (11) 3 PHASE POWER | (12) INPUT/OUTPUT PCB |

Nexgen Controller Box

The Nexgen Controller box receives incoming 3-phase power and makes it available to all motors, the pin lights and the transformer used to power the CPU PCB. It also receives incoming switch information and controls the solenoids for both machines. The following is a description of the boxes' components and connections. Refer to Figures 3-3, 3-4, and 3-5.

Left Side

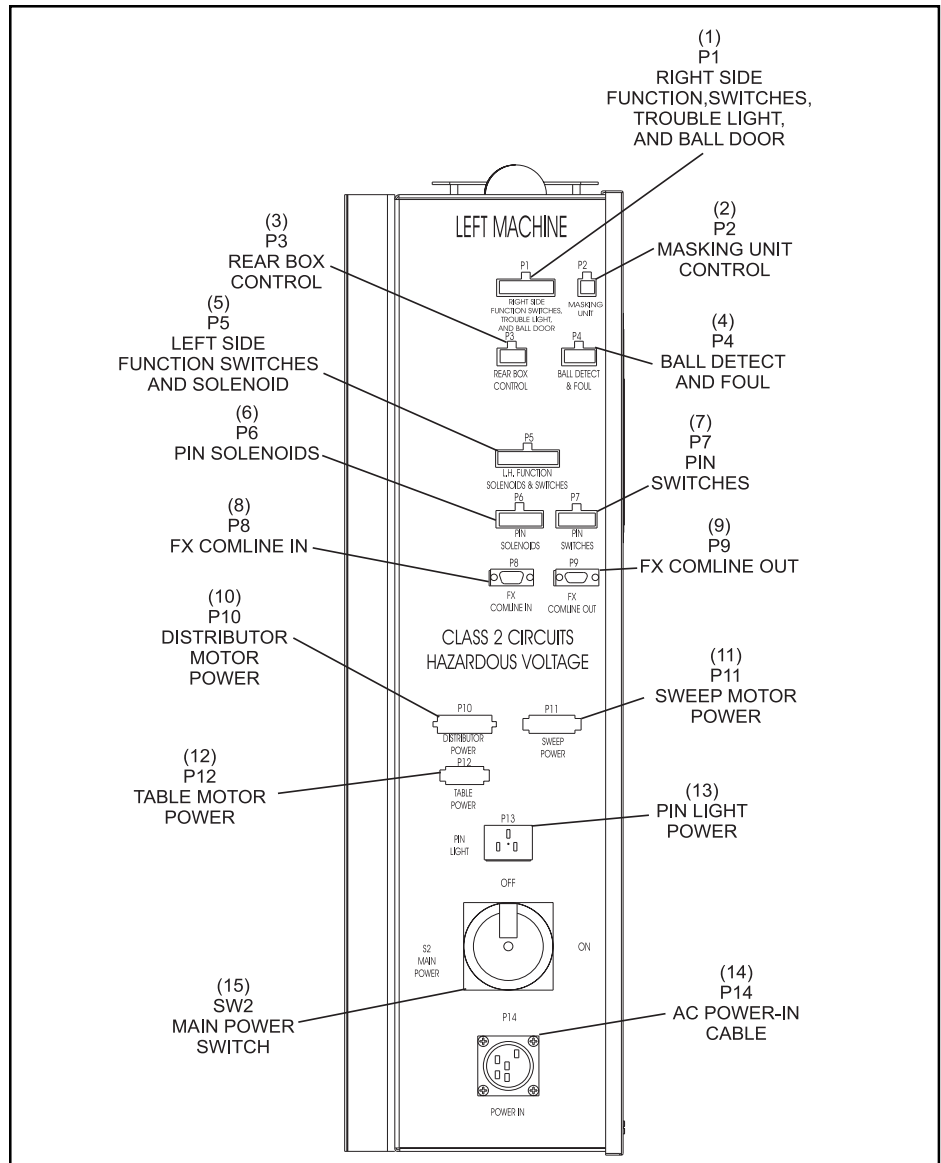

Figure 3-3. Nexgen Controller - Left Side View

- (1) **P1 (Right Side Function Switches, Trouble Light and Ball Door)** - This connection is the input for the switches located on the right side of the odd lane (left) pinsetter. These switches include the “A,” “B,” “C,” “D,” “SM,” “TS2” and “OOR.” The connection also provides the output signals for the trouble light and the ball door solenoid for the left pinsetter.

- (2) **P2 (Masking Unit Control)** - This connection provides the second ball light signal to the masking unit for the odd numbered (left) lane.
- (3) **P3 (Rear Box Control)** - This connection provides input from the set, reset, and stop/run switches mounted on the elevator of the odd lane (left) pinsetter.
- (4) **P4 (Ball Detect & Foul)** - This connection provides input from the ball detector, foul unit, and ball rack reset button for the odd (left) lane
- (5) **P5 (Left Side Function Switches and Solenoids)** - This connection provides the input for the “TS1,” “G,” “EC” and pin count switches. It provides output signals to the sweep release, spotting tong, stroke limiter, and shark solenoids of the odd lane (left) pinsetter.
- (6) **P6 (Pin Solenoids)** - The pin holder (gripper) solenoids for the left pinsetter are energized and de-energize via the voltages sent from this connector
- (7) **P7 (Pin Switches)** - This connection provides input from the pin holder switches and spotting tong (ST) switch for the left pinsetter.
- (8) **P8 (FX Comline In)** - This connection is used to connect to Brunswick Scoring Systems. It provides two-way communication between the Pinsetter CPU and the I/O PCB in Vector primary consoles or LGPs. If software version 4.08.03 or higher is installed on the CPU, this connection is also used to connect the pinsetter to AS-90 scorers (see “*Right Side*” connection - page 16)
- (9) **P9 (FX Comline Out)** - This connection is used for the Vector Scoring Systems. It routes communication signals through the Pinsetter CPU to the Vector lane devices such as TV Only monitors or Bowler Track.
- (10) **P10 (Distributor Motor Power)** - Provides 3-phase power to the odd lane (left) pinsetter's distributor motor.
- (11) **P11 (Sweep Motor Power)** - Provides 3-phase power to the odd lane (left) pinsetter's sweep motor.
- (12) **P12 (Table Motor Power)** - Provides 3-phase power to the odd lane (left) pinsetter's table motor.
- (13) **P13 (Pin Light Power)** - Provides 208 or 230 VAC single phase to the odd lane (left) pinsetter's pin light.
- (14) **P14 (AC Power-In Cable)** - Input power connection for the 3-phase power. This voltage can be 208, 230 or 380 - 415 VAC.
- (15) **SW2 (Main Power Switch)** - Controls the 3-phase power entering the box. In the off position, this switch will disable both pinsetters and the ball accelerator.

Right Side

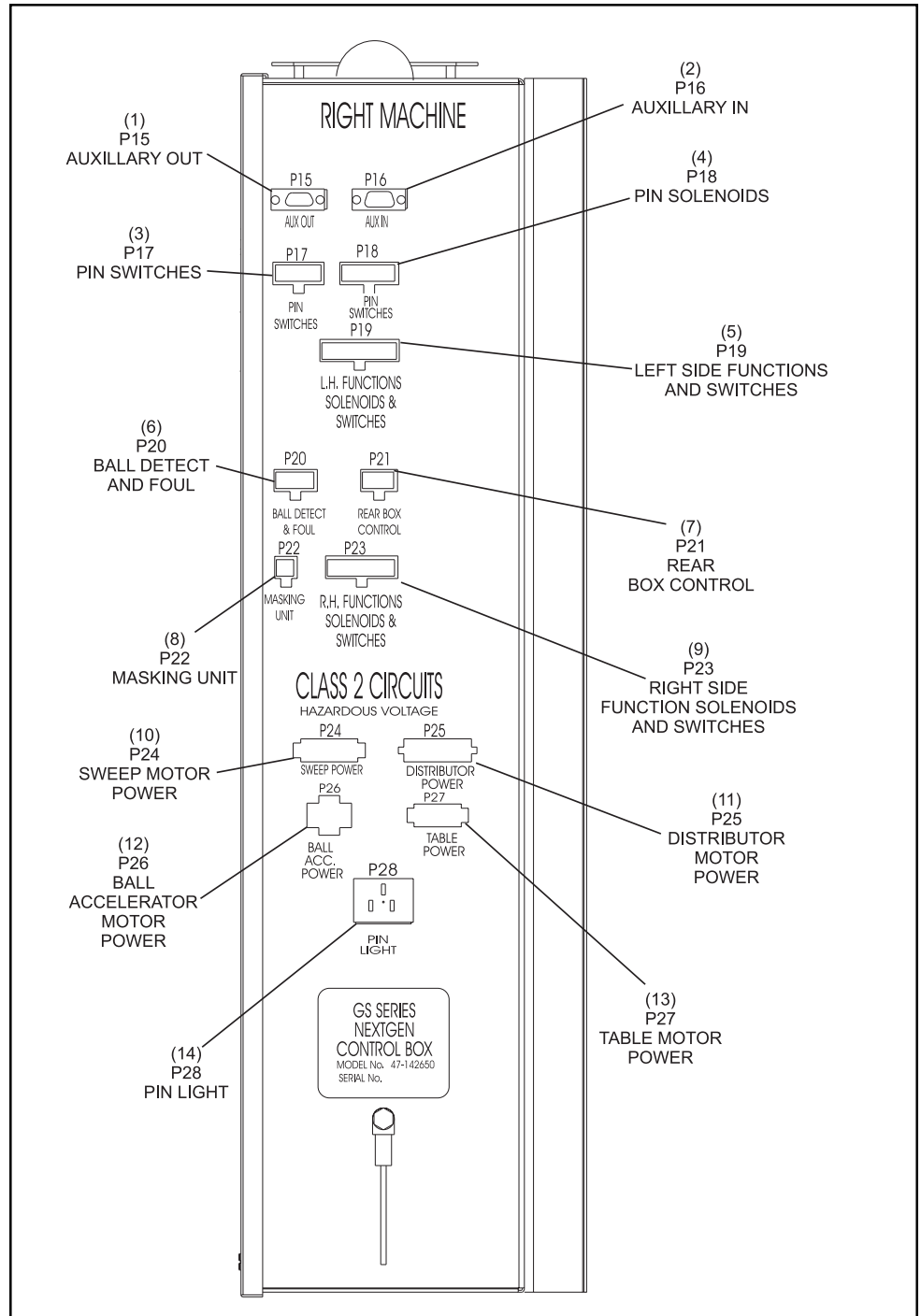

Figure 3-4 Nexgen Controller - Right Side View

- (1) **P15 (Auxiliary Out)** - Not Used
- (2) **P16 (Auxillary In)** - Not Used
- (3) **P17 (Pin Switches)** - This connection provides input from the pin holder switches and spotting tong (ST) switch for the right pinsetter.

- (4) **P18 (Pin Solenoids)** - The pin holder (gripper) solenoids for the right pinsetter are energized and de-energized via the voltage sent from this connector.
- (5) **P19 (Left Side Function Solenoids and Switches)** - This connection provides the input for the “TS1,” “G,” “EC” and pin count switches. It provides output signals to the sweep release, spotting tong, stroke limiter and shark for the even lane pinsetter.
- (6) **P20 (Ball Detect & Foul)** - This connection provides input from the ball detector, foul unit, and ball rack reset button for the even lane
- (7) **P21 (Rear Box Control)** - This connection provides input from the set, reset, and on/off switches mounted on the elevator of the even lane pinsetter.
- (8) **P22 (Masking Unit)** - This connection provides the second ball signal to the masking unit for the even lane.
- (9) **P23 (Right Side Function Solenoids and Switches,)** - This connection is the input for all the switches on the right hand side of the even lane pinsetter. These switches are “A,” “B,” “C,” “D,” “SM,” “TS2” and “OOR.” The connection also provides the output signals for the trouble light and the ball door solenoid for the even lane pinsetter.
- (10) **P24 (Sweep Motor Power)** - Provides full 3-phase power to the even lane pinsetter's sweep motor.
- (11) **P25 (Distributor Motor Power)** - Provides 3-phase power to the even lane pinsetter's distributor motor.
- (12) **P26 (Ball Accelerator Motor Power)** - Provides 3-phase power to the ball accelerator motor.
- (13) **P27 (Table Motor Power)** - Provides 3-phase power to the even lane pinsetter's table motor.
- (14) **P28 (Pin Light)** - Provides 208 or 230 VAC single phase to the even lane pinsetter's pin light.

GS-Series Pinsetter Electrical Start-Up

1. The transformers connections to the High Voltage PCB depends on the operating voltage of the pinsetter. Reference *Figure 3-5* & *Table 1*.

- (1) TRANSFORMER PRIMARY TAP 1
- (2) TRANSFORMER PRIMARY TAP 2
- (3) UNUSED TRANSFORMER TAPS

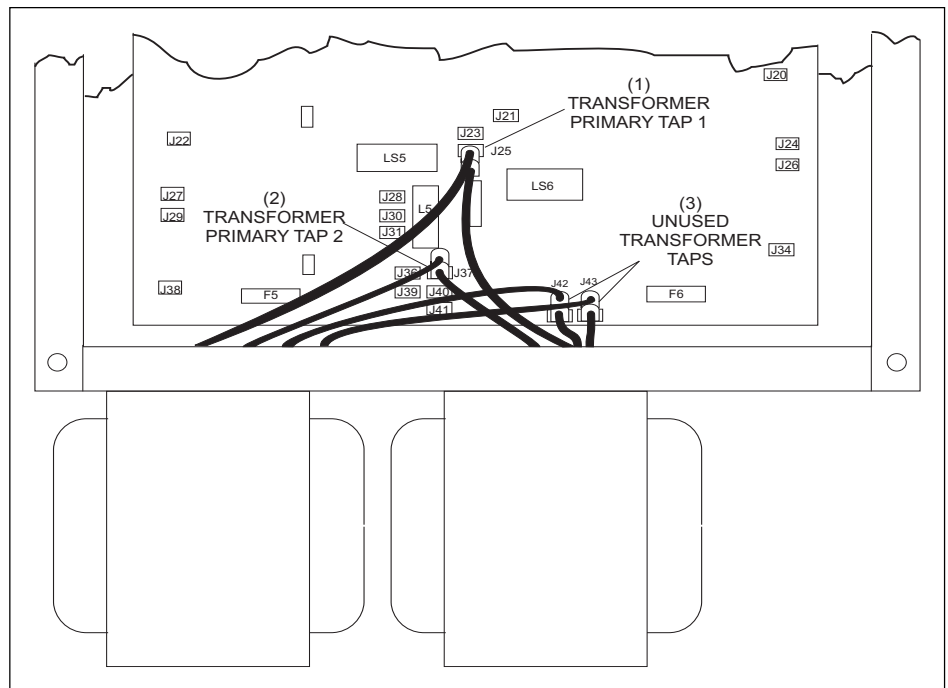

Figure 3-5. Nexgen Voltage Settings

TRANSFORMER 1			
Input Voltage	Wire	Transformer Tap	High Voltage PCB Terminal
220V 380V 415V	BLK	Common	J37
	BLK/RED	230V	J25
	BLK/WHT	Not Used	Not Used
	BLK/YEL	Not Used	J42
208V	BLK	Common	J37
	BLK/YEL	208V	J25
	BLK/RED	Not Used	J42
	BLK/WHT	Not Used	Not Used
200V	BLK	Common	J37
	BLK/WHT	200V	J25
	BLK/YEL	Not Used	J42
	BLK/RED	Not Used	Not Used

TRANSFORMER 2			
Input Voltage	Wire	Transformer Tap	High Voltage PCB Terminal
220V 380V 415V	BLK	Common	J37
	BLK/RED	230V	J25
	BLK/WHT	Not Used	Not Used
	BLK/YEL	Not Used	J43
208V	BLK	Common	J37
	BLK/YEL	208V	J25
	BLK/RED	Not Used	J43
	BLK/WHT	Not Used	Not Used
200V	BLK	Common	J37
	BLK/WHT	200V	J25
	BLK/YEL	Not Used	J43
	BLK/RED	Not Used	Not Used

Table 1. Transformer Taps

Bottom

Mounted on the bottom of the Nexgen box are two transformers. The transformers use an incoming 230 Volt or 208 Voltage from the High Voltage PCB and reduces it to 26VAC. This voltage is then sent to the CPU PCB (J11) where it is used to create the DC voltages for pinsetter operation.

Top

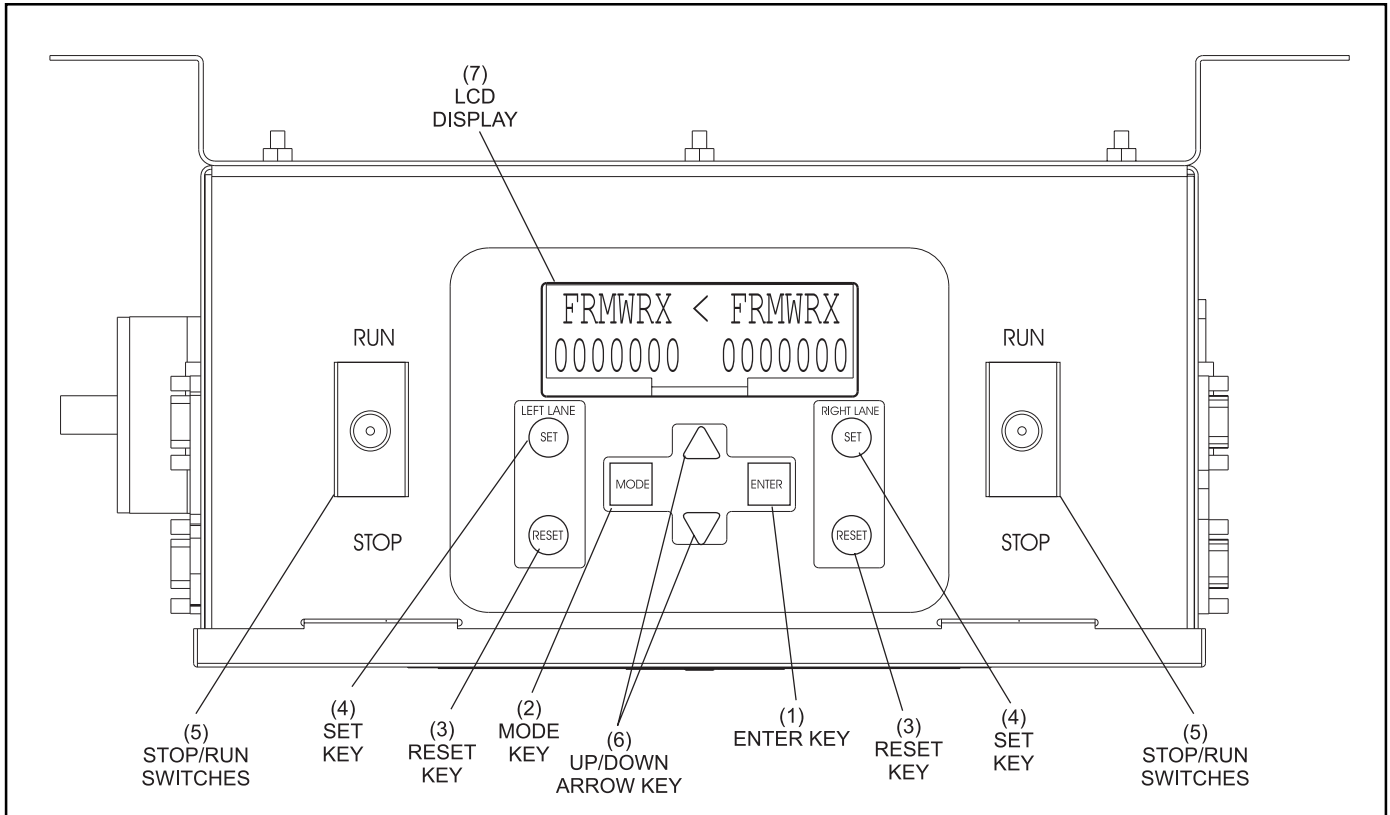

Figure 3-6. Nexgen Controller - Top View

- (1) **Enter Key** - This push button key has two functions. During pinsetter setup it is used to select the left or right lane. Once a configuration mode has been selected using the Mode key, it is used to display the different options available for the mode.
- (2) **Mode Key** - This push button key allows the mechanic to select the different pinsetter setup modes used to configure how the machine should operate.
- (3) **Reset Keys** - These push button keys cause the pinsetter to cycle to the next ball. Push button switches with the same function are mounted on the ball rack for the bowler's use and on the rear control box located on the elevator for the mechanics' use .

- (4) **Set Keys** - These push button keys causes the last combination of pins to be set. Push button switches with the same function are located on the rear control box mounted on the elevator.
- (5) **Stop/Run Switches** - This toggle switch is used to manually stop or start the pinsetter. Turning this switch to the Stop position will de-energize the lane power relays on the High Voltage PCB for the pinsetter.
- (6) **Up/Down Arrow Keys** - These push button keys allow the mechanic to setup the option being displayed.
- (7) **LCD Display** - This display shows the frame count, error codes and setup information for both pinsetters.

Internal

Internally, the Nexgen Controller box contains four circuit boards; a CPU PCB, a High Voltage PCB and two I/O PCBs. Refer to *Figure 3-7*

- (1) INPUT / OUTPUT PCB
- (2) NEXGEN CONTROLLER BOX
- (3) CPU PCB
- (4) HIGH VOLTAGE PCB

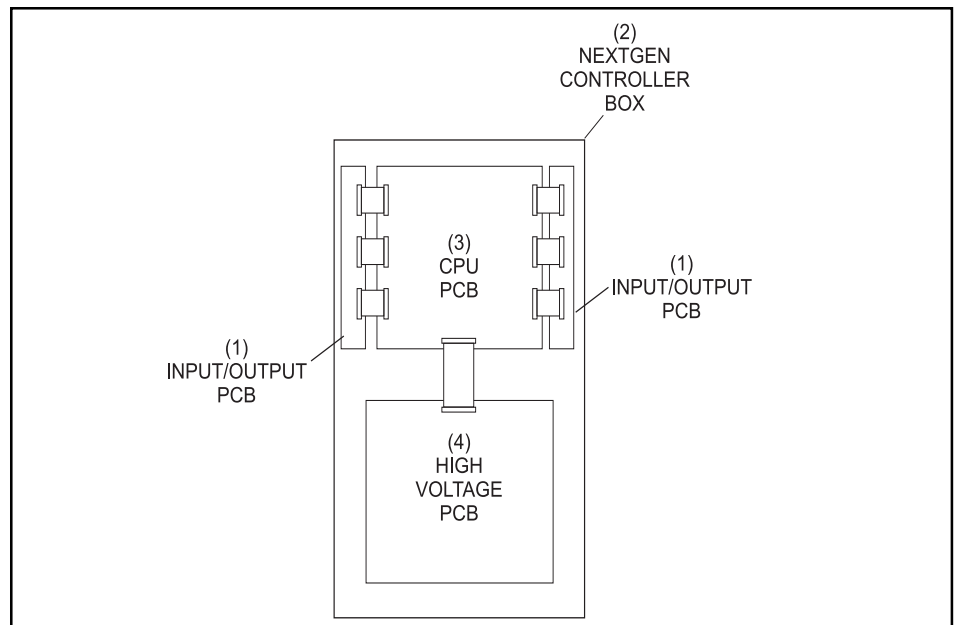

Figure 3-7. Nexgen Controller - Internal View

I/O PCBs

I/O is an acronym for input and output. These printed circuit boards receive the incoming information from the pinsetter and pass it on to the CPU. The CPU then makes an appropriate decision and sends its commands back to the pinsetter through the I/O printed circuit board. Refer to *Figure 3-8*.

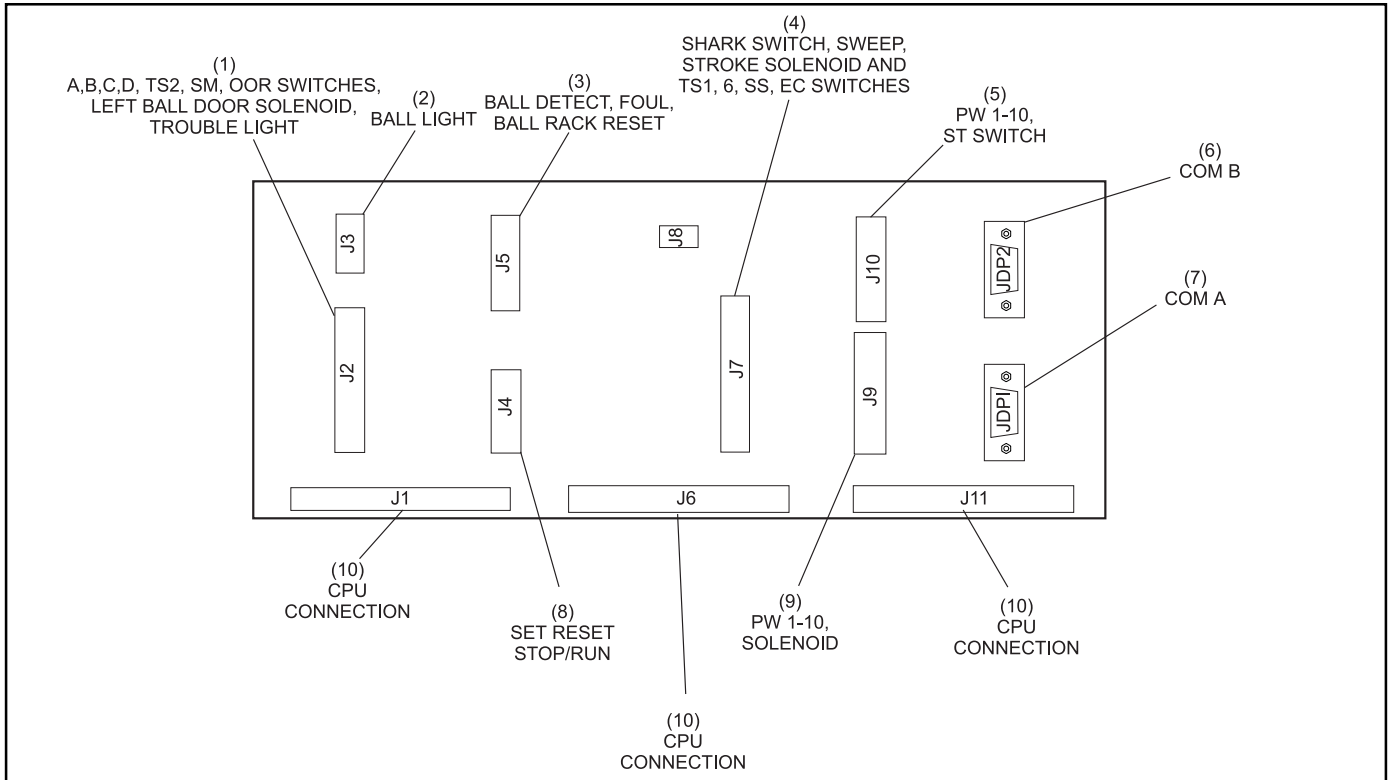

Figure 3-8. I/O PCB

- | | | |
|--|-------------------------|--|
| (1) A,B,C,D, TS2, SM, OOR SWITCHES, LEFT BALL DOOR SOLENOID, TROUBLE LIGHT | (2) BALL LIGHT | (3) BALL DETECT, FOUL, BALL RACK RESET |
| (4) SHARK SWITCH, SWEEP, STROKE SOLENOID, AND TS1, 6, SS, EC SWITCHES | (5) PW 1-10 ST SWITCHES | (6) COM B |
| (7) COM A | (8) SET RESET, STOP/RUN | (9) PW 1-10 SOLENOID |
| (10) CPU CONNECTION | | |

CPU PCB

CPU is an acronym for Central Processing Unit. This board accepts all the information from both I/O PCBs, and processes it to determine what each pinsetter must do. It then controls the pinsetter solenoids through the I/O PCBs and motors through the High Voltage PCB.

The CPU has a memory that retains the status and frame count of each pinsetter. Refer to *Figures 3-9 & 3-11*.

The function of the components and connectors on the CPU PCB are as follows:

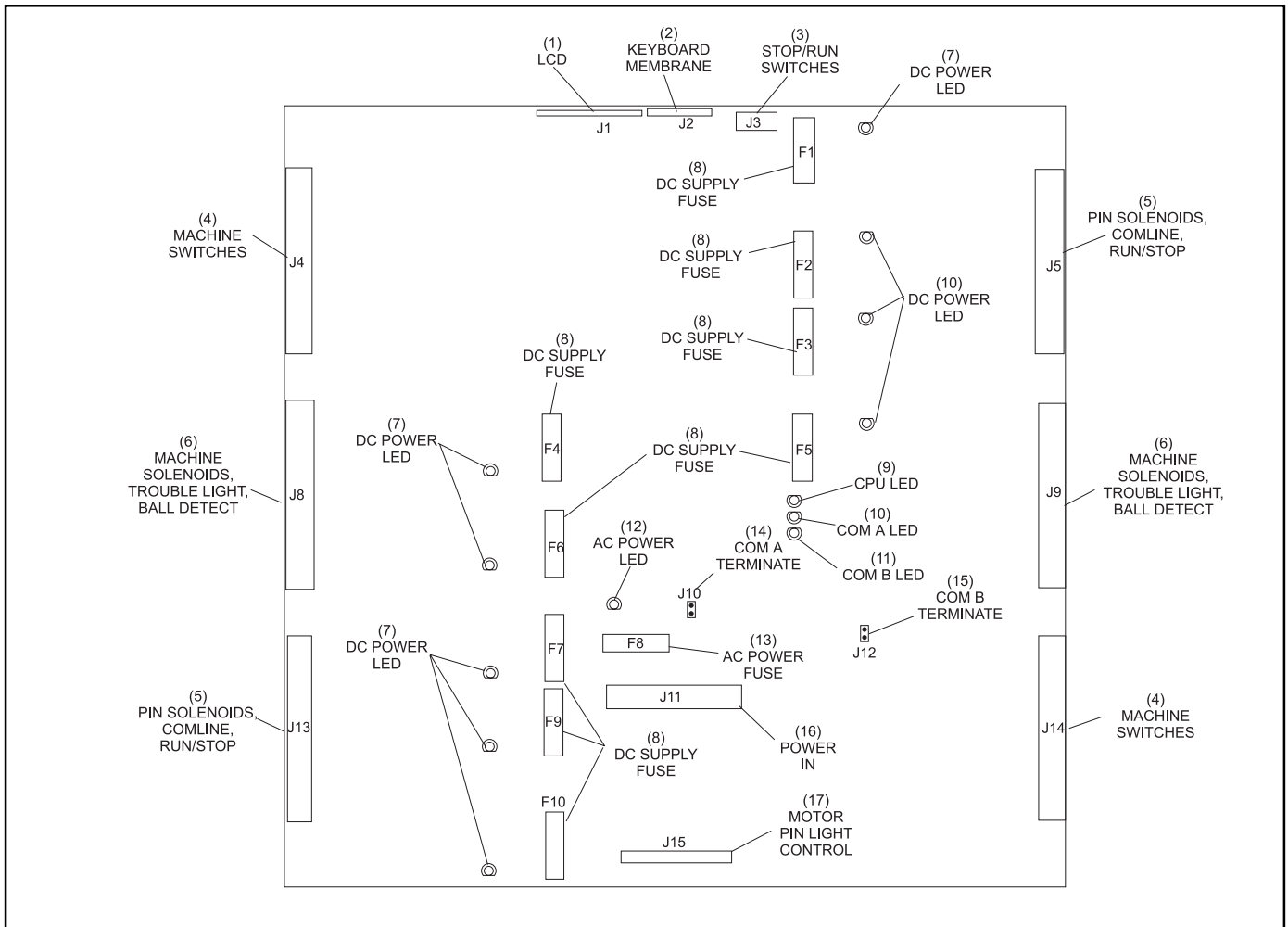

Figure 3-9. CPU PCB.

NOTE: All fuses are rated at 250V 3.15A - fast blow.

- (1) **LCD (J1)** - Connection to the LCD Panel located at the top of the Nexgen box.
- (2) **Keyboard Membrane (J2)** - Connection to the Keyboard for the LCD panel located at the top of the Nexgen box.

- (3) **Stop/Run Switches (J3)** - Connection to the stop/run switches at the top of the Nexgen box.
- (4) **Machine Switches (J4, J14)** - Input connection for the following machine signals: TS1 ,G, pin count, EC, A, B, C, D, TS2, SM, ST and OOR switches, all 10 pin holders switches, rear control box set and reset switches, ball rack reset switch, foul unit, and ball detector. J4 connects to the left pinsetter while J14 is for the right pinsetter.
- (5) **Pin Solenoid,Comline,Stop/Run (J5, J13)** - This connection supplies voltage to the pinholder solenoids and ball lift and is the connection for the Stop/Run Switch located on the elevator. The communication to the Vector scorer system is also handled by this connection. J5 connects to the right pinsetter and J13 connects to the left pinsetter.
- (6) **Machine Solenoids,Trouble Light,Ball Detect (J8 ,J9)** - Connection that supplies voltage to the spotting tong, sweep release, shark, and ball door solenoids and the trouble lights. This connection is also provides input for the ball detectors. J8 is for the left pinsetter and J9 is for the right pinsetter.
- (7) **DC Power LEDs** - These LEDs light when the DC voltage for the 26 Volt circuitry is operating.
- (8) **DC Power Fuses (F1-F7, F9, F10)** - Fuses used to protect the 26VDC circuitry. These fuses are rated at 250V 3.15A - fast blow.
 - F1** (RH Pinsetter) **F10** (LH Pinsetter) - 1,2,3 Pin Gripper Solenoids, Spotting Tong Solenoid
 - F2** (RH Pinsetter) **F9** (LH Pinsetter) - 4,5,6 Pin Gripper Solenoids, Sweep Release Solenoid
 - F3** (RH Pinsetter) **F7** (LH Pinsetter) - 7,8,9 Pin Gripper Solenoids, Stroke Limiter Solenoid
 - F4** - left Ball Detect, right Ball Detect, left Trouble Light, and right Trouble Light
 - F5** (RH Pinsetter) **F6** (LH Pinsetter) - 10 Pin Gripper Solenoids Shark Solenoid, and Ball Door Solenoid
- (9) **CPU LED** - Labeled “CPU” this LED lights when the microprocessor is operating properly.
- (10) **Com A LED** - Labeled “Com A” this LED lights when communication to the Framework scorers is functioning properly.

- (11) **Com B LED** - Labeled Com “B” - not used.
- (12) **AC Power LED** - This LED lights when the AC input voltage to the CPU is present.
- (13) **AC Power Fuse (F8)** - Fuse used to protect the CPU from excessive AC input power. This fuse are rated at 250V 3.15A - fast blow.
- (14) **Com A Termination (J10)** - Com A termination jumper.
- (15) **Com B Termination (J12)** - Com B termination jumper.
- (16) **Power In (J11)** - 26VAC Power in from the main transformer.
- (17) **Motor, Pin Light Control (J15)** - Connection to the High Voltage PCB used to control the motor and pin light operation for both pinsetters .

High Voltage PCB

The High Voltage board is the entry point for the 3-phase power needed to run the pinsetters. The High Voltage board uses this power to control the motors and pin lights for both pinsetters. Fuses on the PCB are used to protect the motors and pin lights. Refer to *Figure 3-10*.

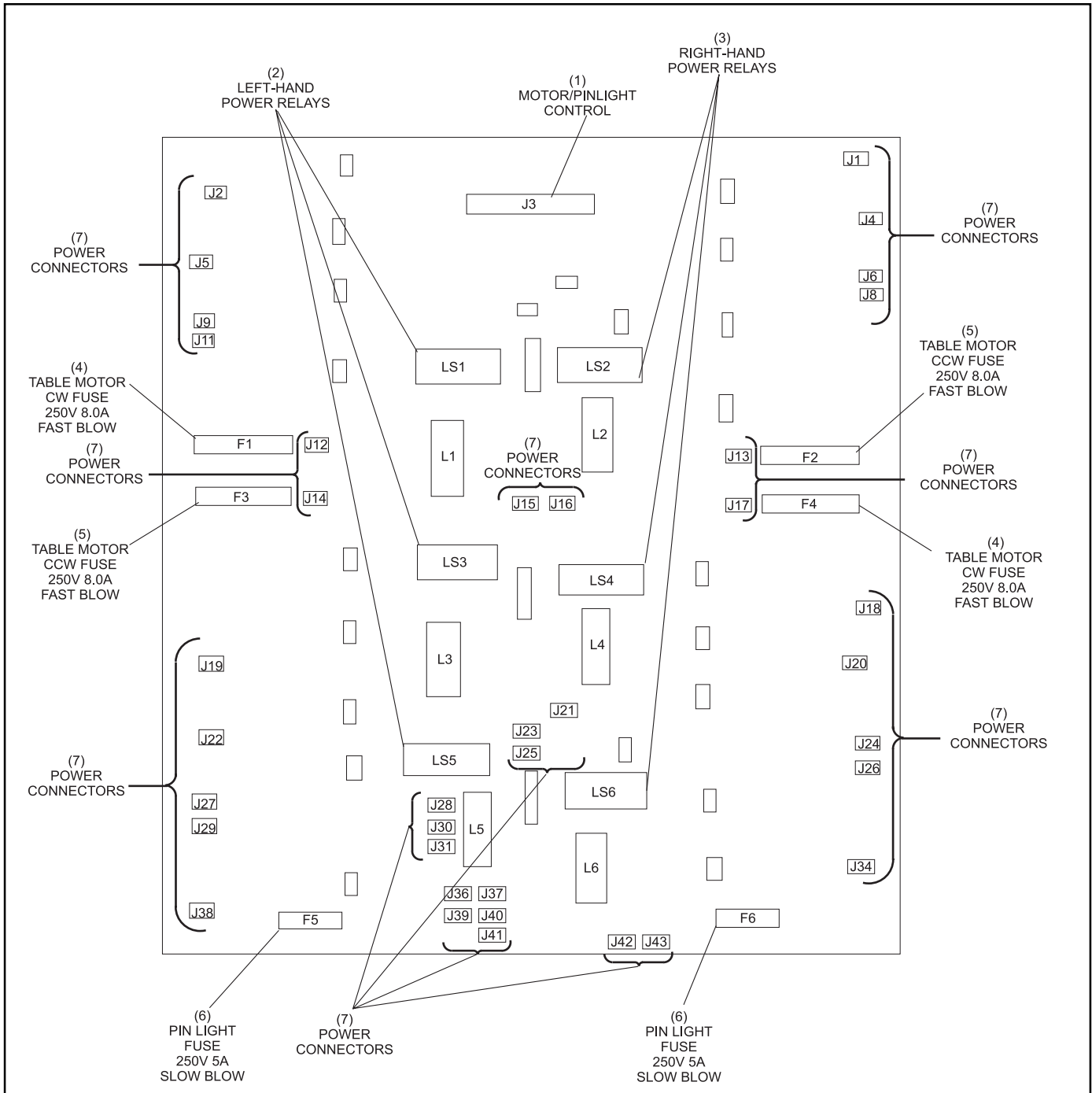

Figure 3-10. Nexgen Controller - High Voltage PCB

The function of the component on the High Voltage PCB are:

- (1) **Motor/Pinlight Control (J3)** - Connection for the cable originating at the CPU PCB. The High Voltage is “told” when to turn the motors and pinlights ON/Off through this connection.

- (2) **Left Hand Power Relays** - Main power relays for each phase of power entering the Nexgen box. When energized power is made available to the left pinsetter's motor and pin light circuitry.
- (3) **Right Hand Power Relays** - Main power relays for each phase of power entering the Nexgen box. When energized power is made available to the right pinsetter's motor and pin light circuitry.
- (4) **Table Motor CW Fuse(F1,F4)** - Fuses used to protect the table motor circuitry from excessive current when turning the table motor on in a clockwise rotation. F1 is for the left pinsetter, F4 is for the right pinsetter. The fuses are rated at 250V 8.0A - fast blow.
- (5) **Table Motor CCW Fuse(F2,F3)** - Fuse used to protect the table motor circuitry from excessive current when turning the table motor on in a counterclockwise rotation. F3 is for the left pinsetter, F2 is for the right pinsetter. The fuses are rated at 250V 8.0A - fast blow.
- (6) **Pin Light Fuses (F5,F6)** - Fuses used to protect the pin lights from excessive current. F5 is for the left pinsetter, F6 is for the right pinsetter. The fuses are rated at 250V 5A - slow blow.
- (7) **Power Connectors** - Connections to pinsetter motors and pinlight.

Machine Setup

LCD Display/User Interface

Setup and diagnostics for the both pinsetters is performed using the Nexgen LCD Panel. Refer to *Figure 3-12*.

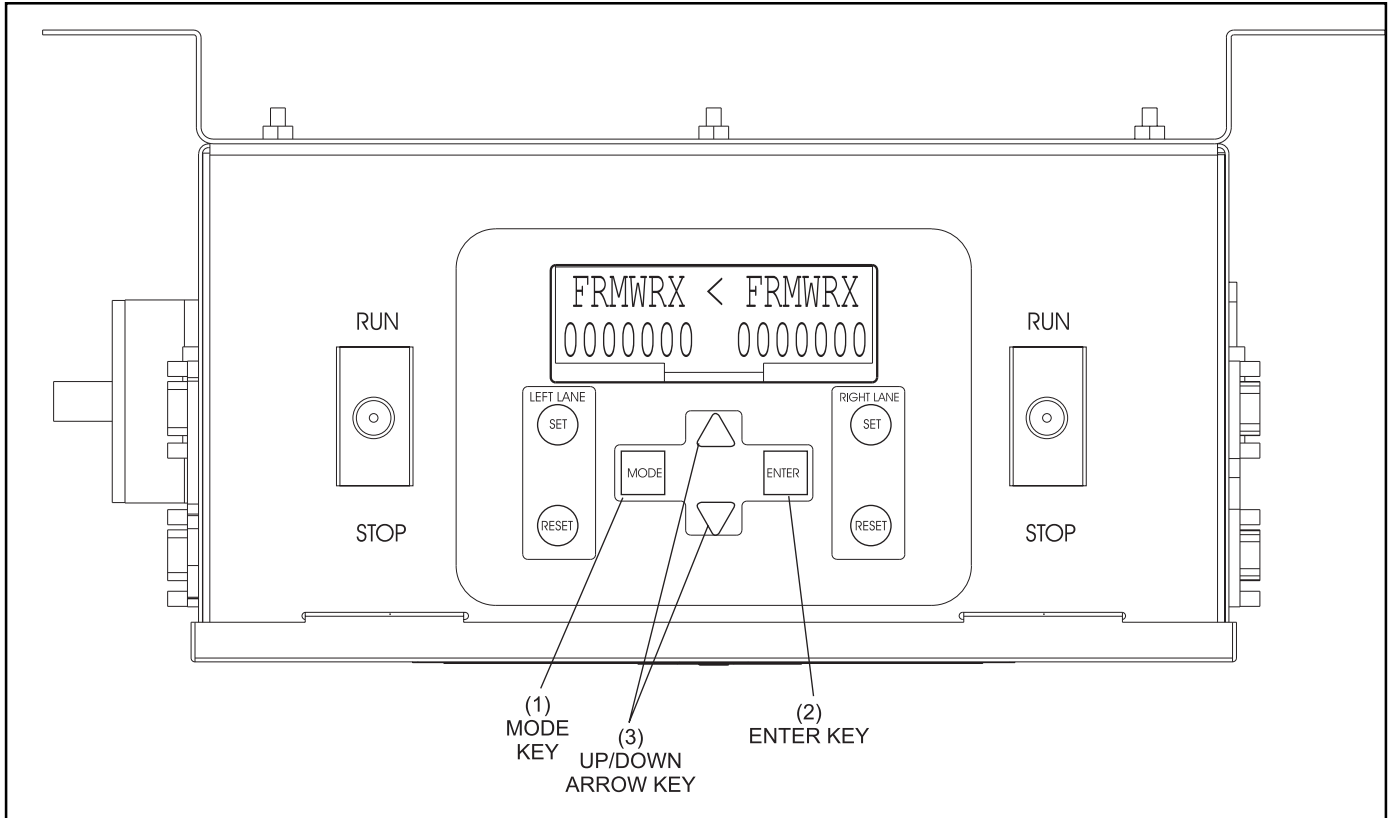

Figure 3-11. Nexgen Controller - LCD Panel

Four keys on the control panel are used to navigate the user menu.

- (1) **Mode Key** - Use this button to step through the pinsetter modes when the mode selection menu is being displayed or to return to the mode selection menu.
- (2) **Enter Key** - The function of this key is dependent on what is being displayed on the LCD. If the mode displayed on the LCD does not have a submenu, this key allow the user to select the left or right lane. When the mode displayed on the LCD has a submenu, the Enter key steps through the submenu selections.
- (3) **Up/Down Arrows** - The function of this key is dependent on what is displayed on the LCD. When the mode selection menu is displayed, this key allows the user to step through the pinsetters modes. When in a submenu, the arrow keys allow the user to toggle the choices of the feature selected in the submenu.

During power up of the Nexgen Controller, the unit it goes through a boot up sequence. The Controller's LCD display will first display "Brunswick GS-X" and then display "Software V 4.08 / EPROM OK". Once the controller successfully boots up, the mode selection menu is displayed.

The Mode selection menu has the following choices:

- Frmwrx -** Use this setting when the GS Certified Pre-owned pinsetter is connected to Framework and/or Vector scoring systems. This selection does not have a submenu.
- Tenpin -** Use this setting when the GS Certified Pre-owned pinsetter is NOT connected to a scoring system or is operating in a stand-alone mode. This selection does not have a submenu.
- AS-90 -** This setting appears only if software version 4.08.03 or higher is installed in the Nexgen box. Use this setting when a GS Certified Pre-owned is connected to an AS-80, or AS-90 scorer. This selection does not have a submenu
- Diag -** This selection allows the mechanic to put the selected pinsetter into cycle diagnostics mode. This selection does not have a submenu.
- Motor -** This selection allows the mechanic to manually run the pinsetter motors on the selected machine. A submenu that appears when the stop/run switch is set to the run position has the following choices:
 - Table CW -** This selection turns the table motor of the selected lane in a clockwise rotation.
 - Table CCW -** This selection turns the table motor of the selected lane in a counterclockwise rotation.
 - Distrib -** This selection turns the distributor motor of the selected lane on.
 - Sweep -** This selection turns the sweep motor of the selected lane on.
- Pinlight -** This selection caused the pinlight of the selected pinsetter to turn on.

NOTE: The following selections are available only when the STOP/RUN switches for both pinsetters are in the STOP position.

Setup - This selection allows the user to configure the pinsetter's operating characteristic. A submenu for this selection has the following choices:

NOTE: Use the enter button to select the desired choice and the arrow buttons to choose yes or no.

Left Lane # ## - Sets the lane ID for the lane pair. Use the arrow keys to select the left (odd) lane number for the lane pair.

Double Detect: (Y or N) - Gives the pinsetter the choice of detecting pin activity on second ball. If a scoring system is present that has the capability of interfacing with the CPU, it can use the pin holder switch information to determine the bowler's pinfall. If no scoring system is available, or the scoring system uses a scanner or camera for determining pinfall, turning this switch on disables the detection stroke of the setting table during the second ball.

Y - Double Detect - Set if a scanner or CCD Camera are not used. (Frameworkx scoring system) (default)
N - Single Detect - Set if a scanner, CCD Camera or VPS are used or if no scoring system is used.

Enable OOR: (Y or N) - Enable or disables the out-of-range cycle. ABC, the FIQ and many other bowling organizations require that the pinsetter stop and any deadwood (pins that have been knocked over but are still in the field of play) must be removed before the next ball can be rolled. In many countries, this is not a requirement and it interferes with the bowler's flow of bowling. If your center has sanctioned leagues that require deadwood be removed before a second ball is rolled, this switch should be in the left position.

Y - Pinsetter stops for an out-of-range pin. (default)
N - Ignores an out-of-range pin.

Table Delay: (Y or N) - This selection controls the delay of the setting table operation after the sweep drops to a guarded position.

Y - Delayed setting table - ABC, FIQ..., compliant delay. (default)
N - Quick setting table - No delay after sweep drop.

Distrib Stop: (Y or N) - This selection determines if the distributor will stop after all 10 pins have been delivered to the pin holders while waiting for a 2nd ball cycle. The suggested setting for this option is "N".

Y - Stop enable - Distributor stops after ten pins have loaded while waiting for a 2nd ball.
N - Stop disabled - Continuous distributor operation while loading pin. (default)

Enable 50 ERR (Y or N) - This selection allows pinfall detection to be monitored or ignored during machine cycle diagnostics.

Y - Enable Codes (default)

N - Disable Codes

Enable Foul: (Y or N) - This selection allows you to accept or ignore the foul signal coming from the foul unit.

Y - The pinsetter will accept the foul signal (default)

N - Foul Signals are ignored.

Dist Slow Start: (Y or N) - This selection is available on machines with software version 4.08.02 and higher. The selection determines whether the distributor will start slowly and gradually increase speed or start at full speed. The suggested setting for this option is "N".

Y - Slow start enabled

N - Slow start is disabled

Long Err Codes: (Y or N) - This selection is available on machines with software version 4.08.02 and higher. The selection determines whether the display will show error code using the standard 2 digit code or extended code.

Y - Display error codes using extended format

N - Display error codes using 2 digit format

Pinlight: (Y or N) - This selection is available on machines with version 4.08.02 and higher. This selection turns on the pinlight so that the pins are illuminated even when the machine is unassigned.

Y - Pinlight on

N - Pinlight off

SW Diag - This selection allows the user to check the switches on the pinsetters. The display will list the switches that are actuated (closed) are used during the time the check is being made. This mode can be used to verify that switches are working properly and the wiring. A submenu for this selection has the following choices:

Pin SW (Left) - This selection checks the pinholder switches and displays the ones that are actuated on the left pinsetter.

Table SW (Left) - This selection checks the Table switches A, B, C, D, TS1, and TS2 and displays the ones that are actuated on the left pinsetter.

Mach SW (Left) - This selection checks the machine switches EC, G, SM, OOR, ST, Pincount Switch, and displays the ones that are actuated on the left pinsetter.

EXT SW (Left) -This selection checks the external switches Ball Detect, Foul, Set And Reset and displays the ones that are actuated on the left pinsetter.

Pin SW (Right) - This selection checks the pinholder switches and displays the ones that are actuated on the left pinsetter.

Table SW (Right) - This selection checks the Table switches A, B, C , D, TS1, and TS2 and displays the ones that are actuated on the right pinsetter.

Mach SW (Right) - This selection checks the machine switches EC, G, SM, OOR, ST, Pincount Switch, and displays the ones that are actuated on the right pinsetter.

EXT SW (Right) - This selection checks the external switches Ball Detect, Foul, Set And Reset and displays the ones that are actuated on the right pinsetter.

Diagnostic Modes

Trouble Diagnostics

The GS Certified Pre-owned pinsetter contains a means of diagnosing pinsetter problems and will shut down a pinsetter if a fault is detected. When a problem occurs, the pinsetter will shut down and the trouble light on the top of the elevator will start to flash. The error code displayed on the LCD Display at the top of the Nexgen Controller can be used to diagnose the problem.

Contact Closure Diagnostics (Switch Diagnostics)

In addition to trouble diagnostics, the GS Certified Pre-owned pinsetter is capable of performing two diagnostic modes for testing pinsetter operations; one mode, contact closure diagnostics, checks the switches on the pinsetter and displays which switches are used during the time the check is being made. This mode can be used to verify that switches are working properly and the wiring between the Nexgen Controller box and the individual switches is correct.

Machine Cycle Diagnostics

The other mode, machine cycle diagnostics, puts the pinsetter into a continuous operating cycle in which the pinsetter operates as if it was in a ten pin bowling mode, with the following exceptions. Instead of waiting for a ball detect, a five second time signal from the CPU starts the pinsetter cycle. The pinsetter will continue to set, reset, sweep and reload pins as long as it is switched into the diagnostic mode. Fouls will be ignored during the diagnostics, and in Frameworkx scoring systems, pinsetter cycles will not be counted at the Manager's Control location. Diagnostic faults (failures) are active during diagnostics and can stop the pinsetter if a jam or some form of failure is detected.

Using the Diagnostics

Contact Closure Diagnostics (Switch Diagnostics)

1. The contact closure diagnostics can only be performed when both pinsetters are off (stop/run switches in the stop positions) The pinsetter is selected by having the following conditions available.
 - a. The trouble light cannot be lit.
 - b. The rear mechanic switch on.
 - c. Both the left and the right stop/run switches on the Nexgen Controller box must be switched to the “stop” position. Refer to *Figure 3-5*
 - d. To activate Contact Closure diagnostics, press the [Mode] key on the control panel until the mode “SW Diag” appears on the display.
 - e. Press the [Enter] key to step through the display options.

Pin SW (Left) - Displays the pinholder switches that are actuated on the left pinsetter. A “-” indicates the switch is open.

Table SW (Left) - Display switches A, B, C, D, TS1, and TS2 of the left pinsetter if actuated. A “-” indicates the switch is open.

Mach SW (Left) - Displays switches EC, G, SM, OOR, ST, and SS (Pincount Switch) of the left pinsetter if actuated. A “-” indicates the switch is open.

EXT SW (Left) - Displays the Ball Detect, Foul, Set And

Reset Switches if actuated for the left pinsetter. A “-” indicates the switch is open.

Pin SW (Right) - Displays the pinholder switches that are actuated on the right pinsetter. A “-” indicates the switch is open.

Table SW (Right) - Display switches A, B, C, D, TS1, and TS2 of the right pinsetter if actuated. A “-” indicates the switch is open.

Mach SW (Right) - Displays switches EC, G, SM, OOR, ST, and SS (Pincount Switch) of the right pinsetter if actuated. A “-” indicates the switch is open.

EXT SW (Right) - Displays the Ball Detect, Foul, Set And Reset Switches if actuated for the right pinsetter. A “-” indicates the switch is open.

Machine Cycle Diagnostics

1. To enter into this mode, the following conditions are necessary.
 - a. The trouble light cannot be lit.
 - b. The rear mechanic switch must be on.
 - c. Either the left or right stop/run switch on the Nexgen Controller box must be switched to the “stop” position. This will be dependent on which pinsetter is being tested. Refer to *Figure 3-5*
2. To activate cycle diagnostics, press the [Mode] key on the control panel until the mode “Diag” appears on the display.
3. Turn either the left or right stop/run switch on the Nexgen Controller to the “run” position. This will be dependent on which pinsetter is being tested.
4. If a pinsetter stops during diagnostics and the trouble light is lit, check the error code displayed on top of the Nexgen Controller box. Refer to *Figure 3-5*

NOTE: In order to see error codes 50-59 (Detect 1 - Detect 9, Detect 10) in Machine Diagnostics, the Enable 50 ERR must be set to Y. See Pages 3-19 & 3-22 for an explanation of the pinsetter setup.

5. Tables 3-13 and 3-14 will give an indication of the failure and where to start looking for the problem. The displayed code will not pinpoint the problem in all cases. For further explanation of the codes, refer to the Troubleshooting section of this manual.

Invalid Machine State	Spotting Tongs Switch	Table		Sweep Assembly			
		Position	"A" Switch	"G" Switch		"SM" Switch	
0 (90) (Invld 0)	Closed	Home	Closed	Open	Sweep Up	Open	Not Forward
1 (91) (Invld 1)	Closed	Not Home	Open	Open	Sweep Up	Open	Not Forward
2 (92) (Invld 2)	Closed	Not Home	Open	Closed	Sweep Down	Open	Not Forward
3 (93) (Invld 3)	Open	Home	Closed	Open	Sweep Up	Open	Not Forward
4 (94) (Invld 4)	Open	Not Home	Open	Open	Sweep Up	Open	Not Forward
5 (95) (Invld 5)	Open	Not Home	Open	Closed	Sweep Down	Open	Not Forward

Table 2. Invalid Machine States.

NOTE: Invalid machine states usually indicate a problem exists with one of the following:

1. Faulty table or sweep motor break.
2. Spotting tong clutch malfunctioning.
3. Defective A, G, SM, or ST switch.

Std. Code	Extended Code	
P0	Pin OOR	Out-of-Range
01	Pin1 Ld	Pin Loading Time Out Pin 1
02	Pin2 Ld	Pin Loading Time Out Pin 2
03	Pin3 Ld	Pin Loading Time Out Pin 3
04	Pin4 Ld	Pin Loading Time Out Pin 4
05	Pin5 Ld	Pin Loading Time Out Pin 5
06	Pin6 Ld	Pin Loading Time Out Pin 6
07	Pin7 Ld	Pin Loading Time Out Pin 7
08	Pin8 Ld	Pin Loading Time Out Pin 8
09	Pin9 Ld	Pin Loading Time Out Pin 9
10	Pin10 Ld	Pin Loading Time Out Pin 10
50	Detect10	#10 Pin Not Detected in Diagnostics
51	Detect1	#1 Pin Not Detected in Diagnostics
52	Detect2	#2 Pin Not Detected in Diagnostics
53	Detect3	#3 Pin Not Detected in Diagnostics
54	Detect4	#4 Pin Not Detected in Diagnostics
55	Detect5	#5 Pin Not Detected in Diagnostics
56	Detect6	#6 Pin Not Detected In Diagnostics
57	Detect7	#7 Pin Not Detected in Diagnostics
58	Detect8	#8 Pin Not Detected in Diagnostics
59	Detect9	#9 Pin Not Detected in Diagnostics
60	A Found	Switch A is Not Expected But Found
61	B Found	Switch B is Not Expected But Found

Std. Code	Extended Code	
62	C Found	Switch C is Not Expected But Found
63	D Found	Switch D is Not Expected But Found
64	SMFound	Switch SM is Not Expected But Found
65	G Found	Switch G is Not Expected But Found
66	STFound	Switch ST Is Not Expected But Found
67	OORFound	SW. OOR is Not Expected But Found
70	A Ntfnd	Switch A Expected But Not Found
71	B Ntfnd	Switch B Expected But Not Found
72	C Ntfnd	Switch C Expected But Not Found
73	D Ntfnd	Switch D Expected But Not Found
74	SM Ntfnd	Switch SM Expected But Not Found
75	G Ntfnd	Switch G Expected But Not Found
76	STNtfnd	Switch ST Expected But Not Found
90	Invid 0	Invalid Machine State 0
91	Invid 1	Invalid Machine State 1
92	Invid 2	Invalid Machine State 2
93	Invid 3	Invalid Machine State 3
94	Invid 4	Invalid Machine State 4
95	Invid 5	Invalid Machine State 5
EJ	ElevJam	Elevator Jam
EL	Pin Cnt	Pin Count Switch Shorted for 5 Seconds
J1	TS1 Jam	Jam Switch TS1
J2	TS2 Jam	Jam Switch TS2 (Tower)
	BA	Accelerator Motor (overload)

Table 3-12. Error Codes.

NOTE: Nexgen Electronics displays either Standard Code or Extended Code.

Ball Detect - Photocell Triggering

The photocell is an optical device used to detect a ball rolling down the lane. It consists of a transmitter/receiver device and a retroreflector. The transmitter/receiver device is mounted on the ball return kickback and the retroreflector is mounted on the division kickback. They are positioned directly across from each other at 25 mm (1") above the capping. Refer to *Figures 3-13* and *3-14*.

The transmitter sends an infrared beam across the lane to the retroreflector which reflects the beam back to the receiver. When any object cuts this beam, the receiver sends a pulse to the Pinsetter CPU. The Pinsetter CPU then cycles the corresponding pinsetter.

WARNING: A strong light source such as a camera's electronic flash may cause the pinsetter to trigger.

- (1) KICKBACK
- (2) PHOTOCELL ASSEMBLY
- (3) CAPPING

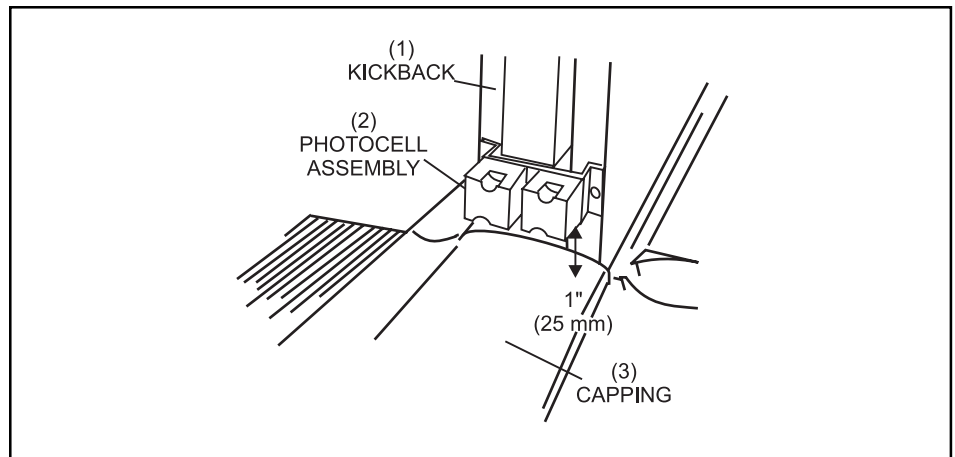

Figure 3-13. Ball Detect.

- (1) DIVISION KICKBACK
- (2) RETROREFLECTOR
- (3) CAPPING

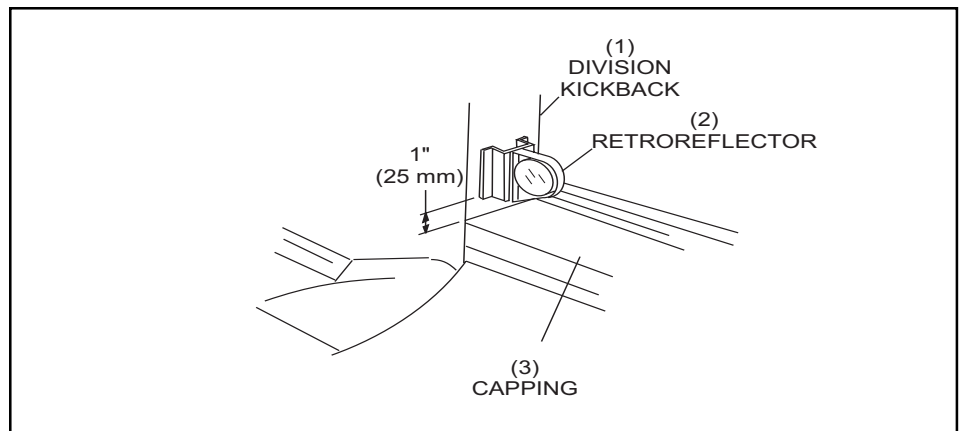

Figure 3-14. Retroreflector.

Foul Detect

The foul detect is located at the foul line and is mounted between the pair of lanes on the ball return capping. Retroreflectors, mounted on divisions, return the beam to the foul detect. A foot or some other object will interrupt this beam and a signal is sent to the Pinsetter CPU to make the pinsetter set ten new pins if the machine is in a first ball foul situation while bowling a ten pin game format. The foul detect will not register a foul when the beam is broken by a bowling ball.

Reset Button

A bowler's reset button is located on the side of the ball rack. This switch parallels the reset switch on the Nexgen Controller box and rear Control Box on the elevator. Its purpose is to cycle the pinsetter to the next ball.

Cables and Wiring

Cable Connections

The Nexgen box interconnects with several external devices that assist in the operation of the pinsetters.

The cables are labeled for easy identification in the event the Nexgen box needs to be replaced. However, care must be exercised when making these changes as problems can occur if cables are swapped between the left and right connections. Refer to *Figure 3-15*.

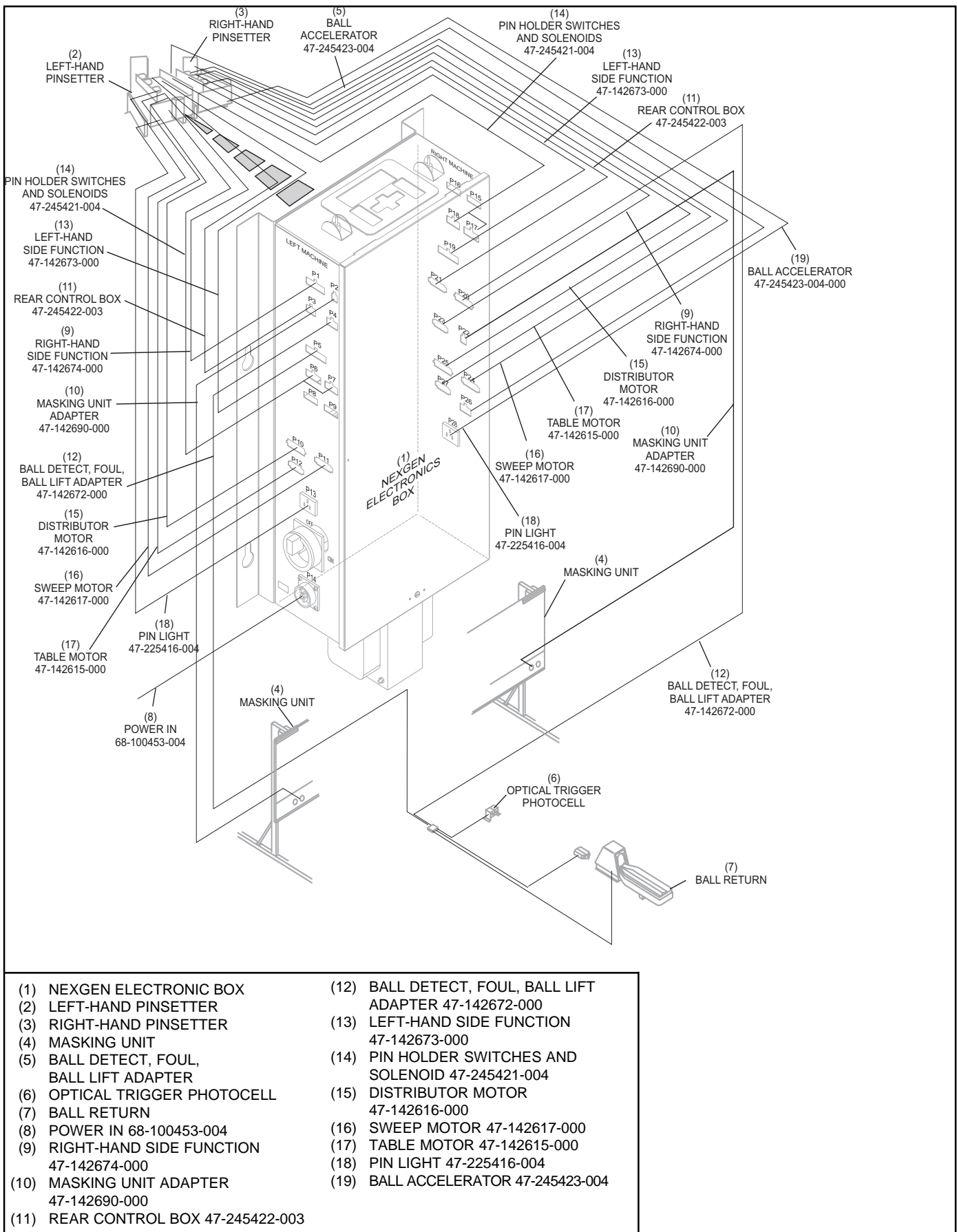

Figure 3-15. GS Certified Pre-owned Pinsetter with Nexgen Electronics.

INTENTIONALLY BLANK PAGE

11 X 17 HERE

BACK OF 11 X 17 HERE

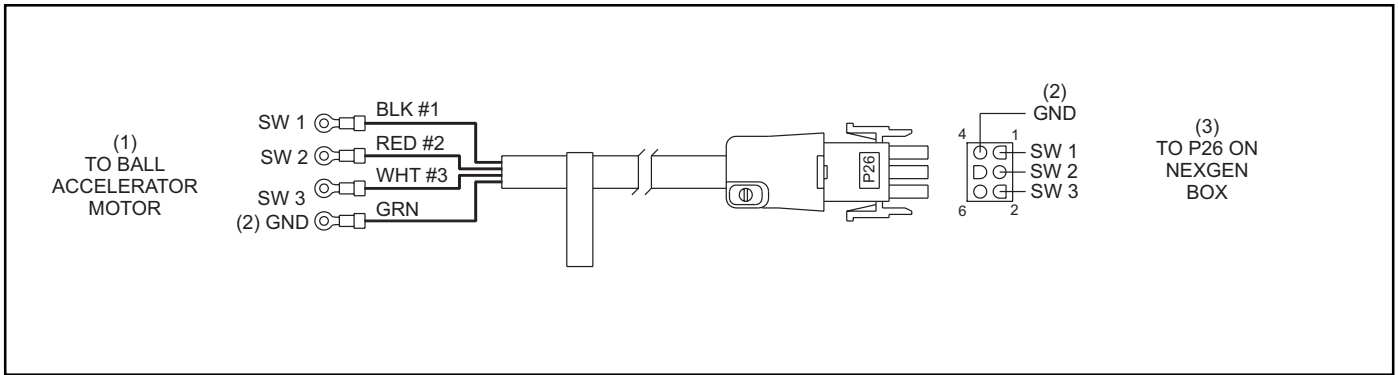

Figure 3-17. Ball Accelerator Motor Cable Assembly (Part No. 47-245423-004)

- (1) TO BALL ACCELERATOR MOTOR (2) GROUND (3) TO P26 ON NEXGEN BOX

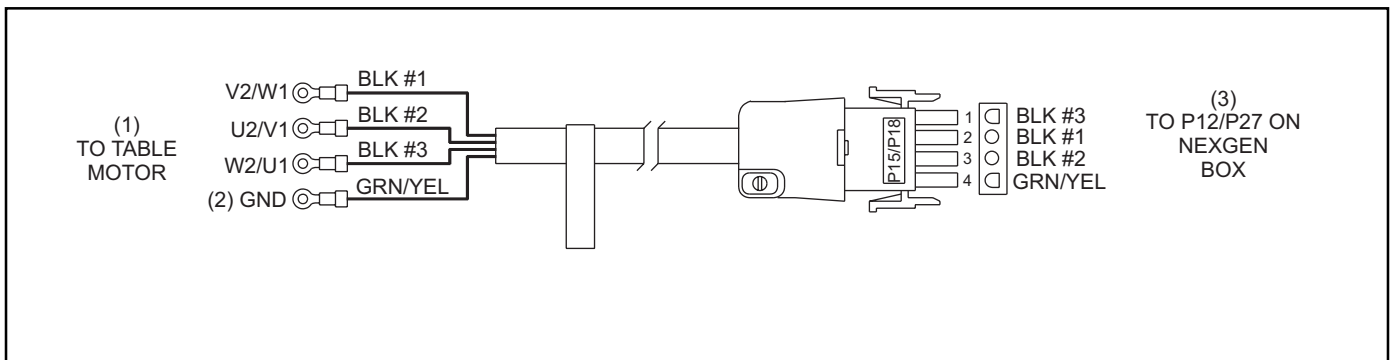

Figure 3-18. External Table Motor Cable Assembly (Part No. 47-142615-000)

- (1) TO TABLE MOTOR (2) GROUND (3) TO P15/P18 ON NEXGEN BOX

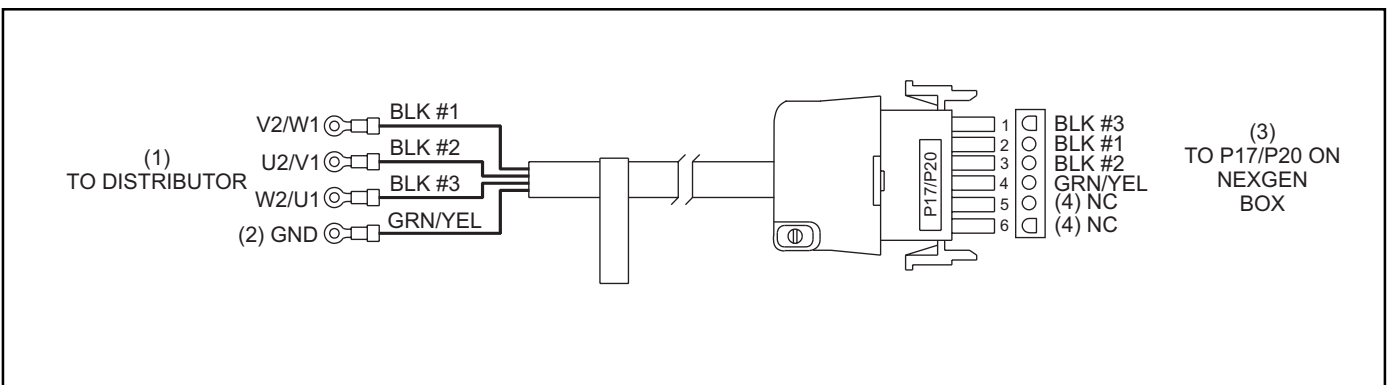

Figure 3-19. External Distributor Motor Cable Assembly (Part No. 47-142616-000)

- (1) TO DISTRIBUTOR (2) GROUND (3) TO P17/P20 ON NEXGEN BOX (4) NO CONNECTION

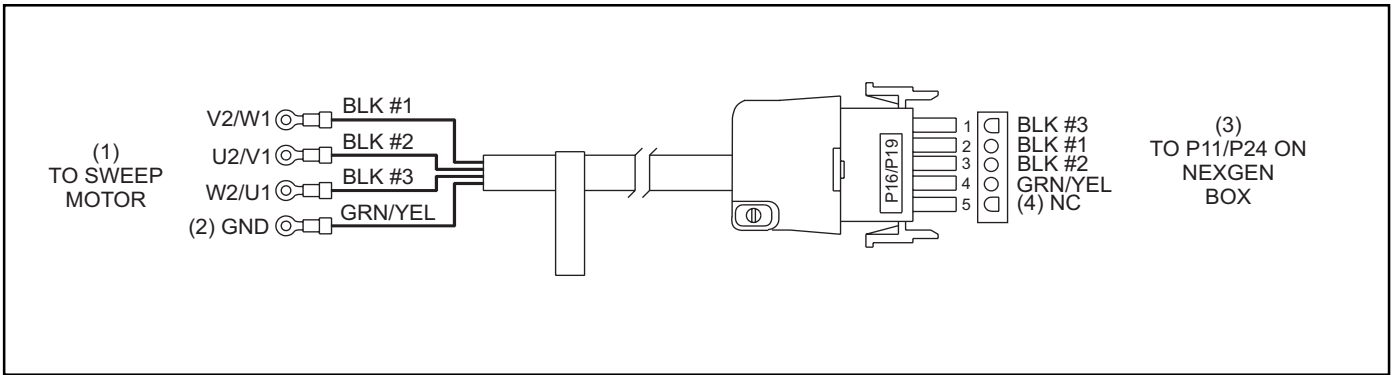

Figure 3-20. Sweep Motor Cable Assembly (Part No. 47-142617-000)

- (1) TO SWEEP MOTOR
- (2) GROUND
- (3) TO P11/P24 ON GS NEXGEN BOX
- (4) NO CONNECTION

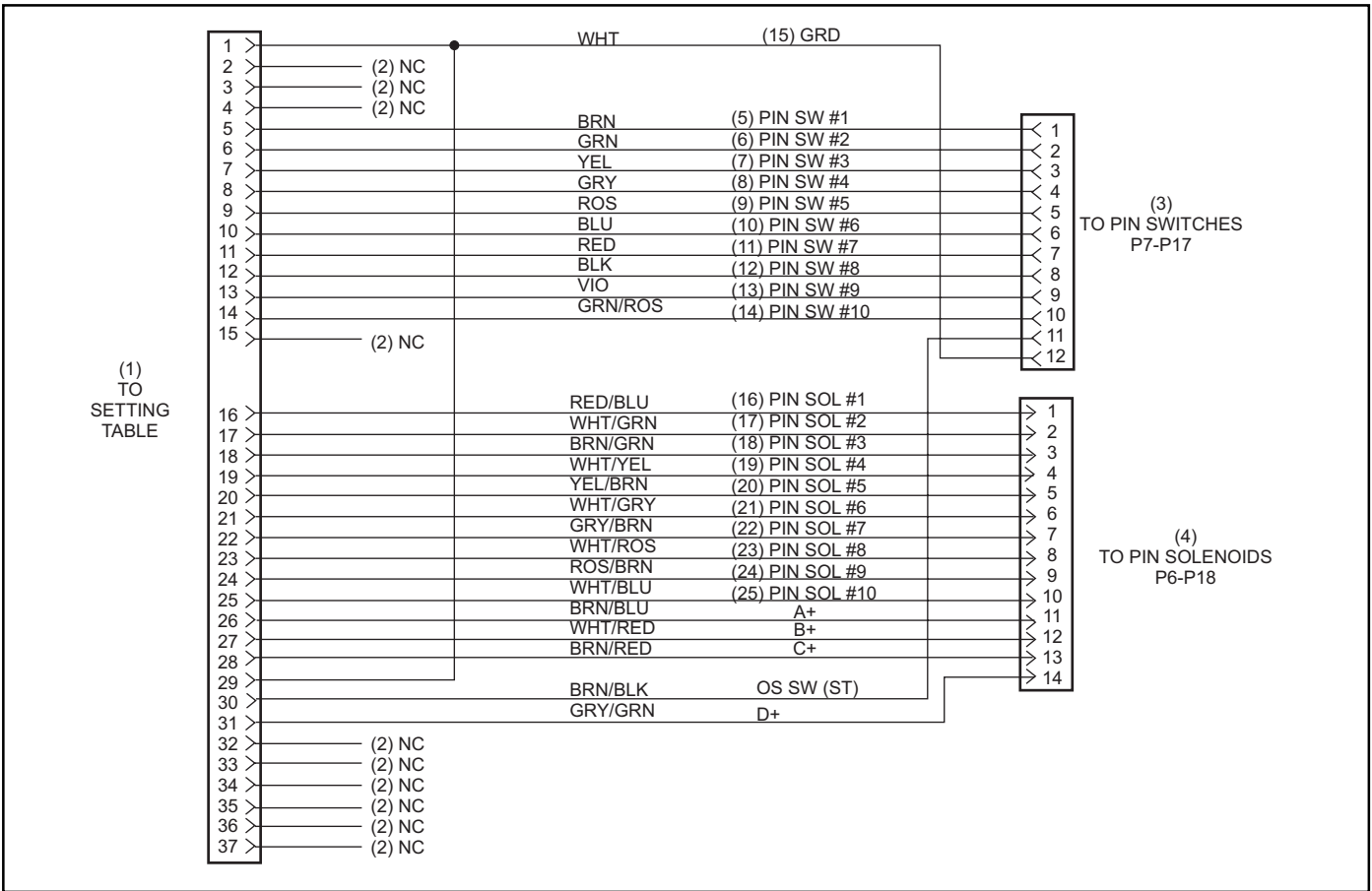

Figure 3-21. External Setting Table Cable Assembly (Part No. 47-245421-004)

- (1) TO SETTING TABLE
- (2) NO CONNECTION
- (3) TO PIN SWITCHES P7-P17
- (4) TO PIN SOLENOIDS P6-P18
- (5) PIN SWITCH #1
- (6) PIN SWITCH #2
- (7) PIN SWITCH #3
- (8) PIN SWITCH #4
- (9) PIN SWITCH #5
- (10) PIN SWITCH #6
- (11) PIN SWITCH #7
- (12) PIN SWITCH #8
- (13) PIN SWITCH #9
- (14) PIN SWITCH #10
- (15) GROUND
- (16) PIN SOL #1
- (17) PIN SOL #2
- (18) PIN SOL #3
- (19) PIN SOL #4
- (20) PIN SOL #5
- (21) PIN SOL #6
- (22) PIN SOL #7
- (23) PIN SOL #8
- (24) PIN SOL #9
- (25) PIN SOL #10

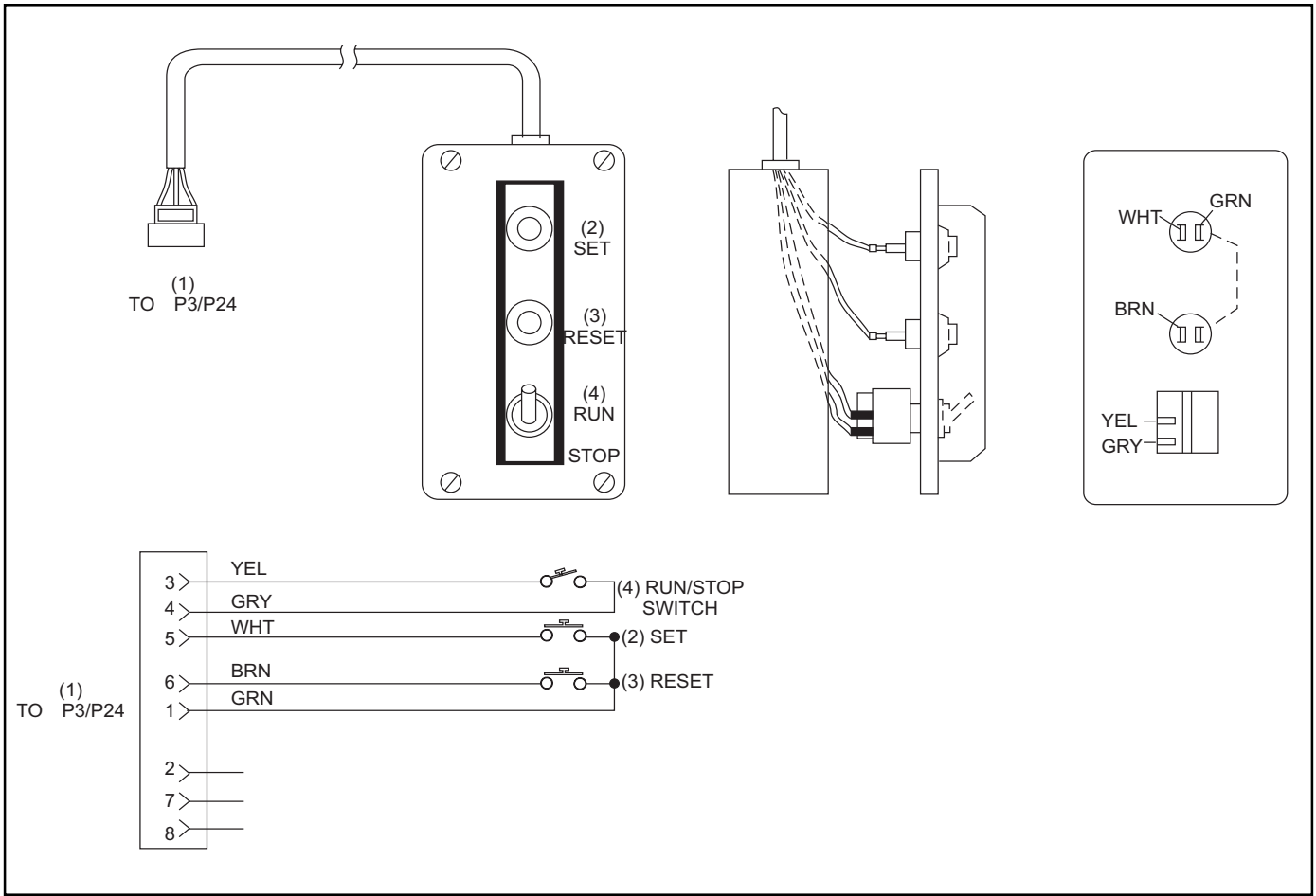

Figure 3-22. Rear Control Box Cable Assembly (Part No. 47-245422-003 or 47-240071-004)

(1) TO P3/P24
 (2) SET

(3) RESET

(4) RUN/STOP SWITCH

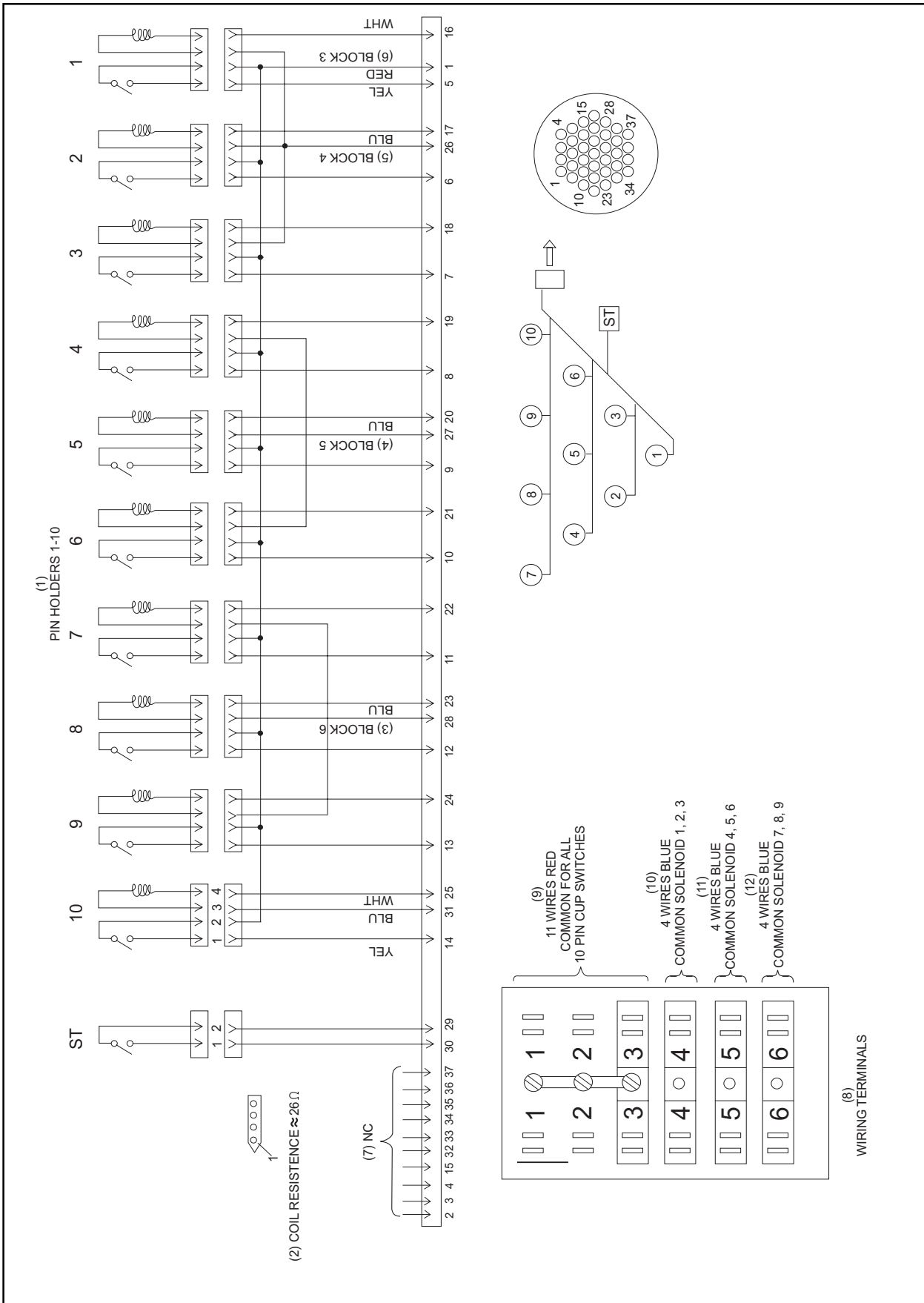

Figure 3-25. Setting Table Cable Assembly (Part No. 47-245585-003)

- (1) PIN HOLDERS 1-10
- (2) COIL RESISTANCE ALMOST EQUAL TO 26 OHMS
- (3) BLOCK 6
- (4) BLOCK 5
- (5) BLOCK 4
- (6) BLOCK 3
- (7) NO CONNECTION
- (8) TERMINALS WIRING
- (9) 11 WIRES RED COMMON FOR ALL PIN CUP SWITCHES
- (10) 4 WIRES BLUE COMMON SOLENOID 1, 2, 3
- (11) 4 WIRES BLUE COMMON SOLENOID 4, 5, 6
- (12) 4 WIRES BLUE COMMON SOLENOID 7, 8, 9

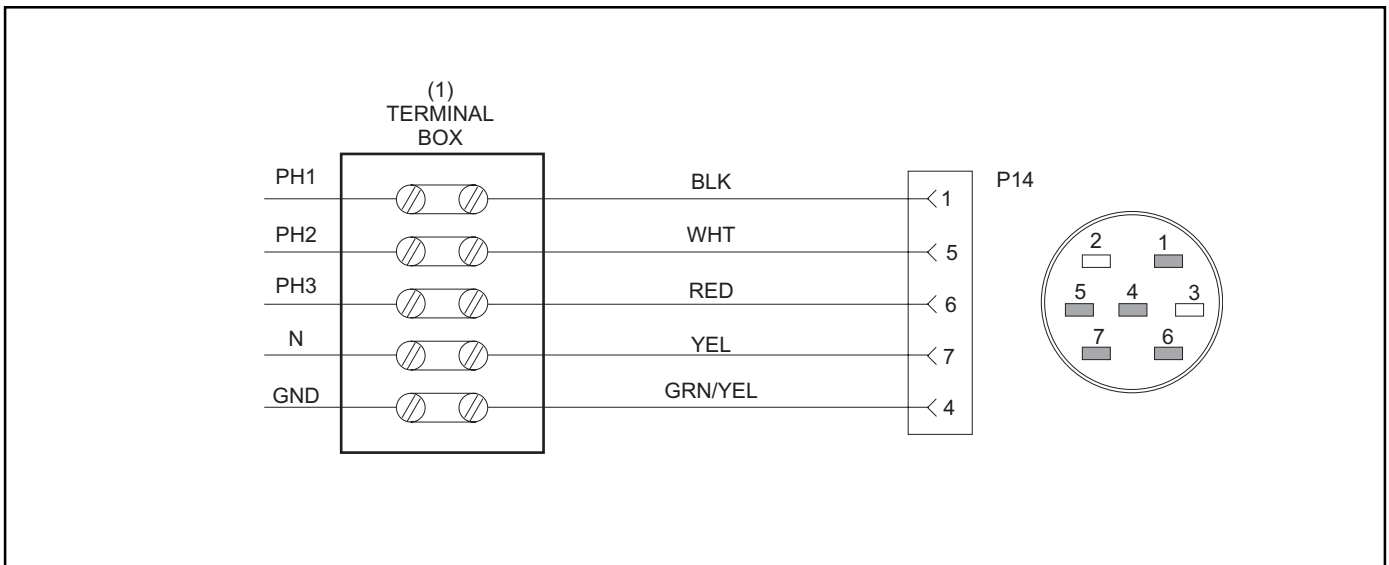

Figure 3-26. 380V x 400V AC-Power Input.

(1) TERMINAL BOX

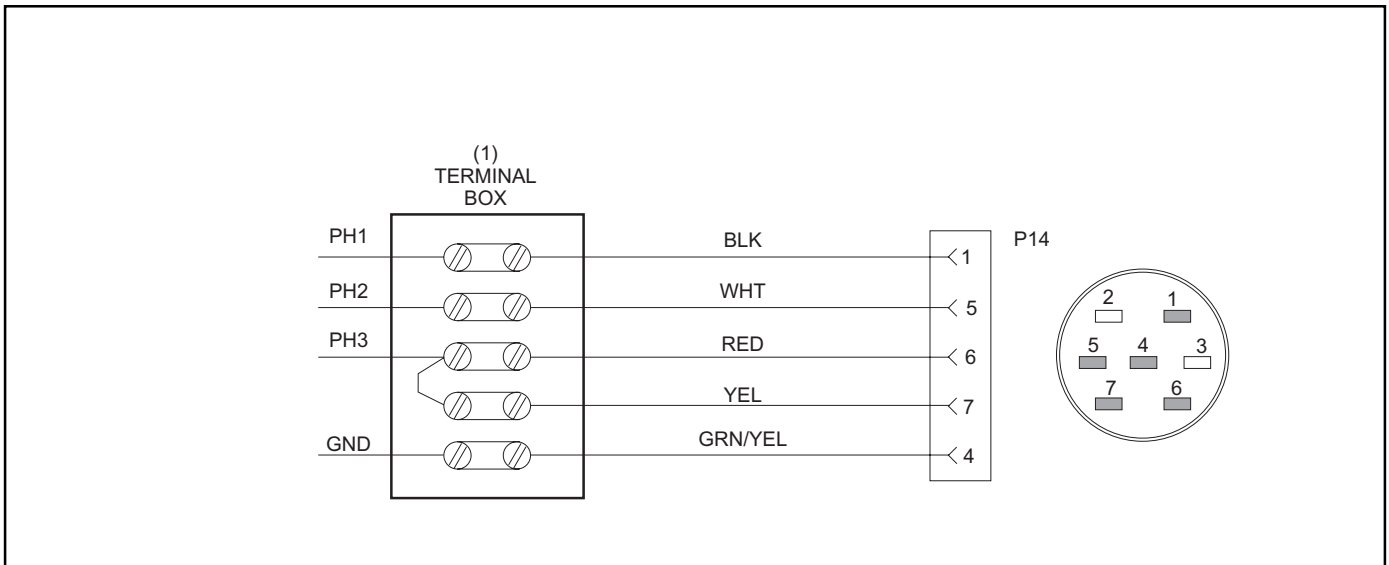

Figure 3-27. 3Ø x 200V - 230V AC-Power Input.

(1) TERMINAL BOX

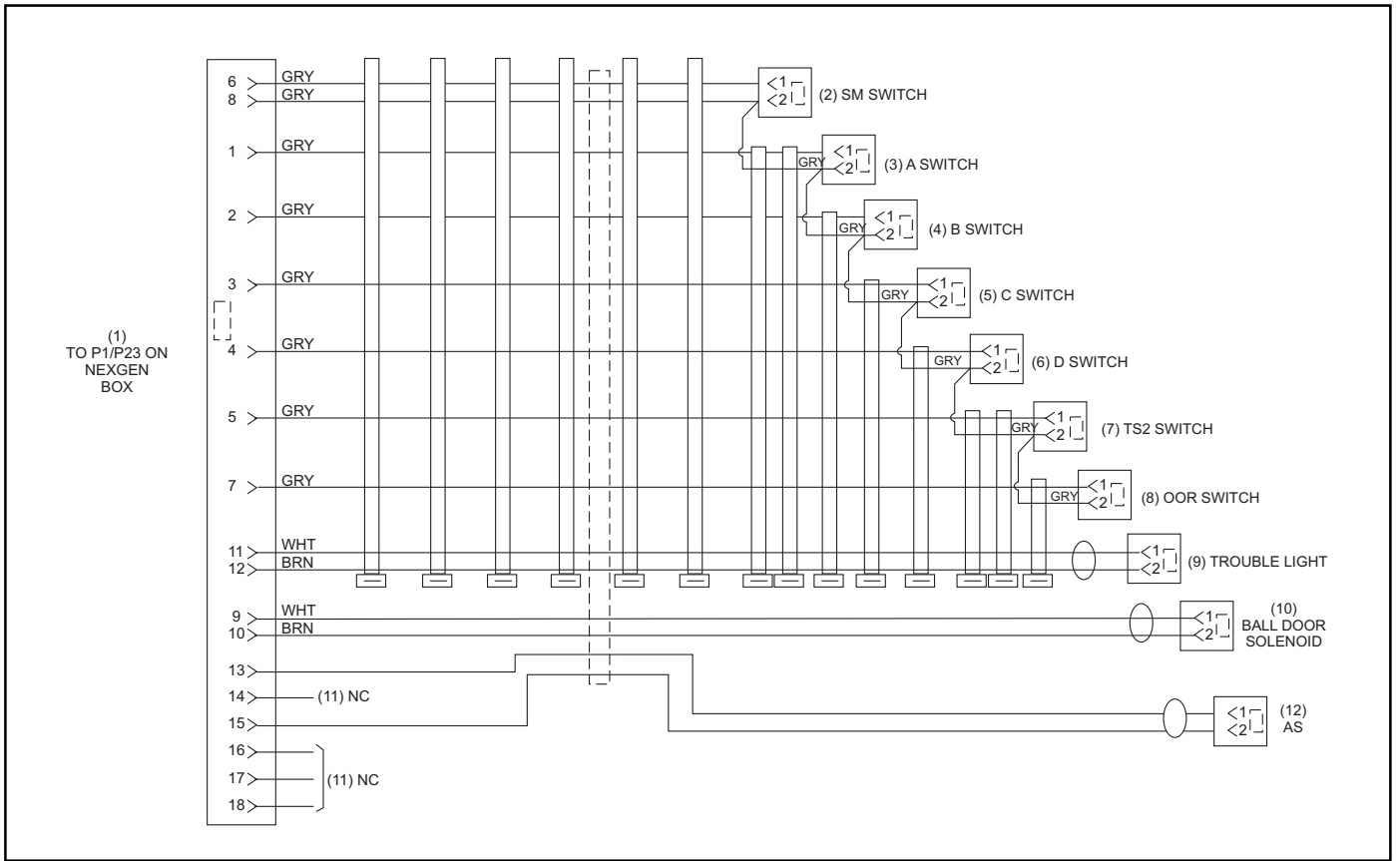

Figure 3-28. Right Side Function Cable (Part No. 47-142674-000)

- | | | |
|-------------------------|-------------------|-------------------------|
| (1) TO P1/P3 NEXGEN BOX | (6) D SWITCH | (10) BALL DOOR SOLENOID |
| (2) SM SWITCH | (7) TS2 SWITCH | (11) NO CONNECTION |
| (3) A SWITCH | (8) OOR SWITCH | (12) AS |
| (4) B SWITCH | (9) TROUBLE LIGHT | |
| (5) C SWITCH | | |

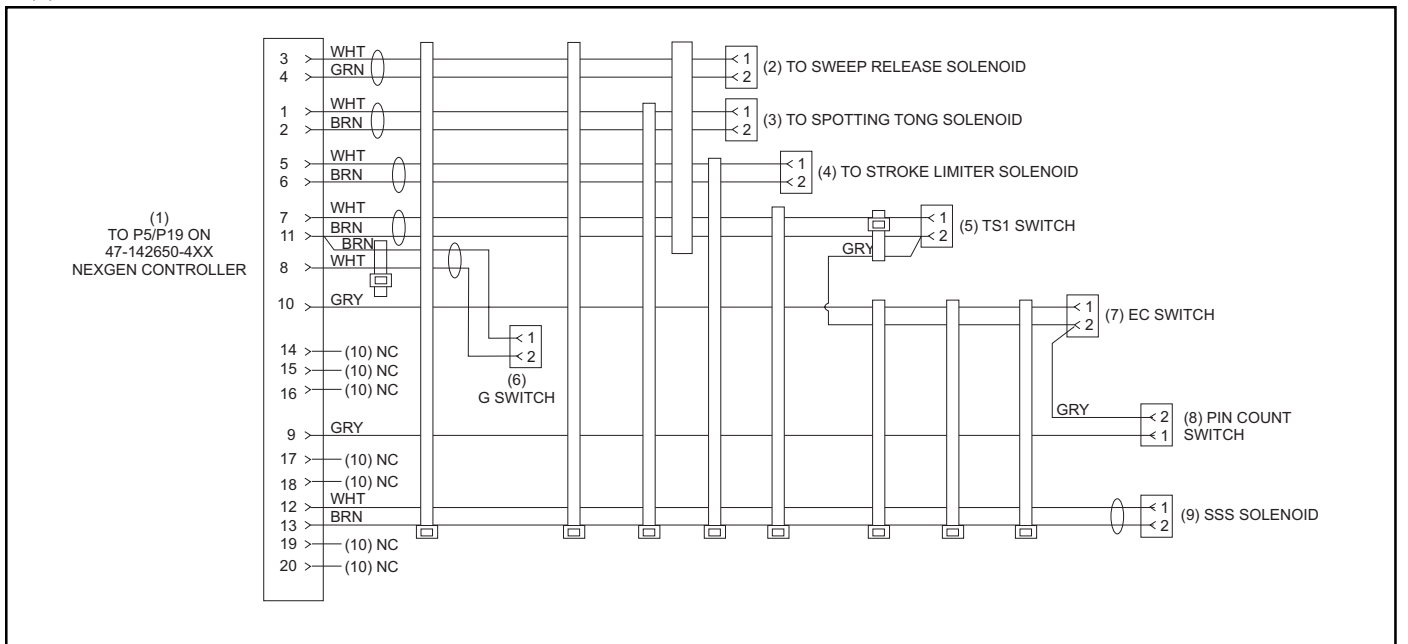

Figure 3-29. Left Side Function Cable (Part No. 47-142673-000)

- | | | |
|--|--------------------------------|----------------------|
| (1) TO P5/P19 ON 47-142650-4XX NEXGEN CONTROLLER LOW VOLTAGE CONTROL BOX | (3) TO SPOTTING TONG SOLENOID | (7) EC SWITCH |
| (2) TO SWEEP RELEASE SOLENOID | (4) TO STROKE LIMITER SOLENOID | (8) PIN COUNT SWITCH |
| | (5) TS1 SWITCH | (9) SHARK SOLENOID |
| | (6) G SWITCH | (10) NO CONNECTION |

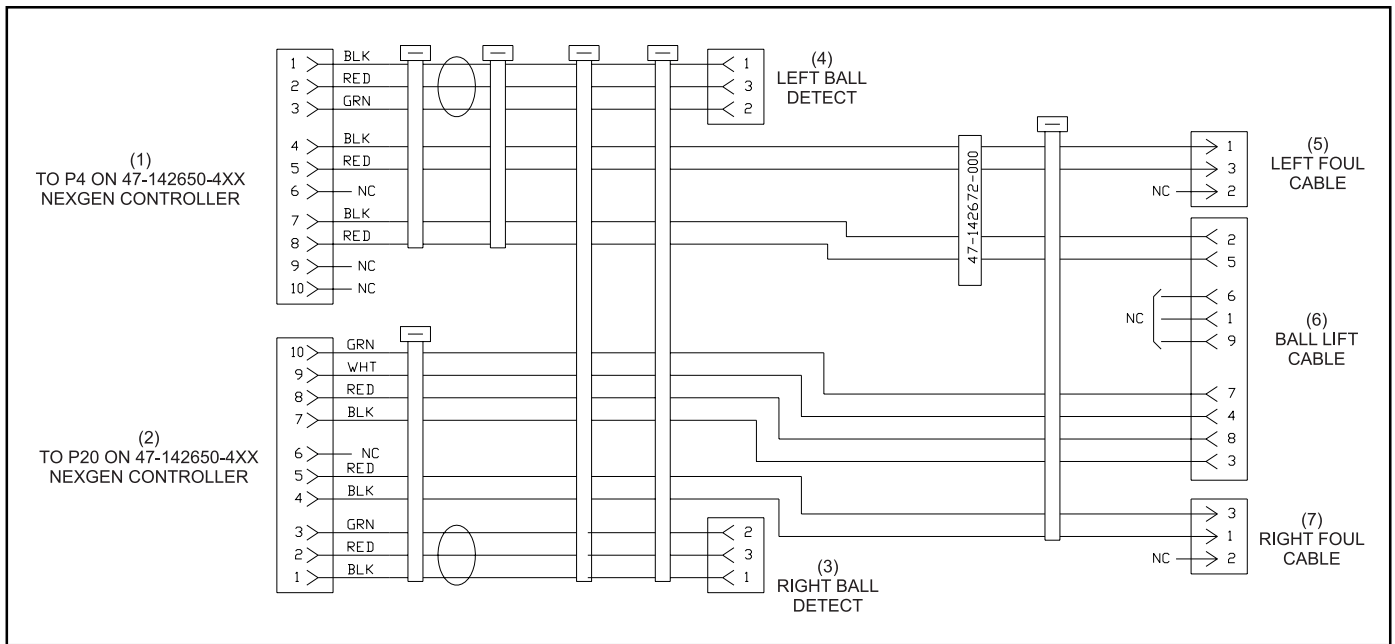

Figure 3-30. Ball Detect/Foul Cable (Part No. 47-142672-000)

- (1) TO P4 ON 47-142650-4XX NEXGEN CONTROLLER
- (2) TO P20 ON 47-142650-4XX NEXGEN CONTROLLER
- (3) RIGHT BALL DETECT
- (4) LEFT BALL DETECT
- (5) LEFT FOUL CABLE
- (6) BALL LIFT CABLE
- (7) RIGHT FOUL CABLE

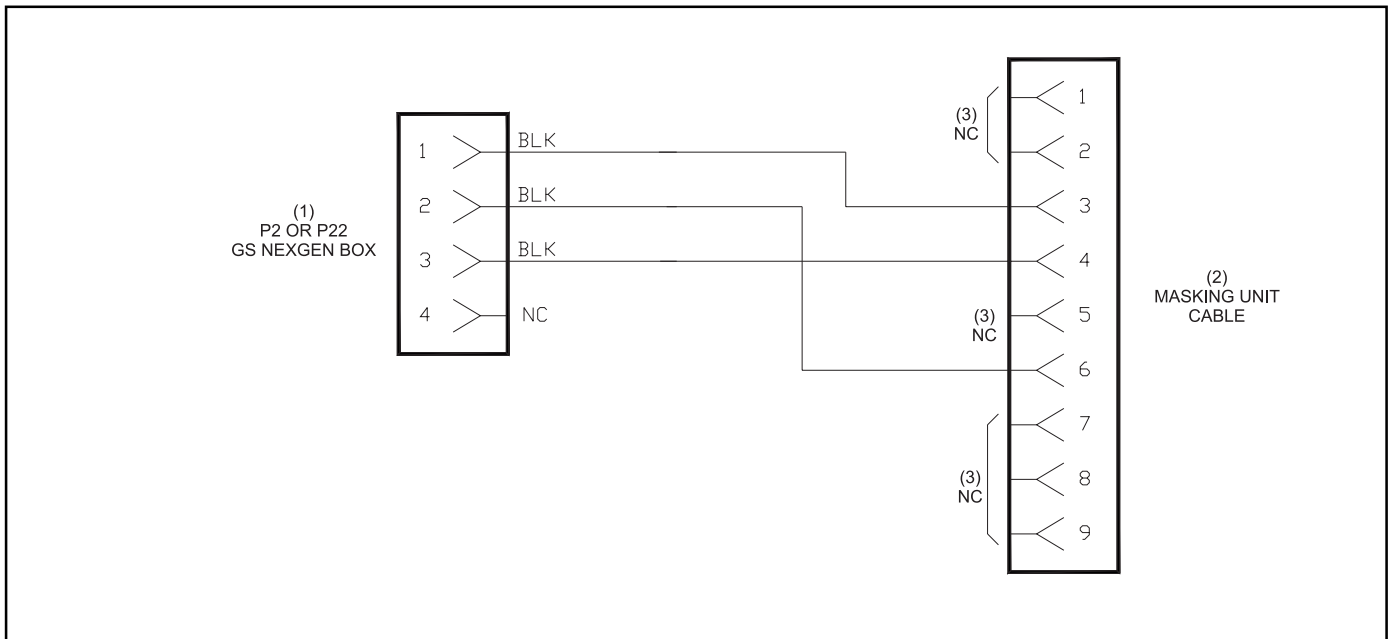

Figure 3-31. Masking Unit Adapter GS Nexgen (Part No. 47-142690-000)

- (1) TO P2 OR P22 NEXGEN BOX
- (2) MASKING UNIT CABLE
- (3) NO CONNECTION