

## **GS Consolidated Box Rear Display 47-861046-000**

### **Packaging**

- 1 Ea. 47-862881-000 Package - GS-X Consolidated GS-X Rear Display
- 1 Ea. 47-862870-000 GS-X Consolidated Rear Display w/Hardware
- 1 Ea. 47-142798-000 Bracket
- 1 Ea. 47-902011-000 Instruction Sheet
- 1 Ea. 47-142778-000 Consolidated Box Display Interface Cable Assembly
- 1 Ea. 47-142779-000 Consolidated Box to Rear Display Cable Assembly
- 1 Ea. 47-142781-000 Consolidated Display Interface



***WARNING! Remove power from the GS Consolidated Box.***

1. Using the paper template located on page 7, drill two 5/32" (4 mm) holes in the bottom of the Consolidated Low Voltage Box, just to the right of center and between the two cable access holes. Refer to *Figure 1*.

**i** **IMPORTANT:** It is important to remove any metal shavings inside the electrical box when finished.

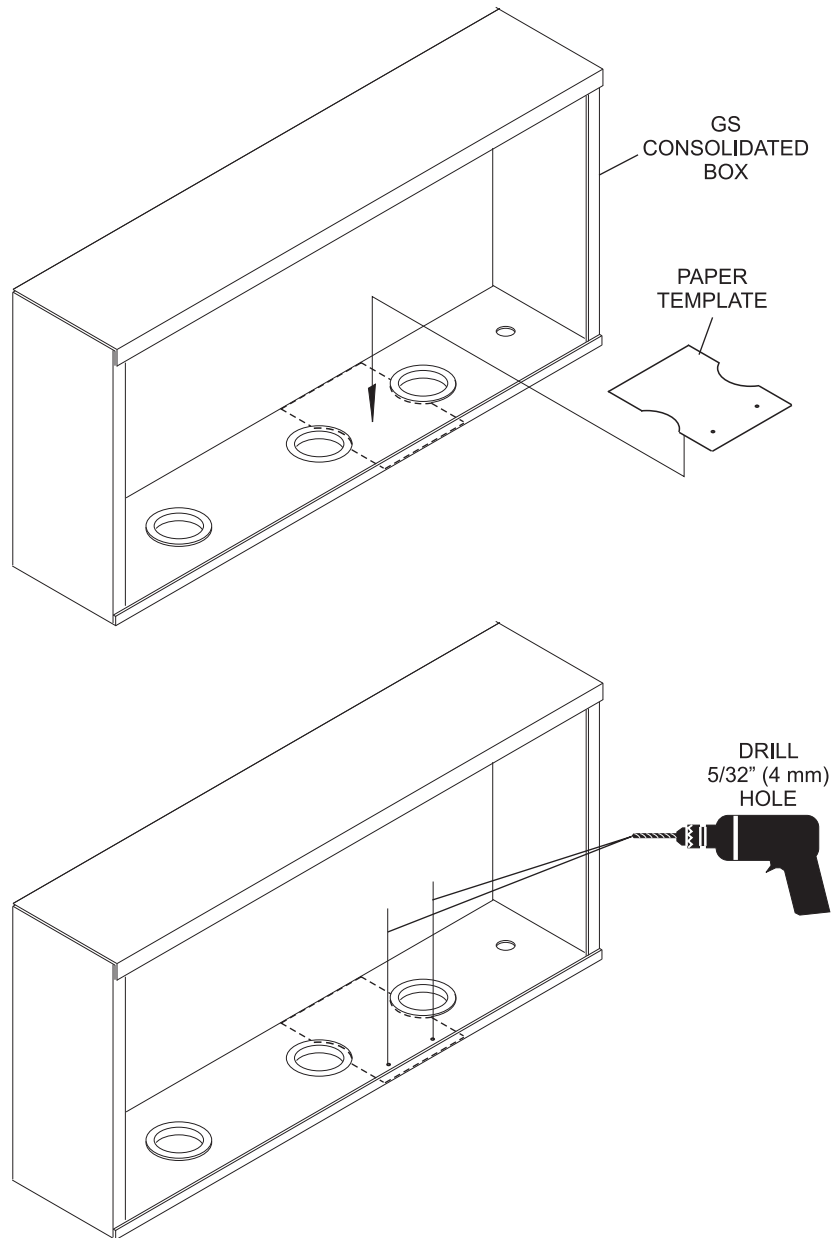

*Figure 1*

2. Install the two supplied metal standoffs (P/N 11-185133-000) in the holes and secure with keps nuts (P/N 11-176005-001). Refer to *Figure 2*.

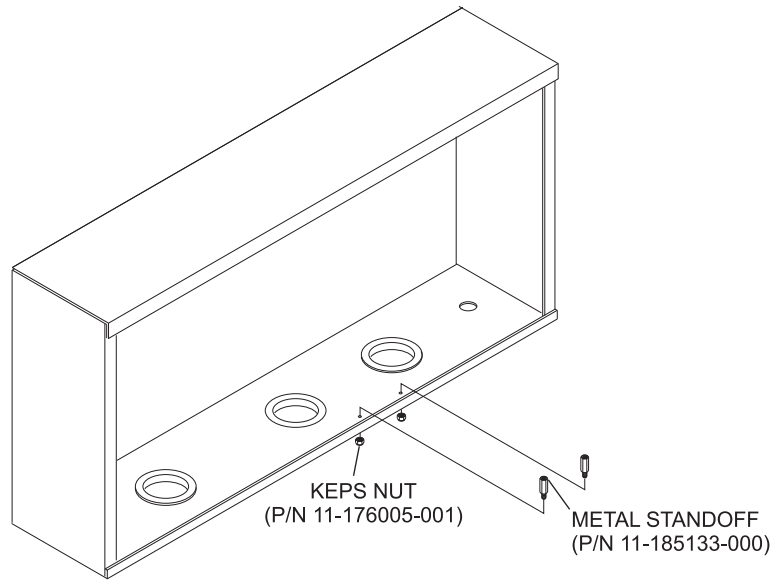

*Figure 2*

3. Remove the backing paper from the plastic standoffs and position the Consolidated Display Interface Board (P/N 47-142754-000) onto the metal standoffs, with "J1" connector on the right hand side and "J2" connector on the left hand side, then secure with two #6-32 x 1/4" pan head w/internal tooth lockwasher machine screws (P/N 11-012020-001). Refer to *Figure 3*.

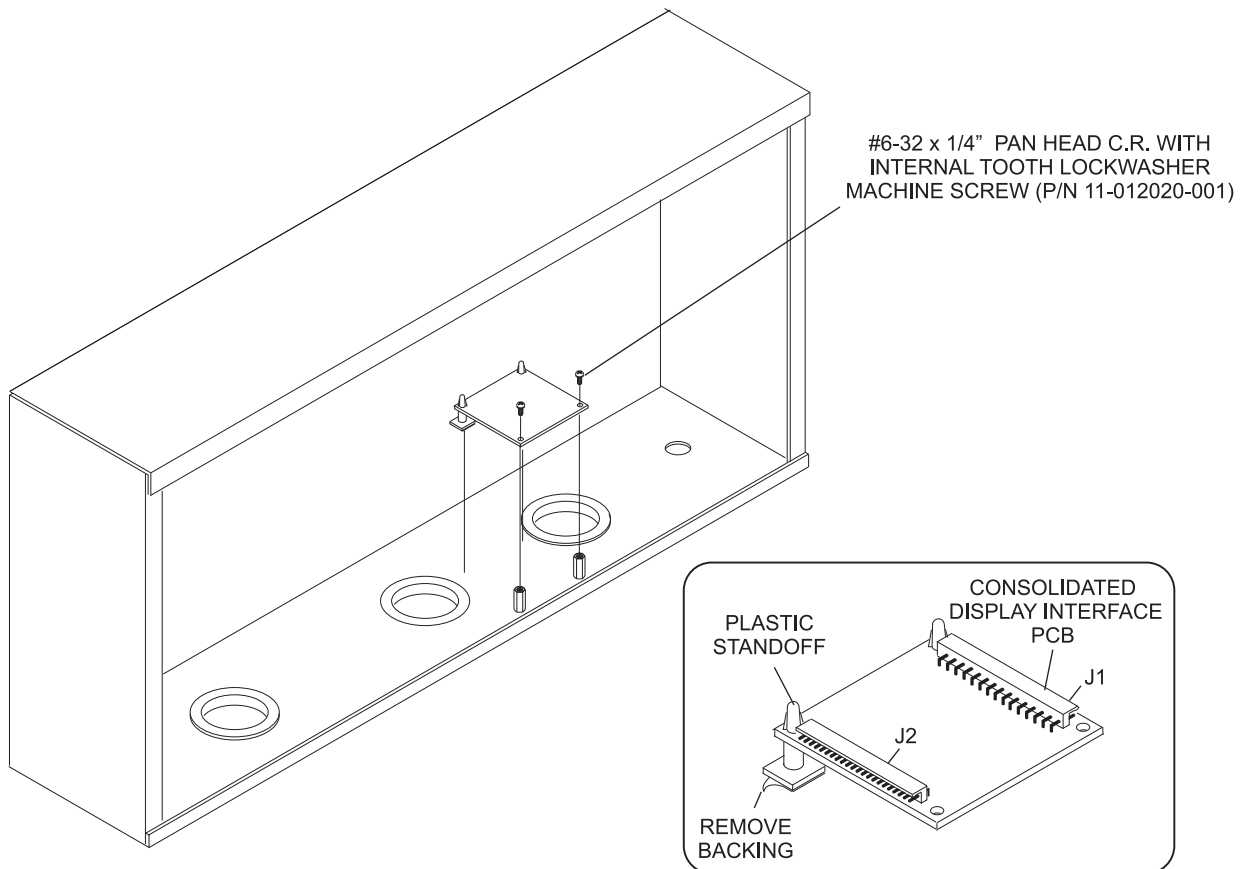

*Figure 3*

4. Connect one end of the 18" cable (P/N 47-142778-000) to "J14" on the CPU board. *Figure 4.*

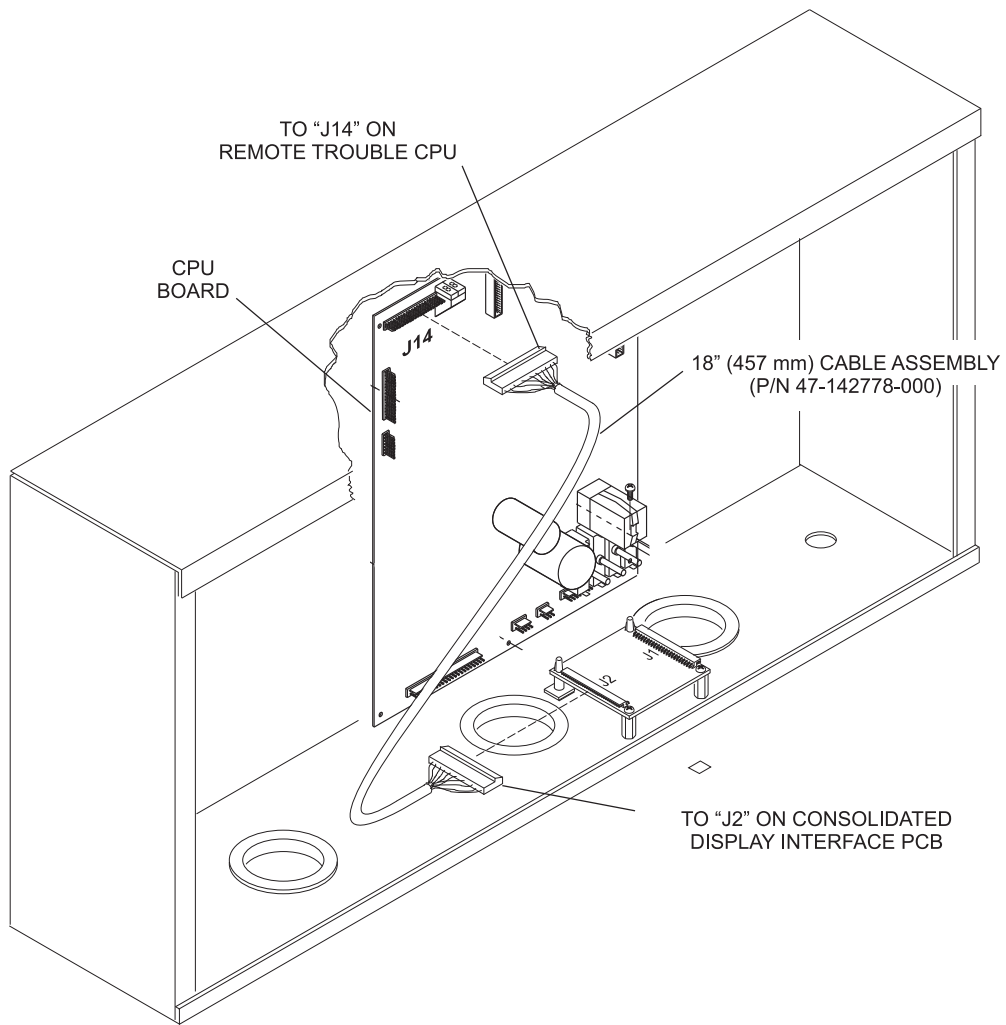

*Figure 4*

5. Connect the other end of 18" cable (P/N 47-142778-000) to "J2" on the Consolidated Display Interface Board. Refer to *Figure 4.*

- Route the 15' (4.57 m) cable (P/N 47-142779-000) through the far R.H. cable access hole of the Low Voltage Box and connect end to "J1" on the Consolidated Display Interface Board. Refer to *Figure 6*.

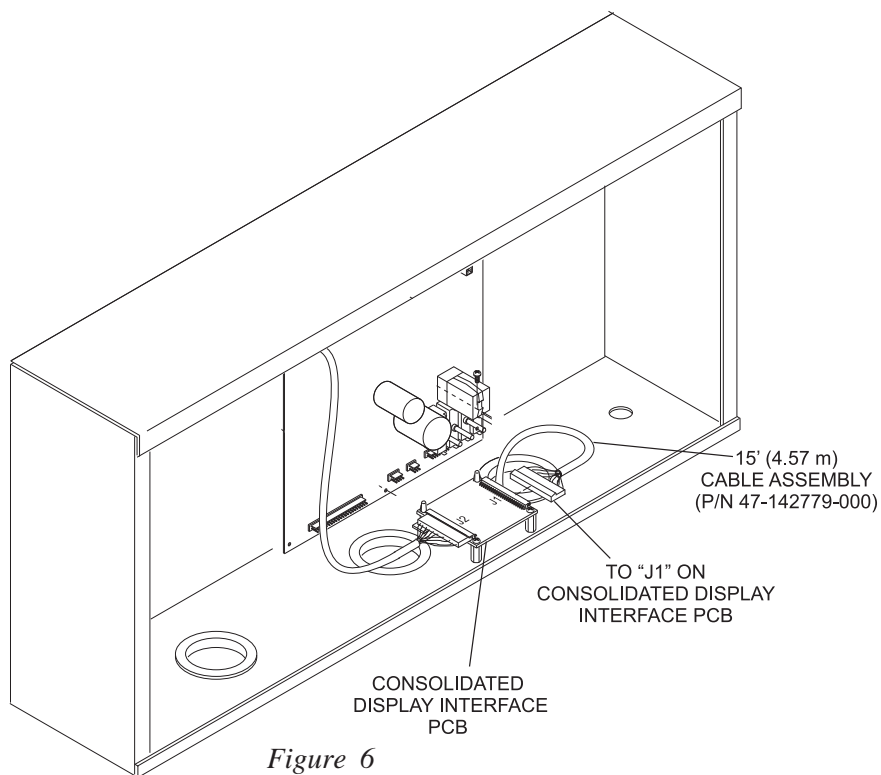

- Continue routing the 15' (4.57 m) cable (P/N 47-142779-000) through the wire channels to rear of the L.H. pinsetter. Refer to *Figure 7*.

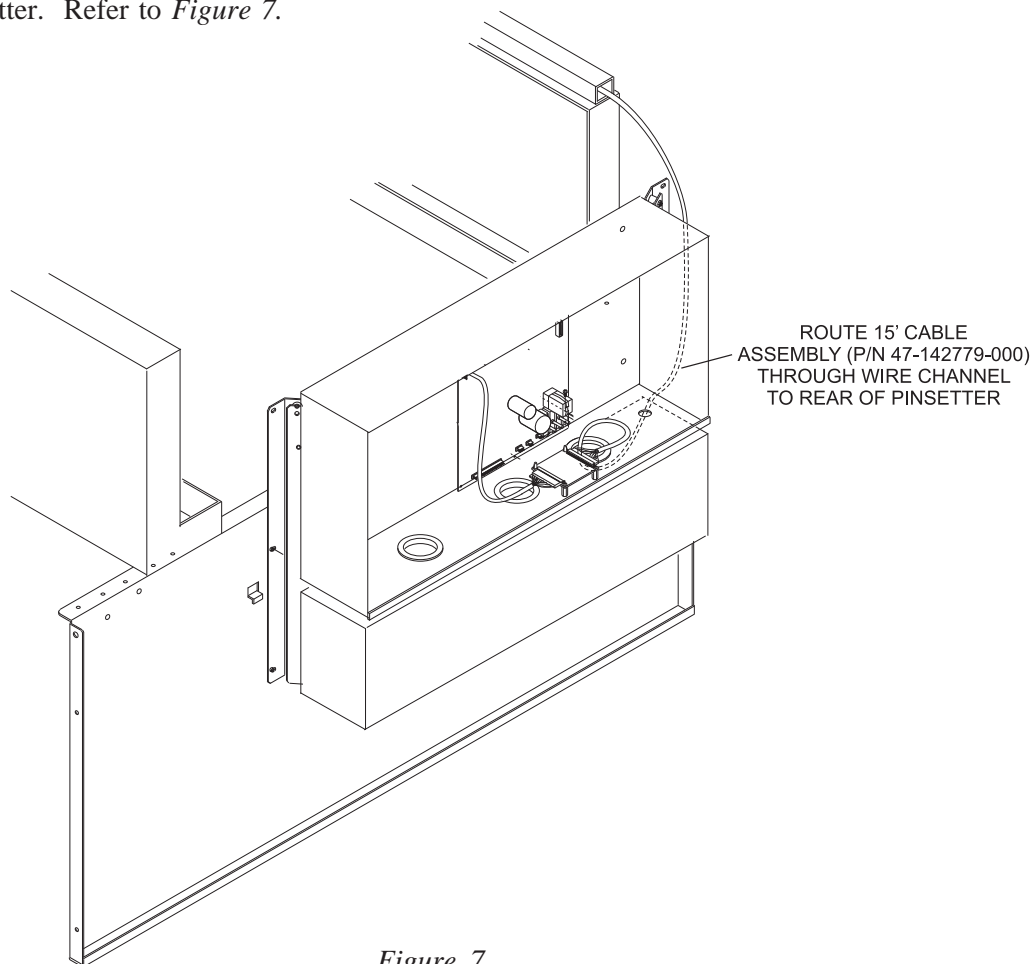

- Use two #8-32 x 5/16" pan head w/internal tooth lockwasher screws (P/N 11-012057-015) to mount the "Consolidated Rear Display" (P/N 47-142784-000) to bracket (P/N 47-142798-000).

**i** *NOTE: Mount Consolidated Rear Display with "J1" connector facing up.*

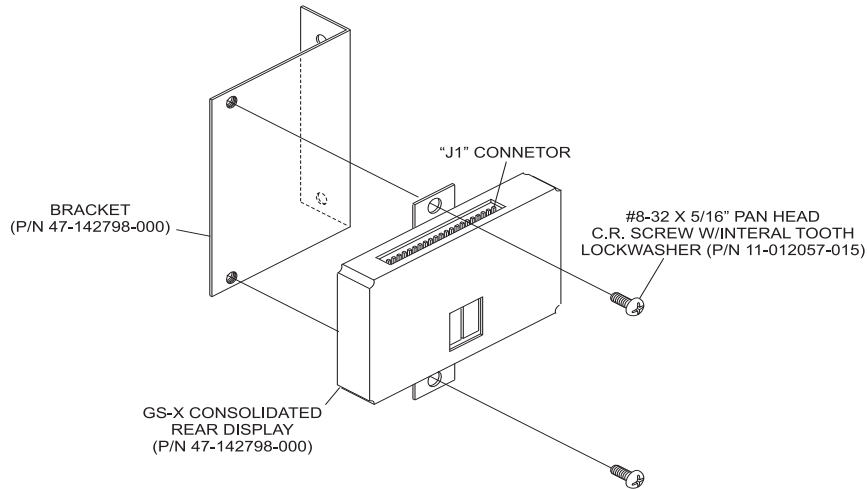

Figure 8

- Mount the consolidated rear display and bracket assembly to the elevator using the supplied #6 X 1" drywall screws (P/N 11-310500-000). Refer to Figure 9.

**i** *NOTE: Mount Consolidated Rear Display in location that allows proper function of any existing doors or guards.*

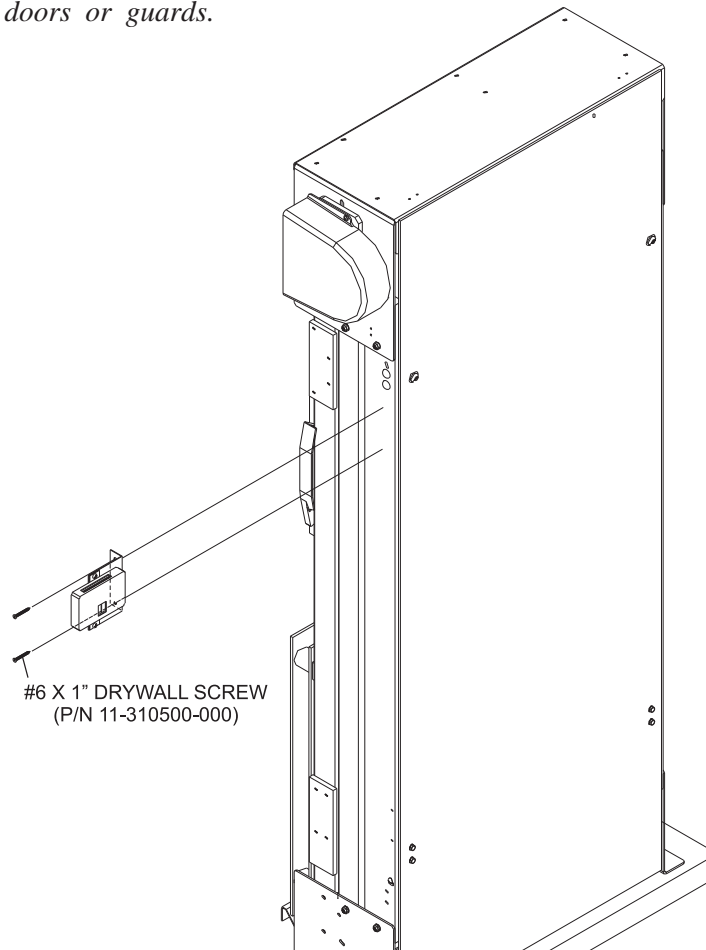
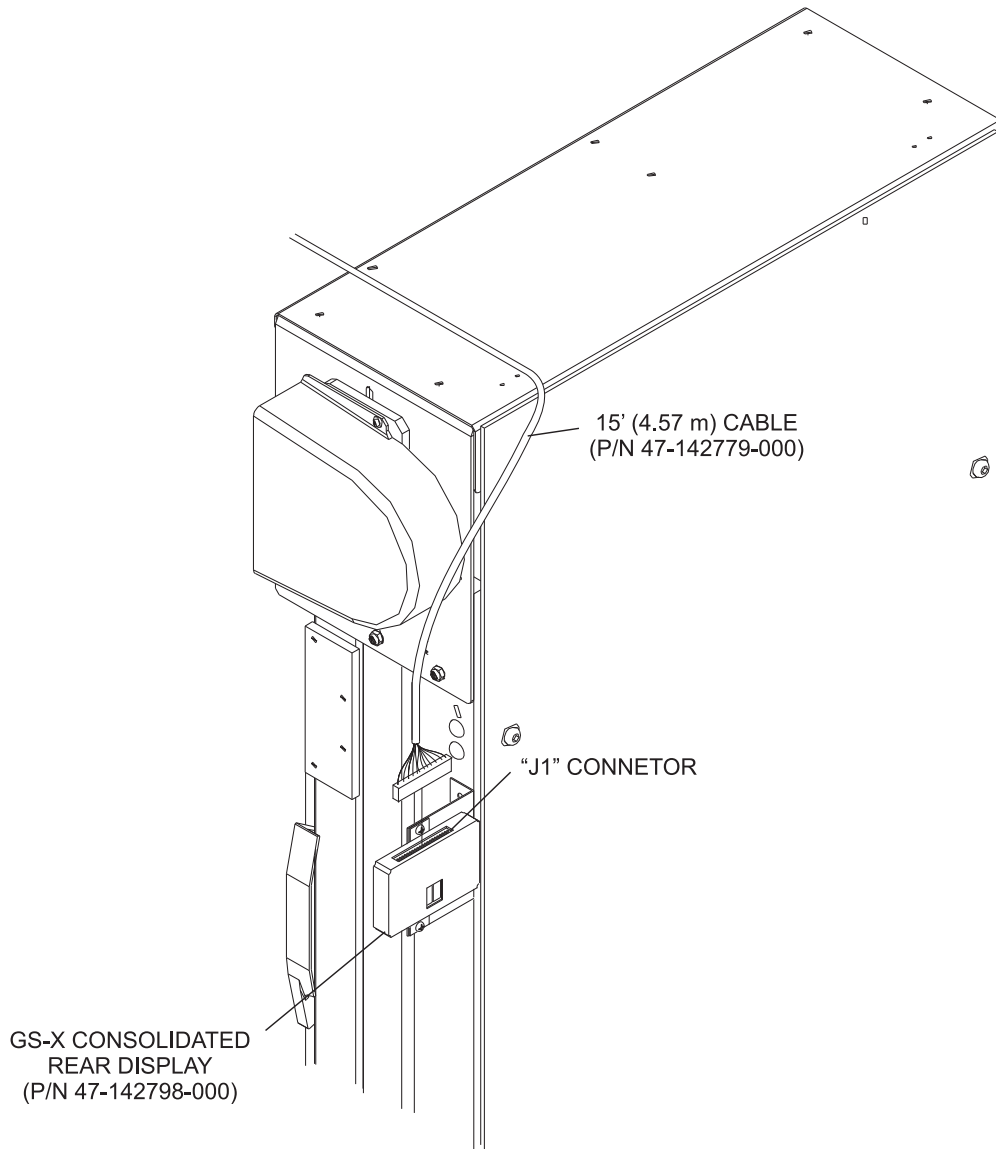

Figure 9

9. Connect the 15' (4.57 m) cable (P/N 47-142779-000) to the "J1" connector on the Consolidated Rear Display. Refer to *Figure 10*.



*Figure 10*

10. Also included in this package is an "L" bracket (P/N 47-085860-000) that can be used if it is necessary to relocate the Mechanics Remote Stop Box.

*Intentionally Blank Page*

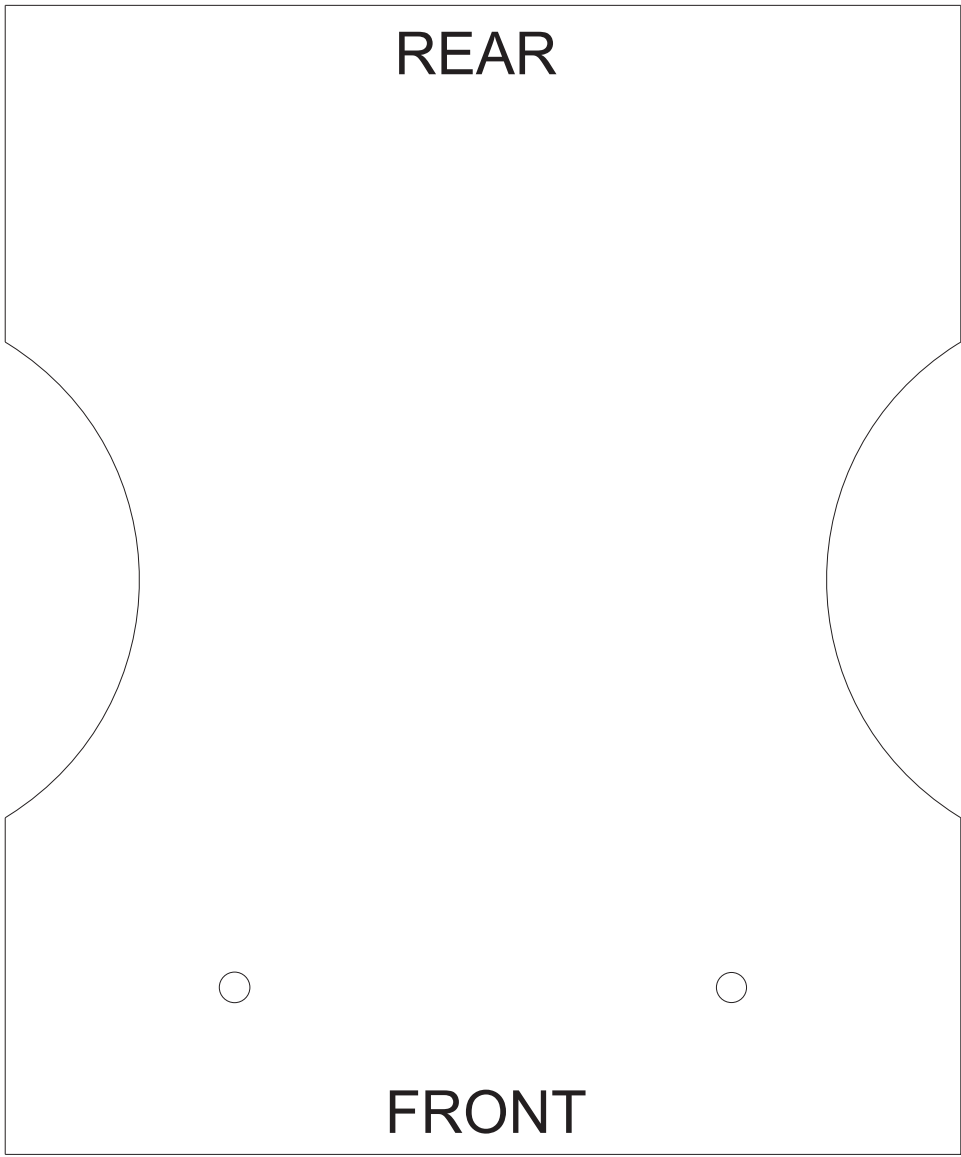

*Template*