

**Model “A/A2” Automatic Pinsetter
 Obsolete “GE” Thermal Overload
 Relay Replacement**

i *NOTE: This external motor overload relay is only required for pinsetters that **DO NOT** have motors with internal overload protection. Motors with internal overload protection (identified by the “RESET” button on the end of the motor) do not require this relay.*

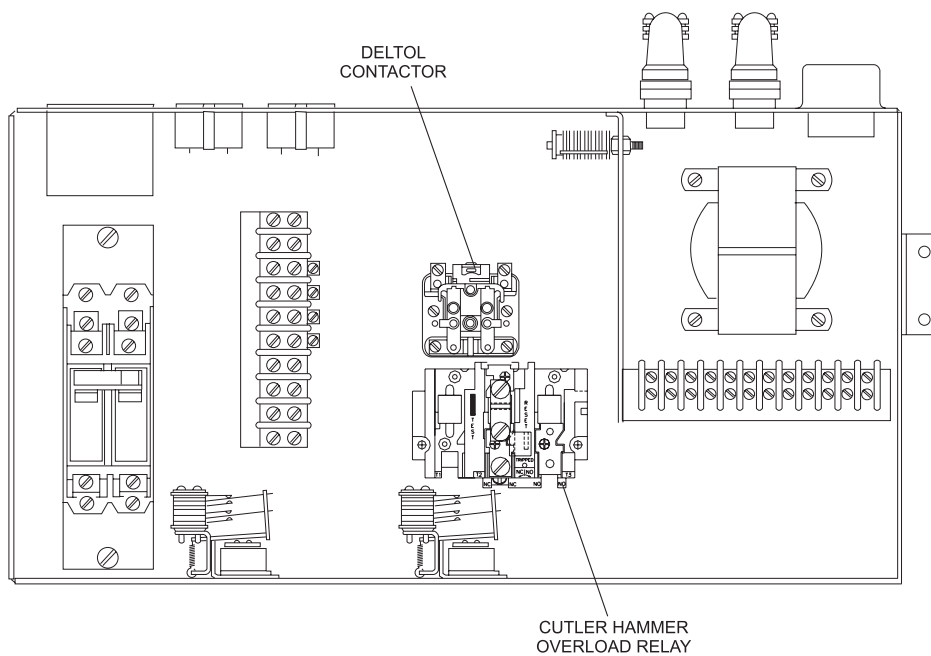

CAUTION! *These instructions are intended for use by a pinsetter mechanic, who must carefully follow the step-by-step instructions for installation of the new contactor and overload relay. The illustration above shows the relative positions the new parts assume when installed according to the following directions.*

Packaging

- (1) 12-860334-000 Kit, Pinsetter Motor Thermal Overload Relay (less heater)
 - (1) 10-679108-000 Motor Overload Relay
 - (1) 10-679001-000 Shield – Fishpaper

TOOLS REQUIRED:

- (1) Heavy Duty Tin Shears
- (1) 3/8” Drill Motor
- (1) 7/32” Drill Bit
- (1) 11/32” Box End Wrench
- (1) Screwdriver with 6” Blade for slotted head screws
- (1) Light Duty Scissors

Parts Required:

Order for kit must specify the Brunswick Part Number of the heater required. Heaters are not included in the kit and must be ordered separately.

- (1) 12-860334-000 Package - Relay, Motor Overload (See Packaging, Page 2)
- * (1) Overload Relay Heater Coil

* (See chart below and select heater on basis of motor current requirement stamped on motor identification tag.)

STANDARD TRIP OVERLOAD RELAY HEATERS			
Brunswick P/N	Maximum Motor Full Load Amps	Cutler Hammer P/N	UPC Number
10-679125-001	4.32A – 4.71A	FH31	78667862980
10-679125-002	4.72A – 5.14A	FH32	78667862983
10-679125-003	5.15A – 5.6A	FH33	78667862986
10-679125-004	5.7A – 6.2A	FH34	78667862989
10-679125-005	6.3A – 6.8A	FH35	78667862992
10-679125-006	6.9A – 7.5A	FH36	78667862995
10-679125-007	7.6A – 8.2A	FH37	78667862998
10-679125-008	8.2A – 9.0A	FH38	78667867000
10-679125-009	9.1A – 9.9A	FH39	78667867003
10-679125-010	10.0A – 10.8A	FH40	78667867006
10-679125-011	10.9A – 11.9A	FH41	78667867009
10-679125-012	12.0A – 13.1A	FH42	78667870012
10-679125-013	13.2A – 14.3A	FH43	78667867015
10-679125-014	14.4A – 15.7A	FH44	78667867018
10-679125-015	15.8A – 17.2A	FH45	78667867021

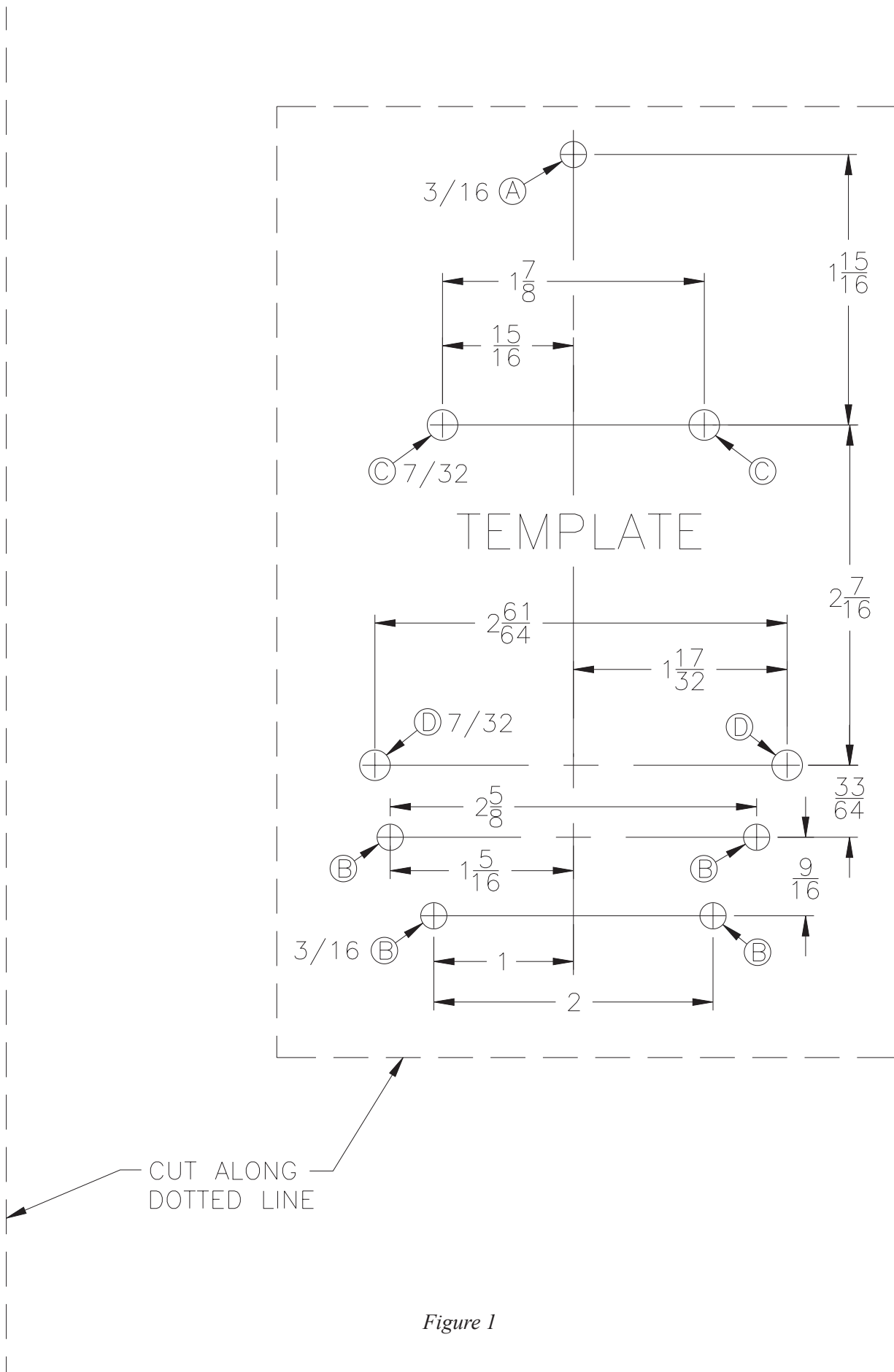

Figure 1

Intentionally Blank Page

Instructions



WARNING! Disconnect the input power connector to electrical control box.

1. Cut page 3 out of this booklet along the dotted lines.
2. Remove the electrical control box cover from the pinsetter. Refer to *Figure 2*.

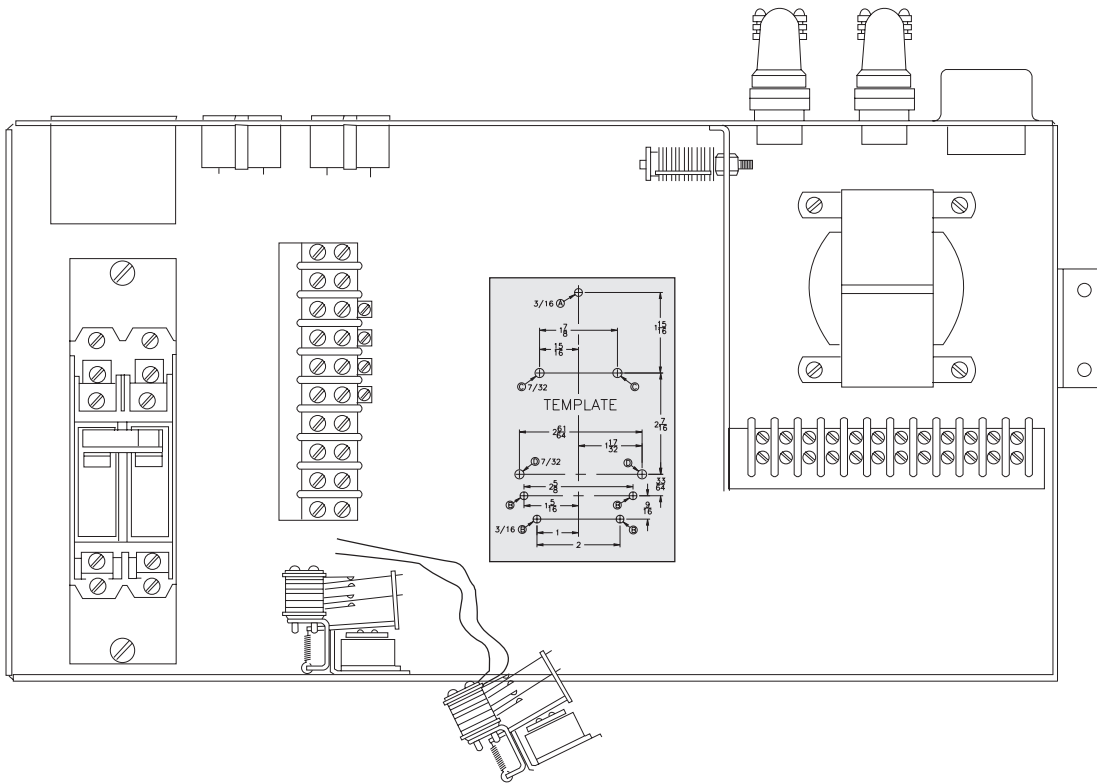

Figure 2

3. Disconnect and mark the wires separately from the terminals of the old “GE” thermal overload relay.
4. Remove the old “GE” thermal overload relay from the box.
5. Remove the screws that hold the time delay unit or recycle relay and motor start relay and pull them out of the box to the limit the wires will allow. Refer to *Figure 2*.
6. Remove the screws that hold the “Deltrol Contactor” and pull it out of the box as far as the wires will allow.
7. Place the drilling template, (*Figure 1*, page 3), into the void left by the old “GE” thermal overload relay and locate holes “A” and “B” on the template with holes “A” and “B” in the box. Hole “A” is the top center hole for the old contactor. Hole “B” is over the motor start relay. Holes “C” are the holes for the “Deltrol” contactor. Hold template in place with masking tape. Refer to *Figure 2*.

8. Center punch holes “D” in preparation for drilling.
9. Drill holes “D” with 7/32” bit.
10. Brush or use a magnet to remove the drilling shavings from the bottom of the box. Put the time delay unit or recycle relay and motor start relay back in place.
11. Reinstall “Deltrol” contactor using holes “C”. Refer to *Figure 3*.

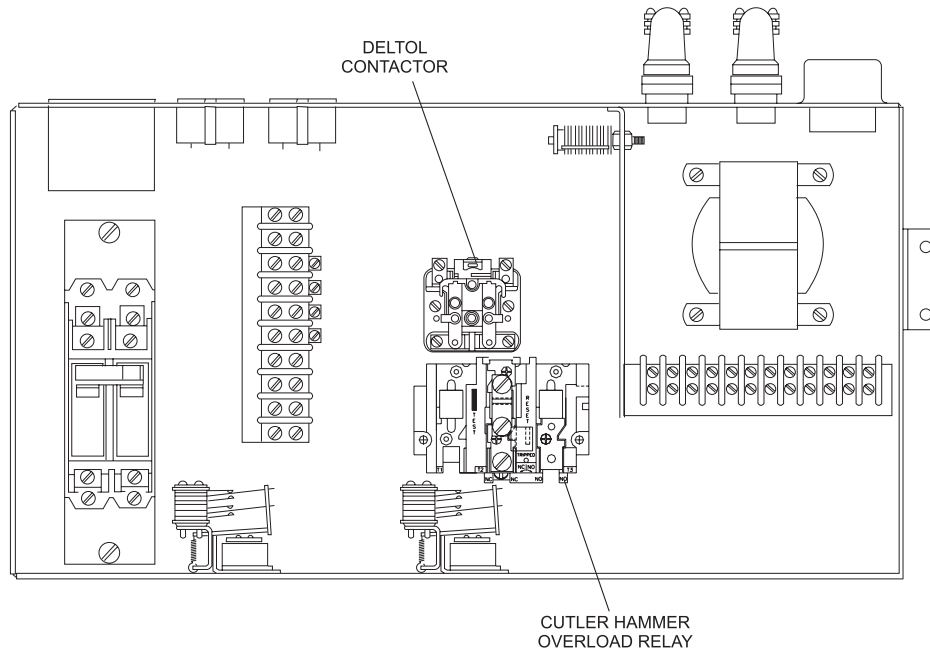

Figure 3

12. Mount the “Cutler Hammer” overload relay using existing hardware. Refer to *Figure 3* for correct position (use holes “D”).

- Connect the wires to the overload relay. Refer to *Figure 4*.

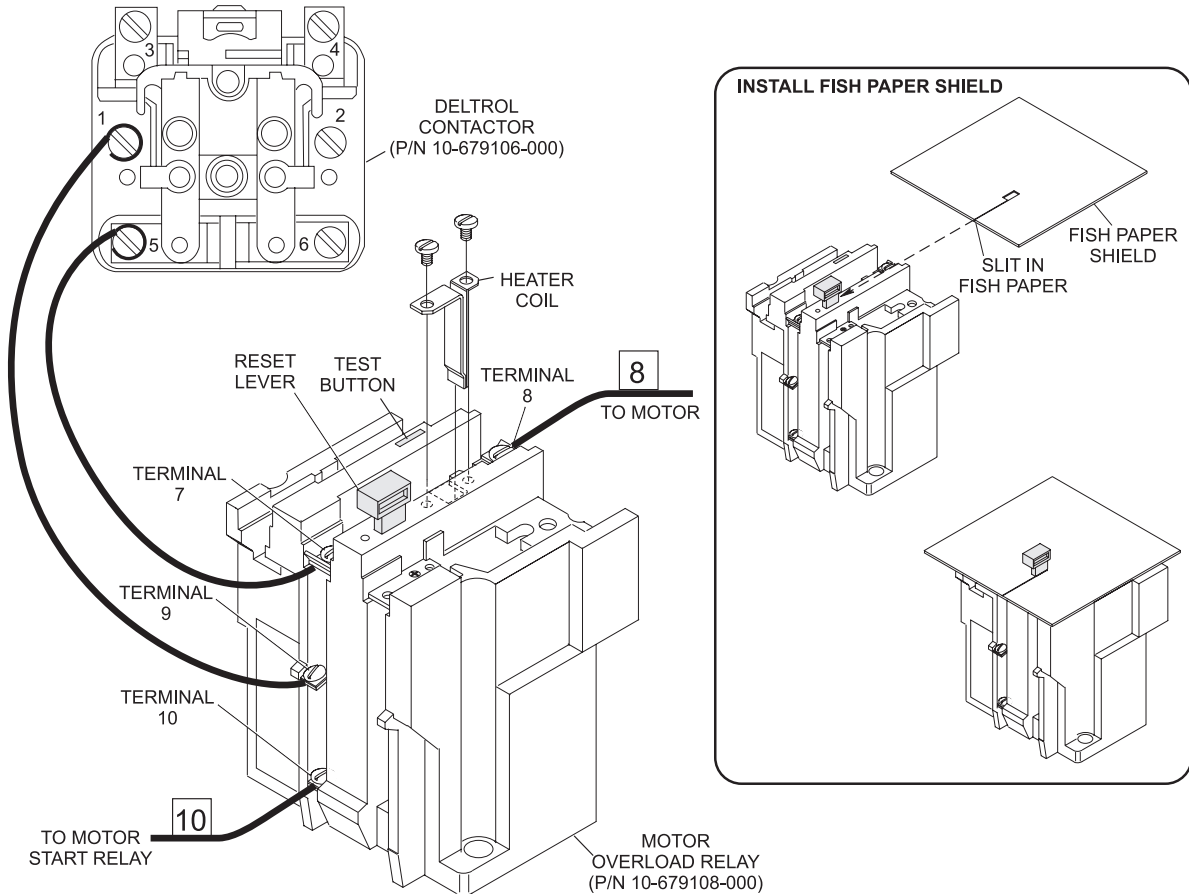

Figure 4

- On page 3 is a table showing heater coil ratings (maximum full load amps), heater identification numbers, and Brunswick part numbers. Select a heater coil that has a rating that matches as closely as possible the maximum motor full load amps stamped on the pinsetter motor identification plate.
- Mount the heater coil. Refer to *Figure 4*.
- Connect power and turn on pinsetter.
- Contactors should be pulled in.

i **NOTE:** It may be necessary to push reset lever on overload relay. Refer to *Figure 4*.

- Check functioning of overload relay by pushing the test button. Contactor should drop out when the test button is pressed. Push the reset button to turn the pinsetter motor on again. Check trip indicator.
- Turn off pinsetter and disconnect power cord.
- Install fish paper shield on reset lever shaft so that the entire top of the relay is covered. Trim if needed. Refer to *Figure 4*.

21. Before replacing the pinsetter electrical box cover, it will be necessary to make a modification. If the cover has a reset button and spring, it will be necessary to remove it by drilling out the rivets. The new relay's reset switch will stick through the hole in the cover. If there is no reset button, it will be necessary to cut a hole in the electrical box cover. Refer to *Figure 5*.

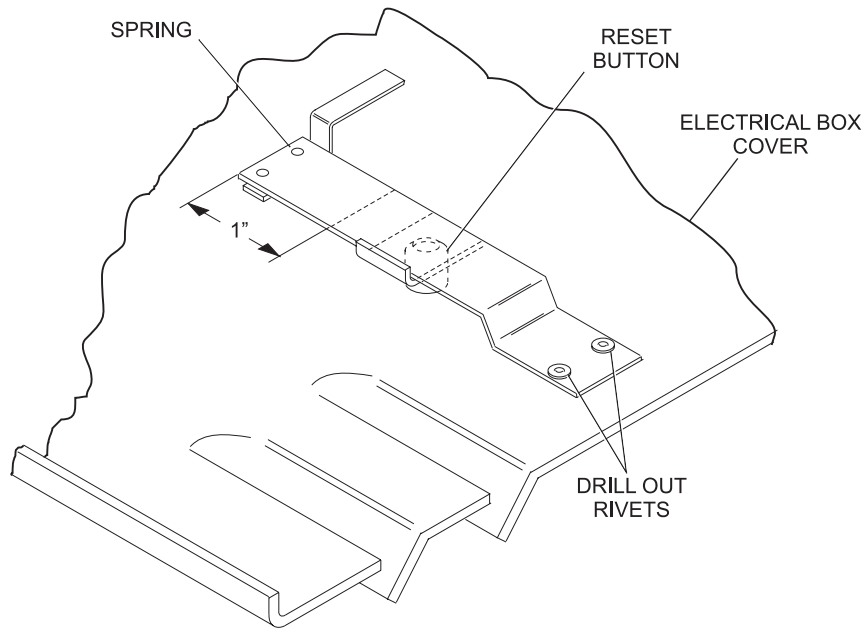

Figure 5

22. Slide the cover onto the electrical box and visually check to insure that the relay's reset button does not bind and works freely. It will be necessary to enlarge the hole in the cover to approximately 3/4" diameter. Refer to *Figure 5*.