

Pinball Wizard/Bankshot Reduced Pinching Vertical Support Upgrade for Existing Centers

These instructions will provide you with the step by step process to replace the first two existing vertical supports in the first section of gutter with new reduced pinching vertical supports. This will greatly reduce the likelihood of pinching or injury.

This process requires removal of the first gutter section. You may want to install only one lane at first, this will give you a guide line as to how much time will be required to do the change out. After the first lane is installed, there is some efficiency to doing multiple lanes at once.

Packaging

Supplied Per Lane

- 4 ea. 84-200546-000 Reduced Pinching Vertical Support
- 4 ea. 11-537050-000 E-Clip

Optional Items - Not supplied

- 84-200472-000 Brunswick E-Clip Installation Tool (Roto Clip, Model A-160)

Installation

1. Raise the rails on the lane to be upgraded. For centers with Automatic Bankshot/Pinball Wizard, disconnect the actuator arm from the rail. This is done by removing the E-clip and pin. Refer to *Figure 1*.

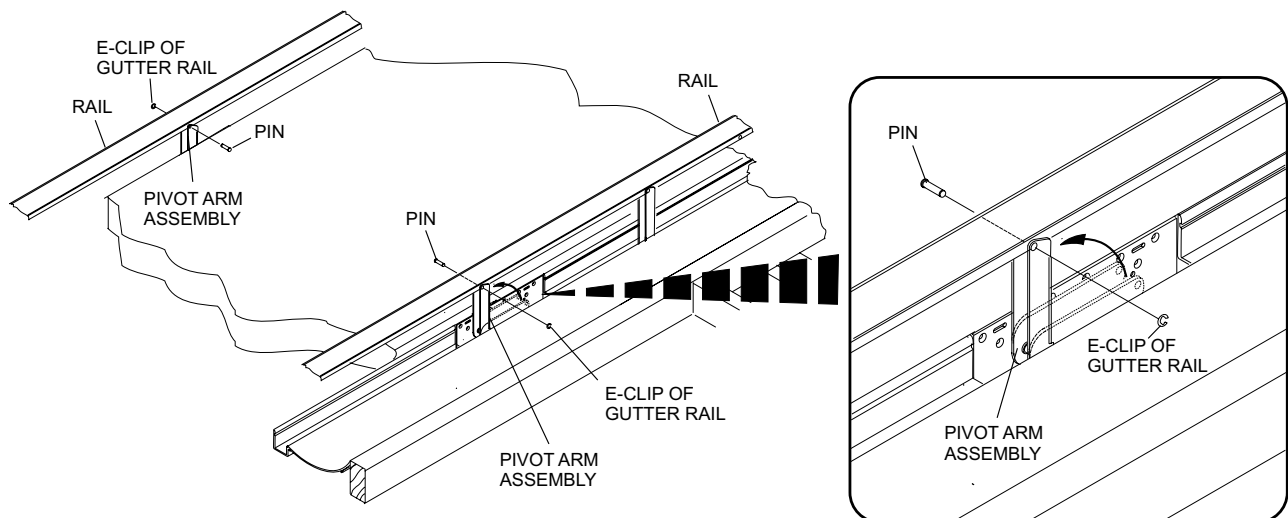
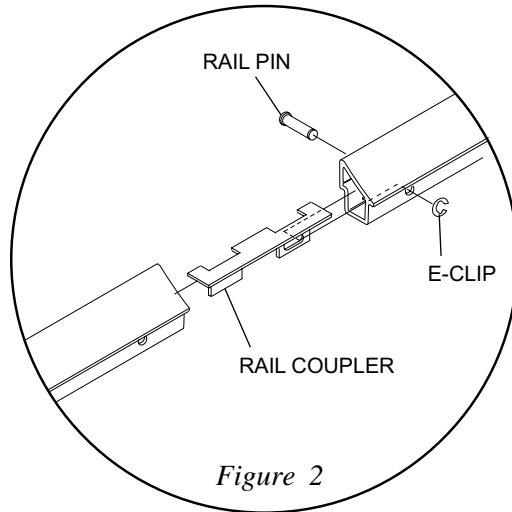
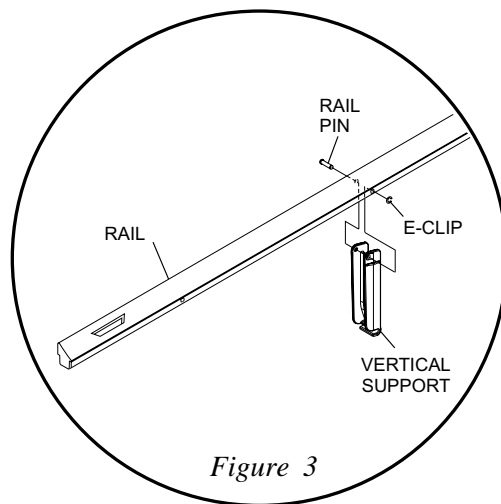

Figure 1

2. Separate the first rail from the second rail, by removing the E-clip and pin from the rail joint. Retain for future use. Refer to *Figure 2*.



3. Remove the first two vertical supports from the first rail. Set aside E-clips, bushings, washers and pins to be reused later. Refer to *Figure 3*.



- At the foul line, remove the screws securing the header block to the gutter and remove the header block and cosmetic strip. Set aside for reinstallation later. Refer to *Figure 4*.

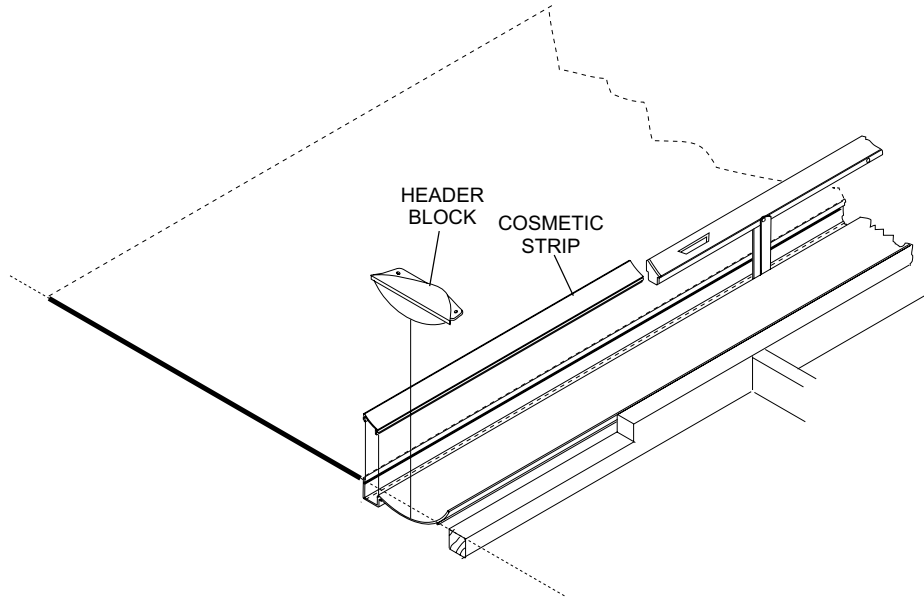

Figure 4

- Remove all screws securing the first gutter section and remove that section of gutter.



NOTE:

*It may be necessary to remove the ball return and division capping to allow the gutter to be removed. Refer to *Figure 5*.*

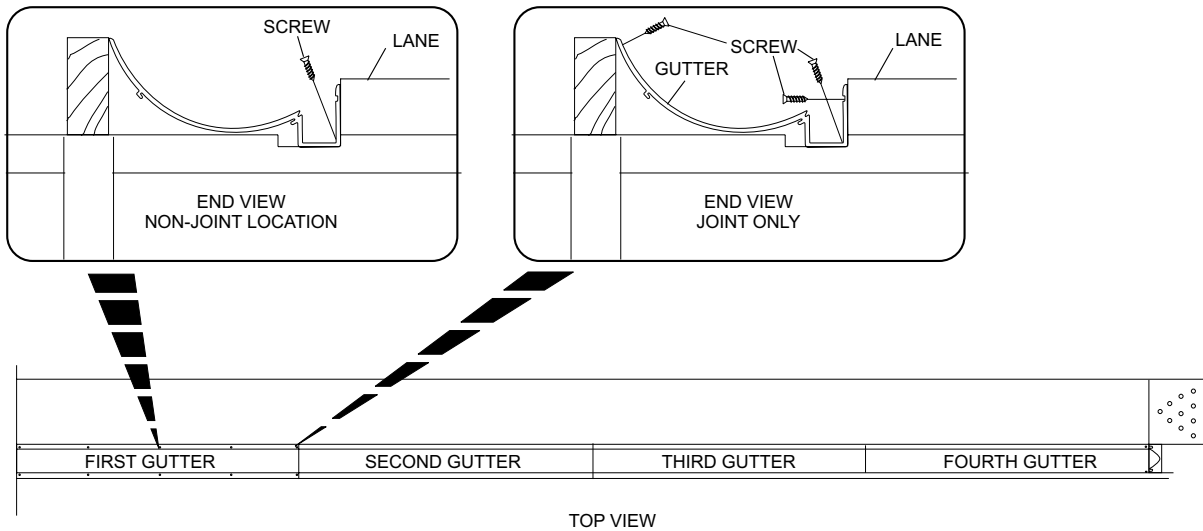

Figure 5

- Turn the gutter over and remove the first two E-clips and pins from the gutter. Set aside for reinstallation in the next step. Refer to *Figure 6*.

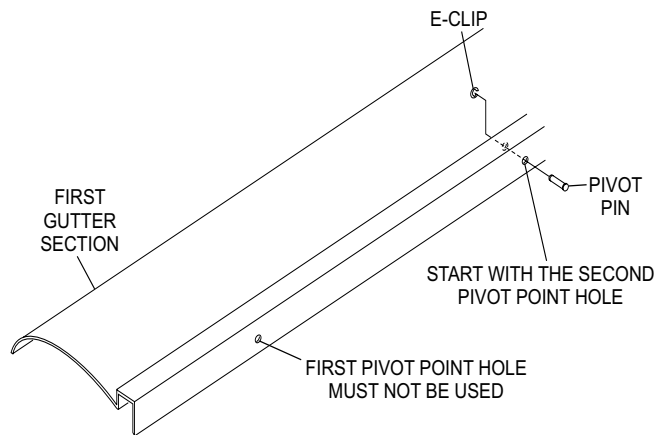

Figure 6

- Turn the gutter upright again. Starting at the foul line side of the gutter, place a new reduced pinching vertical support into the gutter at the *second* pivot point with the pad end of the upright toward the pinsetter.

i *NOTE: The metal vertical supports are universal, there are no left and rights.*

i *IMPORTANT!:*

The first pivot point must not be used. The first rail must end at the coupling between the first gutter section and the second gutter section. Overlapping the second rail with the first gutter section can cause binding.

- Insert the pin through the gutter and halfway through the wide end of the vertical support. Slide the **rubber bushing** onto the pin and continue to push pin through the upright and gutter. Refer to *Figure 7*.

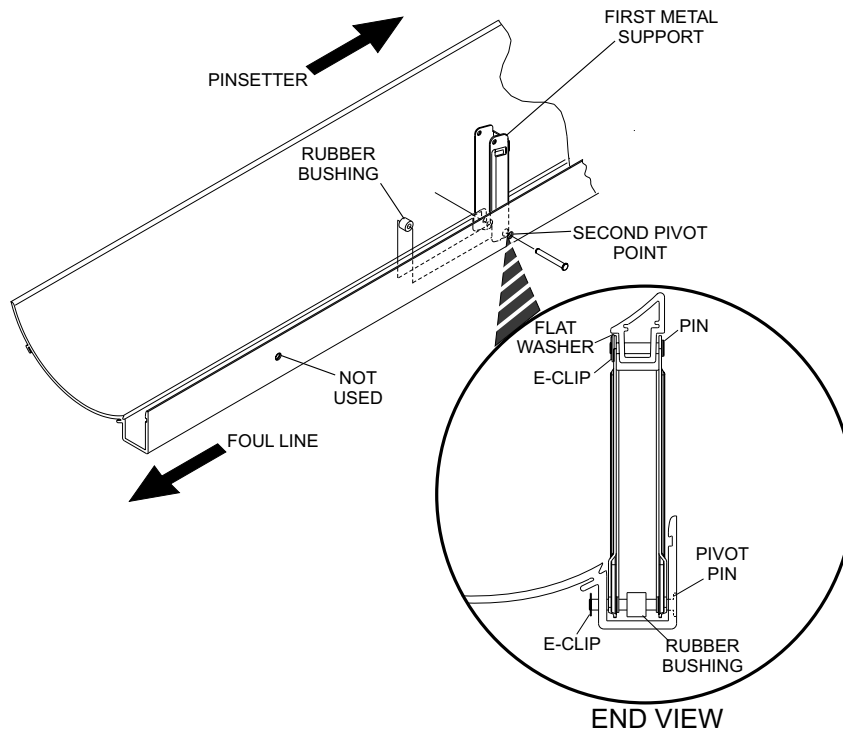

Figure 7

9. Repeat Step 8 for the second vertical support.
10. Turn the gutter over and reinstall the e-clips on all pins. Verify that all E-clips are fully seated in the groove of the pin. Refer to Figure 8. Use of the optional E-clip installation tool will assure clips are installed properly and quickly.

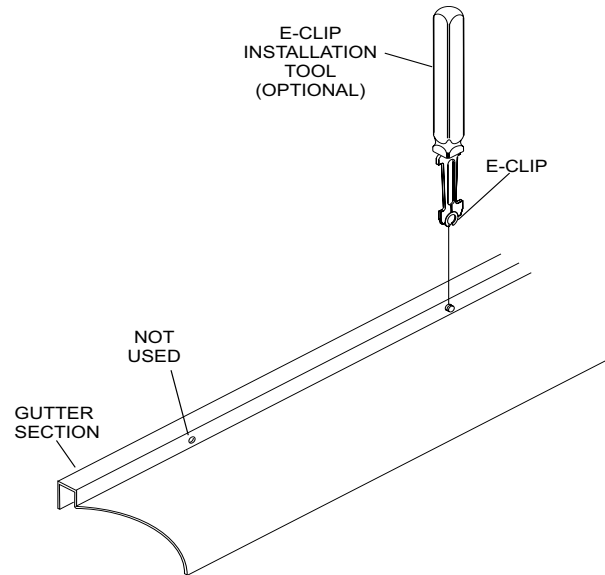

Figure 8

11. Place the rail into the gutter channel, raise a vertical support and insert the pin from the **lane side** of the rail through the vertical support and rail. Place the **flat washer** onto the pin and reinstall the E-clip. Repeat for the second vertical support. Refer to Figure 9.

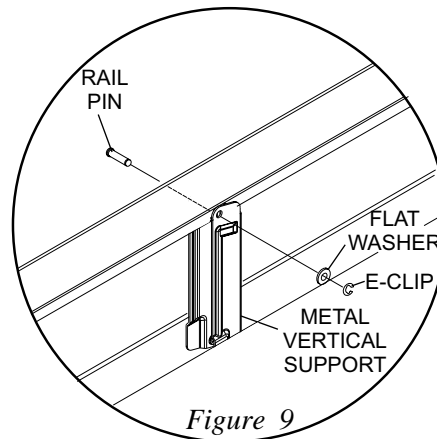

Figure 9

12. Make sure the gutter coupler plate is installed in the second gutter section. Refer to *Figure 10*.

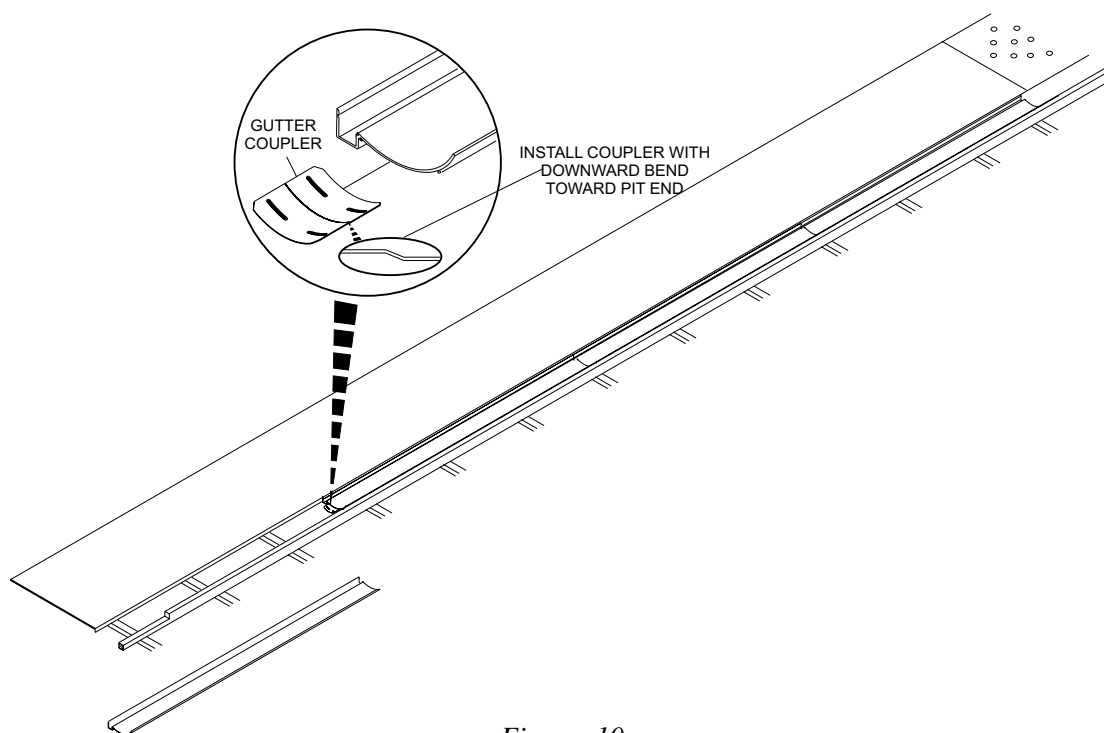

Figure 10

13. Reinstall the first gutter section sliding it onto the coupler plates. Secure the gutter to the foundation using the original screws. Refer to *Figure 5*.
14. Reinstall the cosmetic strip and transition block at the foul line. Refer to *Figure 4*.
15. If the lane is equipped with a Pinball Wizard motor, reconnect the actuator arm to the rail with a pin and E-clip. Refer to *Figure 1*.
16. Reconnect the first rail to the second rail with a pin and an E-clip. Refer to *Figure 2*.
17. Reinstall any capping that has been removed.
18. Test the bumpers by raising and lowering the rails a few times. Check for any binding and repair as necessary.



CAUTION!

If raising and lowering rails manually, be sure to follow proper procedure as previously outlined in Brunswick Service Bulletins SB05-2 & SB05-6. These can be found online at www.brunswickbowling.com/service_bulletins/