

Pinball Wizard/Bankshot Vertical Support Upgrade for Existing Centers

These instructions will provide you with the step by step process of replacing the first seven existing supports in the first section of gutter with metal supports, and as required, Lexan supports the rest of the way down the lane. This will greatly reduce the breakage of vertical supports throughout your center.

This process requires inspecting and identifying all existing vertical supports and removal of the first gutter section. You may want to install only one lane at first, this will give you a guide line as to how much time will be required to do the change out. After the first lane is installed, there is some efficiency to doing multiple lanes at once.

Packaging

Supplied Per Lane Pair

1	84-860695-000	Vertical Support Metal Upgrade Kit
28	84-200490-000	Metal Vertical Support
30	84-200487-000	Rubber Bushing
30	11-190509-000	Flat Washer
5	11-537050-000	E-Clip

Optional Items

84-200454-001	Right Hand Lexan Vertical Support
84-200454-002	Left Hand Lexan Vertical Support
84-200472-000	Brunswick E-Clip Installation Tool (Roto Clip, Model A-160)

Installation

1. Raise the rails on the lane to be upgraded. For centers with Pinball Wizard disconnect the motor drive arm from the rail. This is done by removing the e-clip and pin. Refer to *Figure 1*.

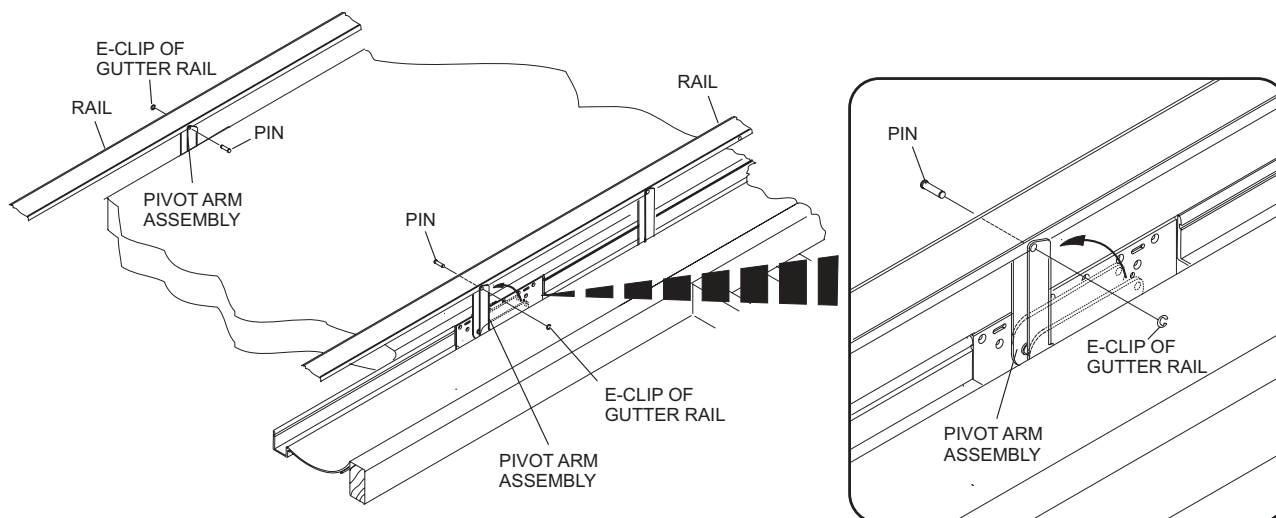

Figure 1

IMPORTANT: Starting at the foul line using a plastic faced hammer, tap each vertical support on the foul line side to disengage the support from pivot pin and lay all **four** rails over onto the lane. Refer to Figure 2.

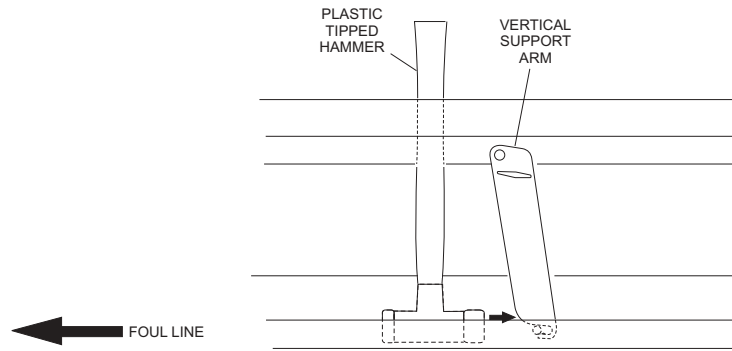

Figure 2

2. Separate the first rail from the second rail, by removing the e-clip and pin from the rail joint. Refer to Figure 3.

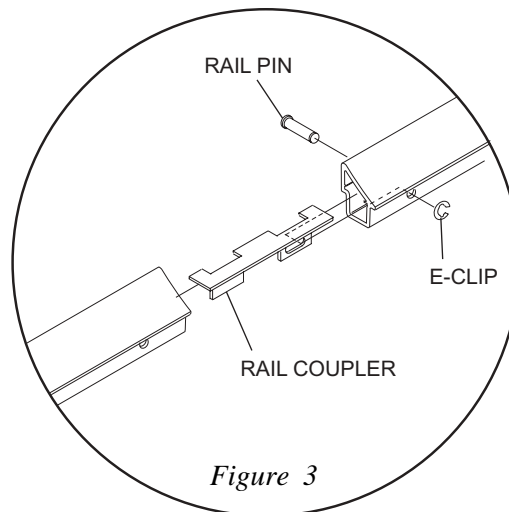

Figure 3

3. Remove all seven vertical supports from the first rail. Set aside e-clips and pins to be reused later. Refer to Figure 4.

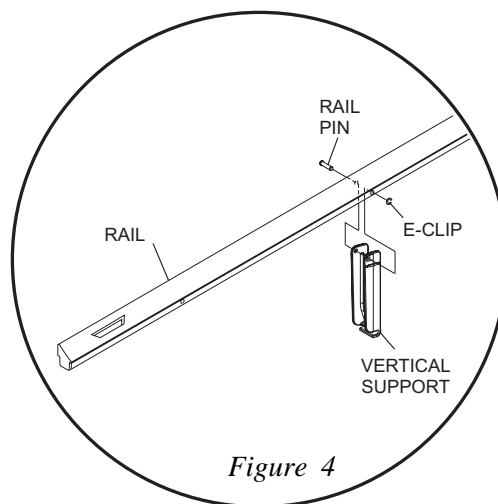

Figure 4

- Identify the vertical support with the clock code (1 & 2 Lexan, 3 & 4 ABS). Destroy all ABS vertical supports by breaking in half and discarding. Refer to *Figure 5*.

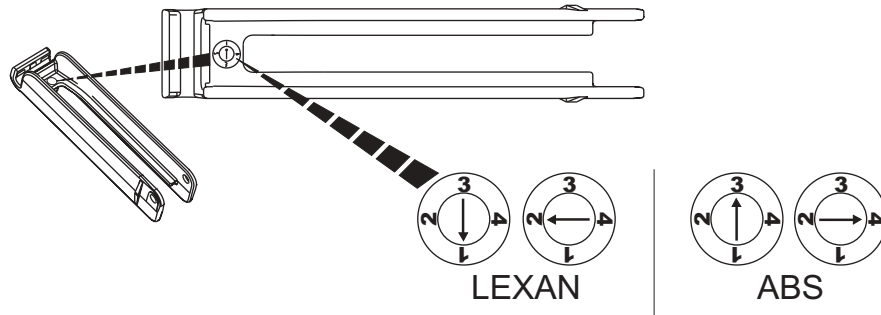

Figure 5

- Inspect all Lexan vertical supports for cracks or breakage. Discard the damaged ones and set aside the rest to be reused later.
- Identify the rest of the vertical supports on the down lane rails as in steps 4 & 5. Remove and destroy all ABS uprights and replace with Lexan. Replace any damaged Lexan vertical supports.
- At the foul line, remove the screws securing the header block to the gutter and remove the header block and cosmetic strip. Set aside for reinstallation later. Refer to *Figure 6*.

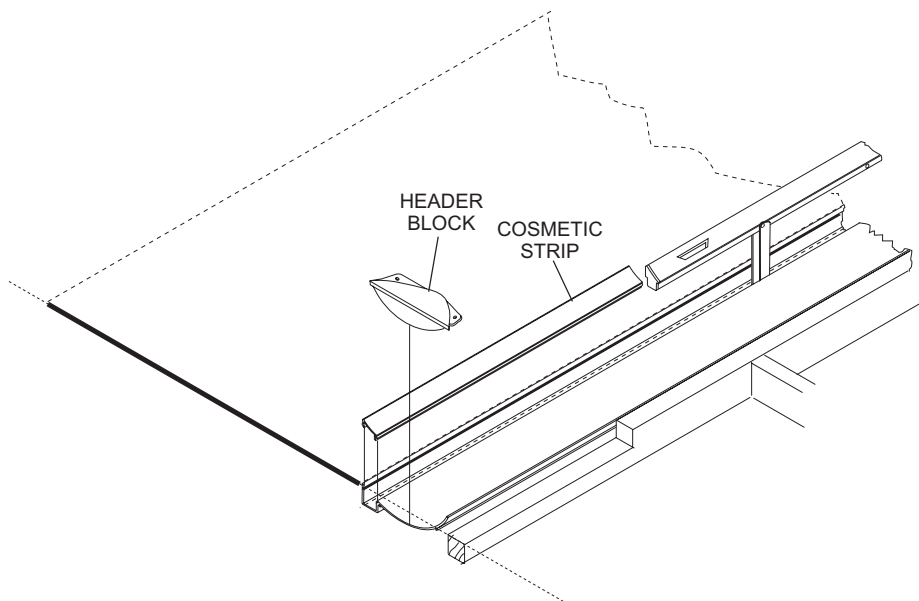

Figure 6

- Remove all screws securing the first gutter section and remove that section of gutter.

NOTE: It may be necessary to remove the ball return and division capping to allow the gutter to be removed. Refer to Figure 7.

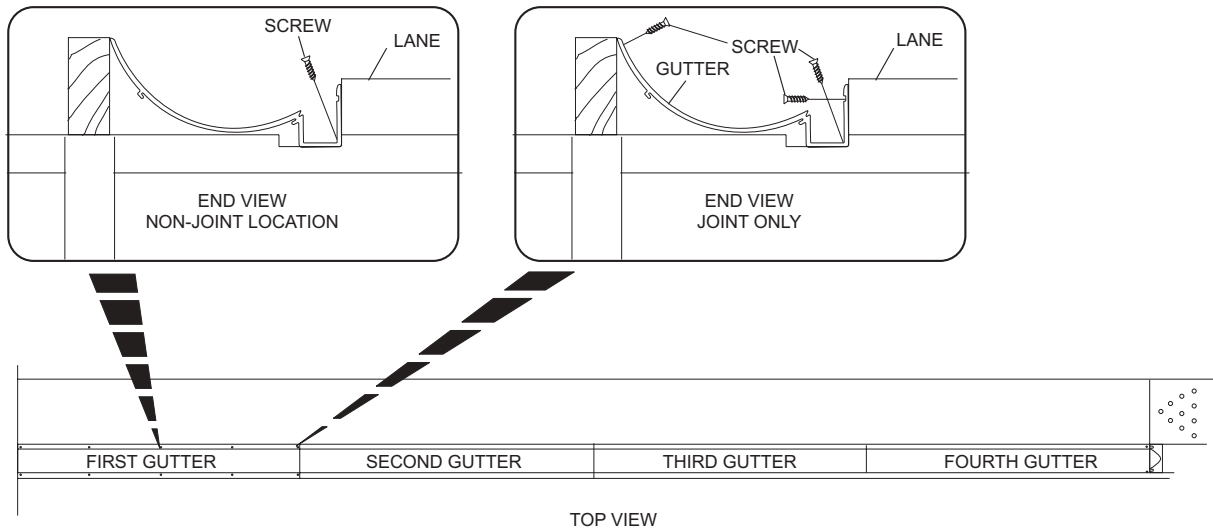

Figure 7

9. Turn the gutter over and remove all the e-clips and pins from the gutter. Set aside for reinstallation in the next step. Refer to Figure 8.

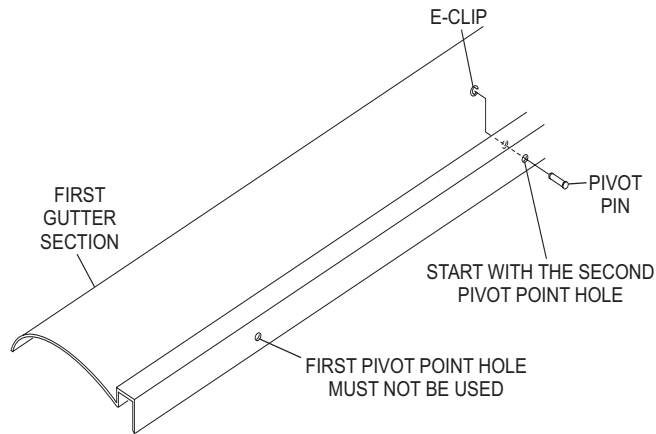

Figure 8

10. Turn the gutter upright again. Starting at the foul line side of the gutter, place a metal vertical support (package 84-860695-000) into the gutter at the **second** pivot point with the pad end of the upright toward the pinsetter.

NOTE: The metal vertical supports are universal, there are no left and rights.

IMPORTANT: The first pivot point must not be used. The seven metal supports and the first rail must end at the coupling between the first gutter section and the second gutter section. Overlapping the second rail with the first gutter section can cause binding.

11. Insert the pin through the gutter and halfway through the wide end of the vertical support. Slide the **rubber bushing** onto the pin and continue to push pin through the upright and gutter. Refer to *Figure 9*.

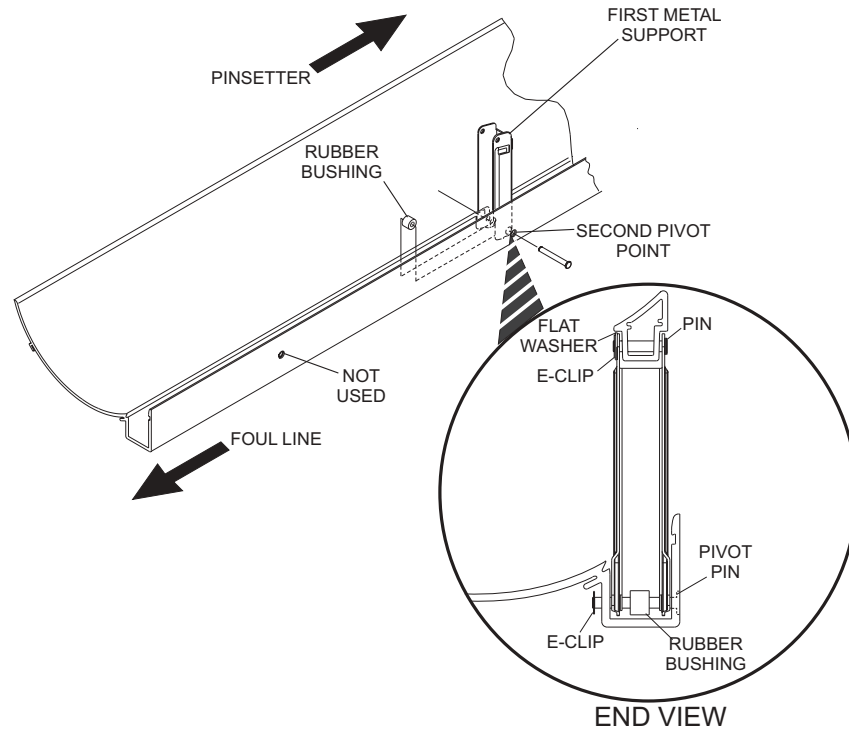

Figure 9

12. Repeat Step 11 for the next six vertical supports.
13. Turn the gutter over and reinstall the e-clips on all seven pins. Verify that all E-clips are fully seated in the groove of the pin. Refer to *Figure 10*.

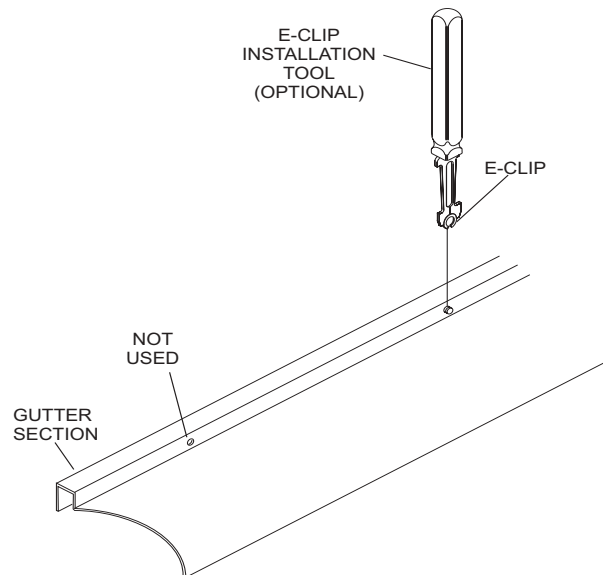
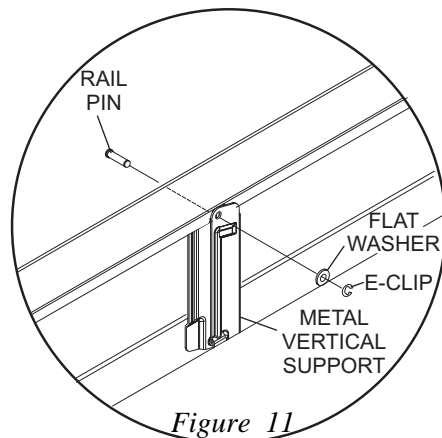
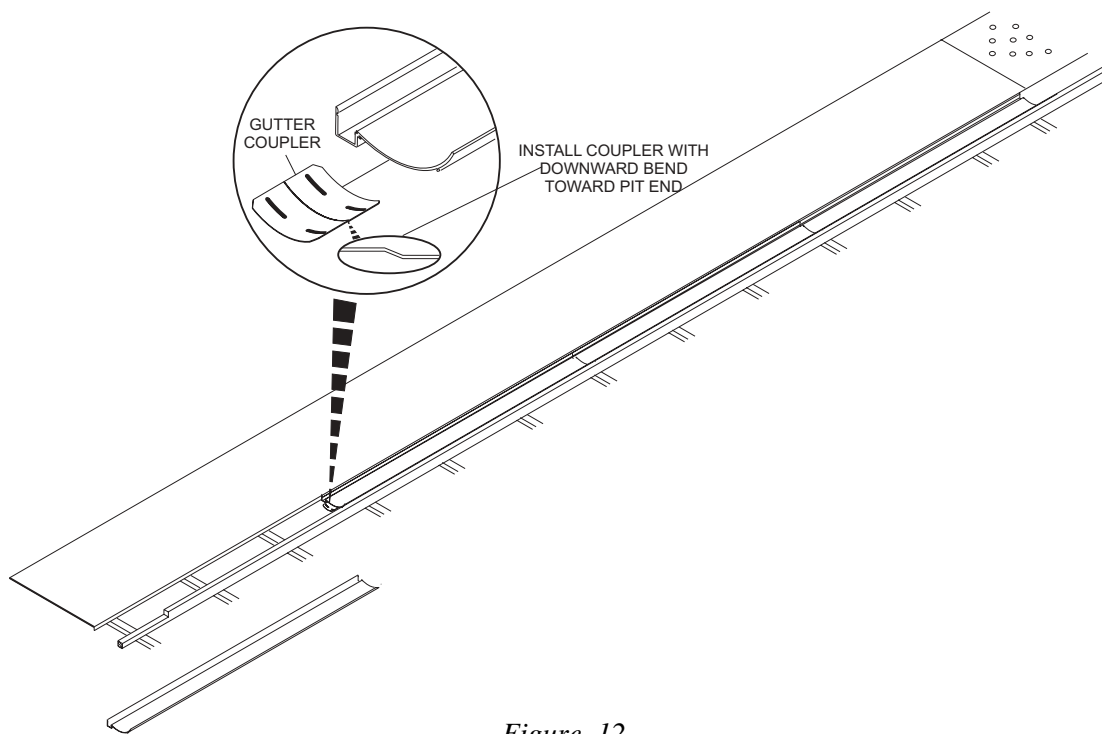

Figure 10

- Place the rail into the gutter channel, raise an upright and insert the pin from the **lane side** of the rail through the upright and rail. Place a **flat washer** from the kit onto the pin and reinstall the e-clip. Repeat for the remainder of the uprights. Refer to *Figure 11*.



- Make sure the gutter coupler plate is installed in the second gutter section. Refer to *Figure 12*.



- Reinstall the first gutter section sliding it onto the coupler plates. Secure the gutter to the foundation using the original screws. Refer to *Figure 7*.
- Reinstall the cosmetic strip and transition block at the foul line. Refer to *Figure 6*.

18. Reinstall the down lane rails using a plastic faced hammer, firmly tap each vertical support onto the pivot pin in the gutter. Refer to *Figure 13*.

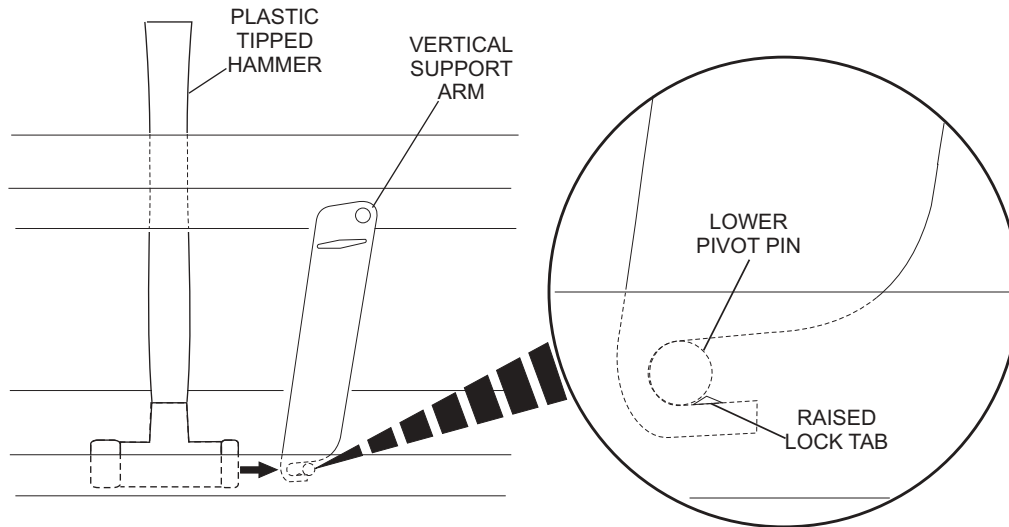

Figure 13

19. If the lane is equipped with a Pinball Wizard motor, reconnect the motor drive arm to the rail with a pin and e-clip. Refer to *Figure 1*.
20. Reconnect the first rail to the second rail with a pin and an e-clip. Refer to *Figure 3*.
21. Reinstall any capping that has been removed.
22. Test the bumpers by raising and lowering the rails a few times. Check for any binding and repair as necessary.