



*Pre-Installation Manual*

---

# **Landscape Video Masking Unit**

November 2010 / 10-095400-049  
1110-17

**Brunswick**<sup>®</sup>   
CUSTOMER SERVICE  
A tradition in excellence.

## **Lanescape Video Masking Unit Pre-Installation Manual**

© November 2010 by the Brunswick Bowling and Billiards Corporation. All rights reserved.

Lanescape Video Masking Unit is a registered trademark of the Brunswick Bowling and Billiards Corporation.

Reorder Part No. 10-095400-049

Notice: If available, updates to this manual can be found on-line at [www.brunswickbowling.com](http://www.brunswickbowling.com).

Confidential proprietary information. All information contained in this document is subject to change without notice.

Brunswick Bowling & Billiards Corporation  
525 West Laketon Avenue  
P.O. Box 329  
Muskegon, MI 49443-0329  
U.S.A.

231.725.3300

---

## SAFETY

Throughout this publication, “Warnings”, and “Cautions” (accompanied by one of the International HAZARD Symbols) are used to alert the mechanic to special instructions concerning a particular service or operation that may be hazardous if performed incorrectly or carelessly. They are defined below. **OBSERVE AND READ THEM CAREFULLY!**

These “Safety Alerts” alone cannot eliminate the hazards that they signal. Strict compliance to these special instructions when performing the service, plus training and “Common Sense” operation are major accident prevention measures.

 **NOTE or IMPORTANT!:** Will designate significant informational notes.



**WARNING!**  
Will designate a mechanical or nonelectrical alert which could potentially cause personal injury or death.



**WARNING!**  
Will designate electrical alerts which could potentially cause personal injury or death.



**CAUTION!**  
Will designate an alert which could potentially cause product damage.



Will designate grounding alerts.

---

## SAFETY NOTICE TO USERS OF THIS MANUAL

This manual has been written and published by the Service Department of Brunswick Bowling and Billiards to aid the reader when servicing or installing the products described.

It is assumed that these personnel are familiar with, and have been trained in, the servicing or installation procedures of these products, which includes the use of common mechanic's hand tools and any special Brunswick or recommended tools from other suppliers.

We could not possibly know of and advise the reader of all conceivable procedures by which a service might be performed and of the possible hazards and/or results of each method. We have not attempted any such wide evaluation. Therefore, anyone who uses a service procedure and/or tool, which is not recommended by Brunswick, must first completely satisfy himself that neither his nor the products safety will be endangered by the service procedure selected.

All information, illustrations and specifications contained in this manual are based on the latest product information available at the time of publication.

It should be kept in mind, while working on the product, that the electrical system is capable of violent and damaging short circuits or severe electrical shocks. When performing any work where electrical terminals could possibly be grounded or touched by the mechanic, the power to the product should be disconnected prior to servicing and remain disconnected until servicing is complete.

---

## Table of Contents

<i>Important!</i> .....	6
<i>Warning</i> .....	6
<i>Grounding Conductor - NEC 384-27</i> .....	6
<i>Extended Power Outage</i> .....	6
<i>Atmospheric Conditions</i> .....	6
<i>Conduit and Low Voltage Cable Specifications</i> .....	7
<i>Electrical Quick Reference Checklist</i> .....	8
<i>Projector Electrical Specifications</i> .....	9
<i>Standard Projector</i> .....	9
<i>High Output Projector</i> .....	9
<i>Projector Electrical Specifications</i> .....	10
<i>Customer Responsibility - Ceiling/Cable Projection Screen</i> .....	11
<i>Customer Responsibility - Projection Power Connections</i> .....	12
<i>Customer Responsibility - Standard Projector - Closed Ceiling</i> .....	13
<i>Customer Responsibility for Projector Installation - Closed Ceiling</i> .....	13
<i>Customer Responsibility - High Output Projector - Closed Ceiling</i> .....	14
<i>Customer Responsibility for Projector Installation - Closed Ceiling</i> .....	14
<i>Customer Responsibility - Projector - Closed Ceiling</i> .....	15
<i>Customer Responsibility - Standard Projector - Open Ceiling</i> .....	16
<i>Customer Responsibility for Projector Installation - Open Ceiling</i> .....	16
<i>Customer Responsibility - High Output Projector - Open Ceiling</i> .....	17
<i>Customer Responsibility for Projector Installation - Open Ceiling</i> .....	17
<i>Customer Responsibility - Projector - Open Ceiling</i> .....	18
<i>Multiple Screen Layout for 12 Lanes Standard Projectors</i> .....	19
<i>Suggested Light Planning</i> .....	20
<i>Operation</i> .....	20

# *Important!*

---

This document contains information on electrical, installation, conduit, and lighting for the Brunswick Lanescape Video Masking Unit. It also contains the necessary information for the preparation of a site conforming to Brunswick specifications. Any deviation from these specifications could cause problems to your equipment that may be difficult to detect and/or correct. If you have questions regarding this document, call the Brunswick Customer Response Center at 1-800-YES-BOWL, or 231-725-4966, fax 231-725-4667, e-mail [crc.support@brunbowl.com](mailto:crc.support@brunbowl.com), 24 hours a day, 7 days a week.

## **Warning**

This equipment generates, uses, and can radiate radio frequency energy or interfere with radio communications if not installed and used in accordance with the pre-installation manual. Operation of this equipment in a residential area is likely to cause interference in which case the user, at his own expense, will be required to take whatever measures may be required to correct the interference.

## **Grounding Conductor - NEC 384-27**

The grounding conductor shall be permitted to pass through one or more subpanels without connection to the panel board grounding terminal as permitted by Section 384-27 Exception, so as to terminate directly at the applicable derived system or service grounding terminal.

## **Extended Power Outage**

The circuit breakers (electronic subpanel) must be clearly identified and should be left on at all times under normal operation. If power is to be out for an extended period of time, it is recommended that circuit breakers to the electronic equipment be turned off. When power is restored, transient voltages could be induced into the equipment if circuit breakers are not turned off.

## **Atmospheric Conditions**

It is important that the climate control is maintained throughout the center. Indoor humidity is a large factor in lane conditions as well reducing static electricity. A relative level of 45% must be maintained to obtain optimum characteristics and performance from all equipment. A minimum of 35% and a maximum of 50% is possible if the temperature is controlled and constant.

# Conduit and Low Voltage Cable Specifications

---

When routing the conduit from the Brunswick Lanescape Video Masking Unit to the Control Desk, extra care must be exercised to prevent placement near a noisy electrical environment.

1. The cables need to be installed in conduit **only when local codes require it**.
2. Keeping the conduit routing to a minimum is preferred, however, keep in mind that routing them away from a noisy electrical environment is most important.
3. If conduit is required, only telephone or communication cables may be routed in the same conduit. **Do not route them in conduit with high voltage power cables.**
4. **Do not** lay the interconnecting cables or conduit raceways on top of, or close to fluorescent light fixtures. Route them as far from the fixtures as possible.
5. Keep cables as far away as possible from motors, compressors, and high voltage power cables. Do not lay them next to or closely parallel to existing high voltage electrical cables. When there is any doubt, contact your local representative, or contact the Brunswick Customer Response Center at 1-800-YES-BOWL or 231-725-4966, fax 231-725-4667, e-mail [crc.support@brunbowl.com](mailto:crc.support@brunbowl.com), 24 hours a day, 7 days a week.

**i** **NOTE:** Do not use plumbing PVC pipe for low voltage cable runs. **Electrical PVC** must be used for all conduit runs.

# Electrical Quick Reference Checklist

---

- FAILURE to COMPLY** with the *Electrical Quick Reference and Pre-Installation Manual* specification will void **ALL** warranties. All electrical work must be completed before the Brunswick Field Engineer arrives on-site.
- EARTH GROUND** conductor **MUST BE** a minimum of **#6 AWG** wire or larger.
- Greenfield or conduit **CANNOT** be used as the **EQUIPMENT GROUND** conductor for the system.
- All branch circuit runs **OVER 200 FEET** from the electronics subpanel must be **#10 AWG** wire or larger.
- Class-A **CERTIFIED** ground is recommended and should be measured at main service.

# Projector Electrical Specifications

Installation of projection screens must be complete before projectors can be installed.

## Standard Projector

Electrical Information										
Volts	Hertz	AC/DC	Phase	Amps Per Unit	Size	Watts	Weight	Lumens	Branch Circuit	Customer Responsibility
100-130 200-240	50/60	AC	1	3.0@120V 1.5@240V	L=13.4" W=13.0" H=4.7"	375	12.0 Lbs.	3500	2 Wires + Ground	Install circuit with 120V no more than five per 20 Amp circuit.  Install circuit with 230V no more than eight per 16 Amp circuit.

## High Output Projector

Electrical Information										
Volts	Hertz	AC/DC	Phase	Amps Per Unit	Size	Watts	Weight	Lumens	Branch Circuit	Customer Responsibility
100-130 200-240	50/60	AC	1	5.5@120V 2.75@240V	L=19.88" W=15.16" H=8.23"	655	36.5 Lbs.	4500	2 Wires + Ground	Install circuit with 120V no more than three per 20 Amp circuit.  Install circuit with 230V no more than four per 16 Amp circuit.

**i** NOTE: Customer is responsible for all video cabling and video equipment connected to projector.

# Projection Screen Electrical Specifications

Electrical Information								
Volts	Hertz	AC/DC	Phase	Amps Per Unit	Watts	Weight	Branch Circuit	Customer Responsibility
100-130 200-240	50/60	AC	1	1.1@120V .55@230V	800	55/ Lbs.	2 Wires + Ground	<p>Install circuit with 120V no more than eleven per 20 Amp circuit.</p> <p>Install circuit with 230V no more than twenty per 16 Amp circuit</p>

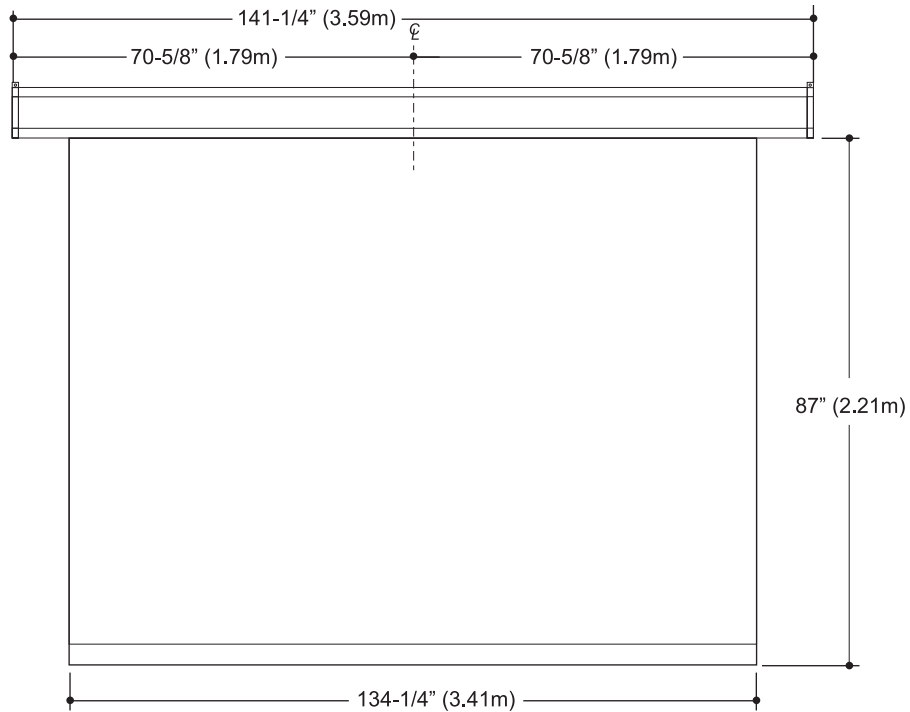

# Customer Responsibility - Ceiling/Cable Projection Screen

## Customer Responsibility for Projection Screen Installation

1. Customer is responsible for providing support structure to which the aircraft cables attach, usually a metal bar or wood beam, that will support the weight load of the projection screen.
2. The support should be located 1 - 2 feet (305mm - 610mm) above the ceiling and 10 - 12 inches (254mm - 305mm) from the masking unit toward the foul line. Refer to the graphic below.

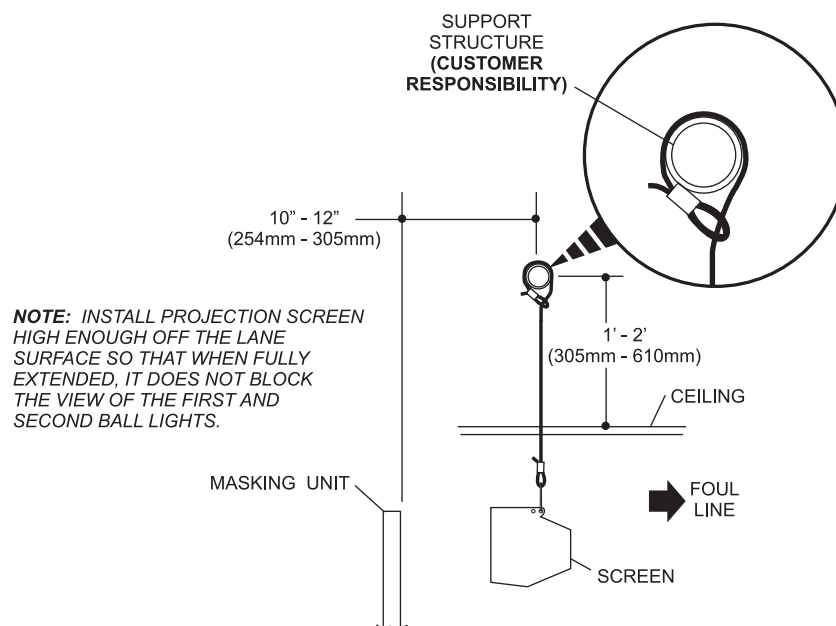

3. The length of the support structure should be longer than the projection screen. Refer to Projection Screen graphic on the previous page. The center line of the support structure should be the same as the center line of the projection screen.

# Customer Responsibility - Projection Screen Power Connections

The power cable and connections of the of the projection screen, projection screen controller and the main 120VAC or 230VAC power is the **responsibility of the customer**.

**i** *NOTE: The power cable for the projection screen is required to be installed to the projection screen by the customer before installation of the projection screen can begin.*

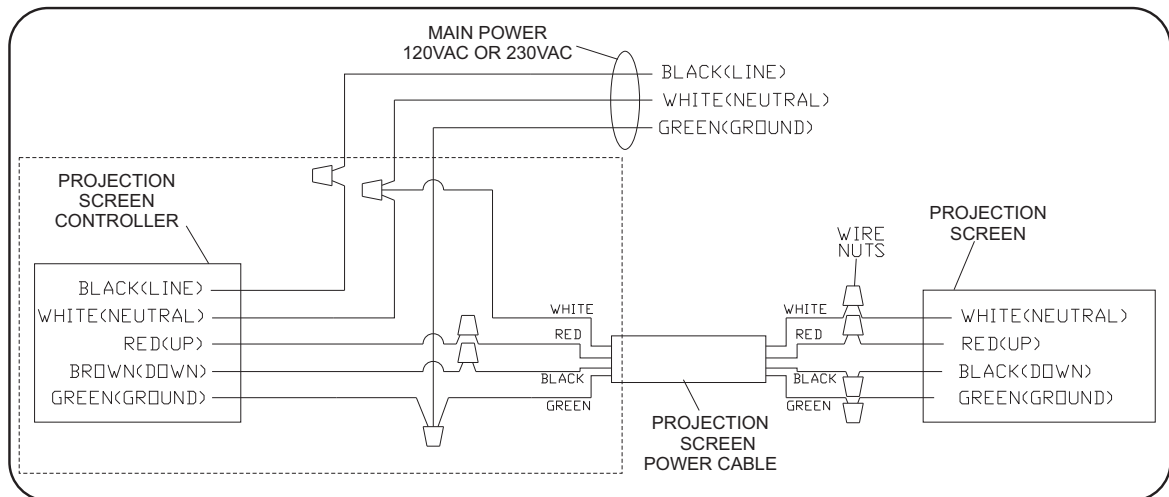
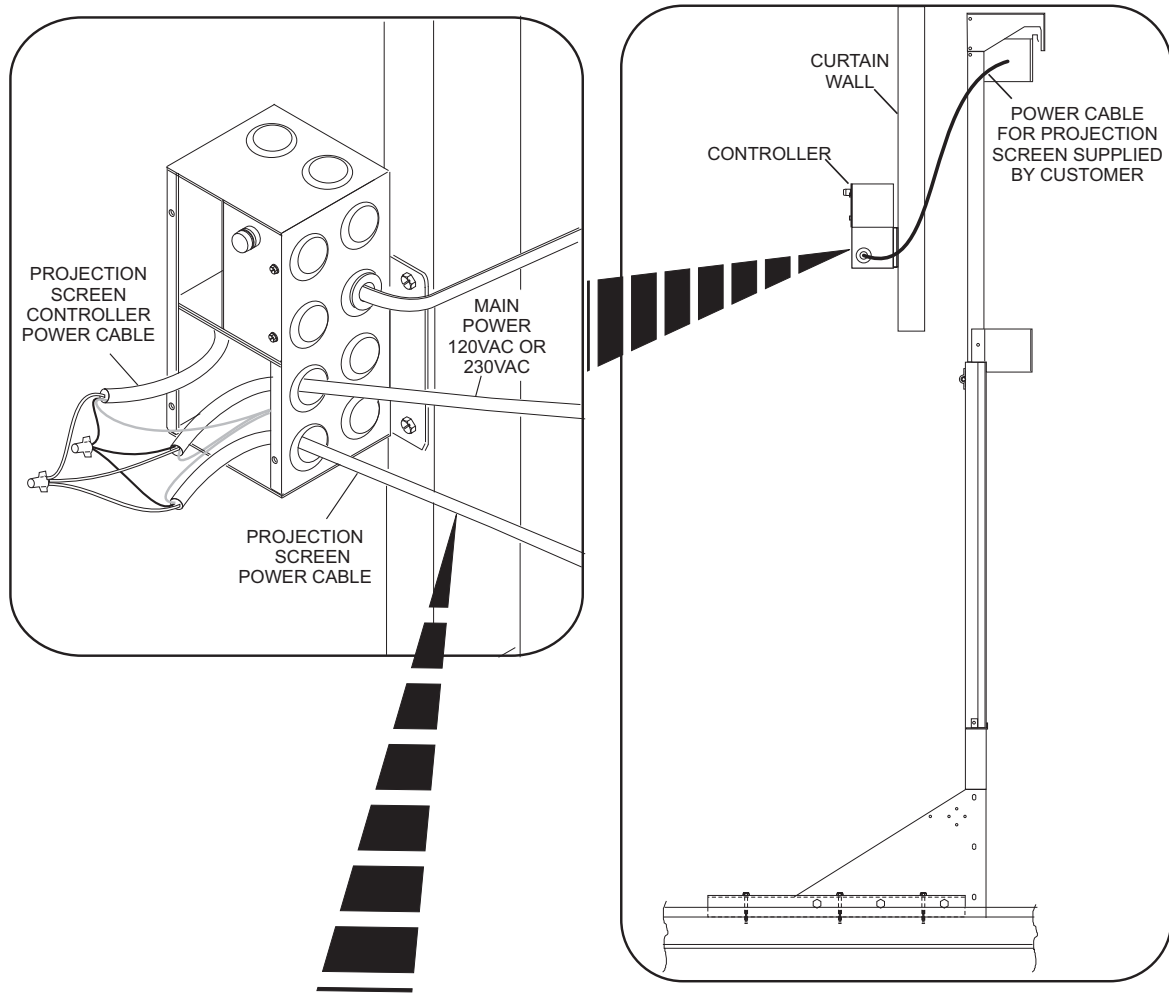

# Customer Responsibility - Standard Projector - Closed Ceiling

## Customer Responsibility for Projector Installation - Closed Ceiling

1. The customer is responsible for providing a support structure to which the aircraft cables attach, usually a metal bar or wood beam, that will support the weight load of the projector. Refer to the system overview graphic below and the projector mounting detail on the following page.

**i** NOTE: Customer is responsible for all video cabling and video equipment connected to projector.

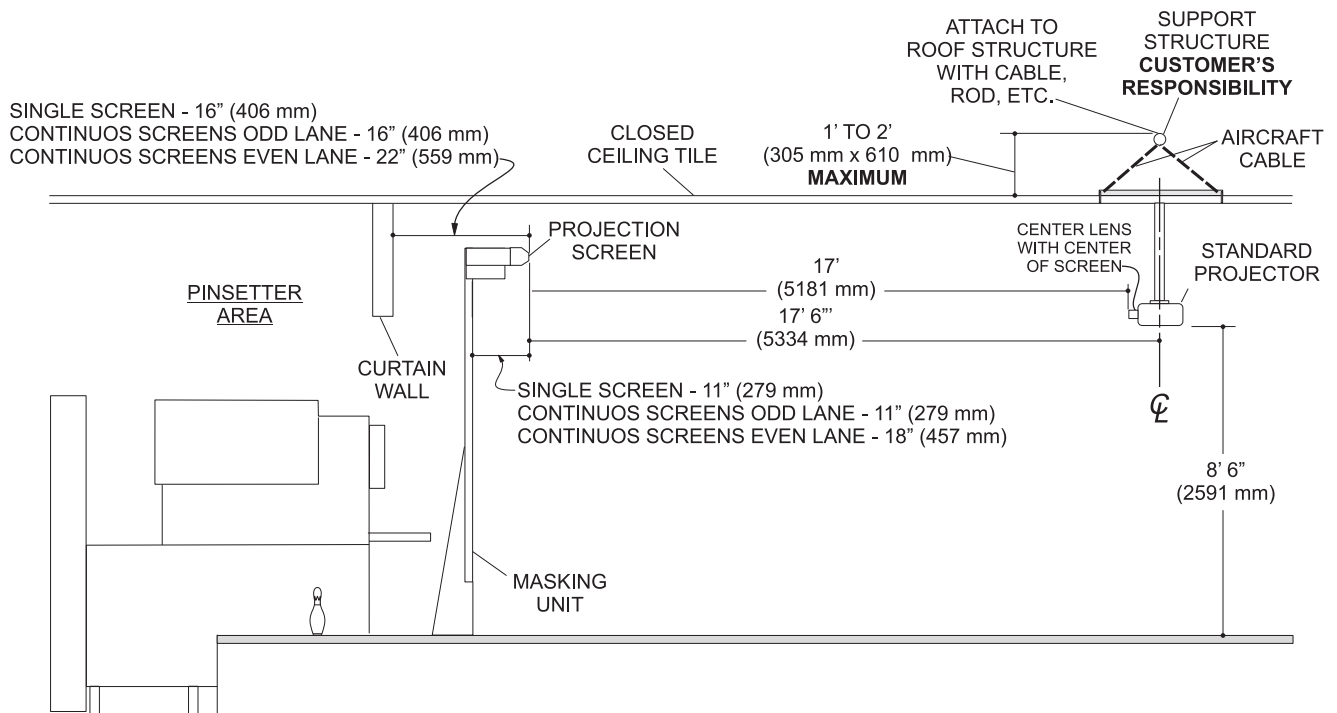

**PROJECTION SYSTEM OVERVIEW  
CLOSED CEILING**

# Customer Responsibility - High Output Projector - Closed Ceiling

## Customer Responsibility for Projector Installation - Closed Ceiling

1. The customer is responsible for providing a support structure to which the aircraft cables attach, usually a metal bar or wood beam, that will support the weight load of the projector. Refer to the system overview graphic below and the projector mounting detail on the following page.

**i** NOTE: Customer is responsible for all video cabling and video equipment connected to projector.

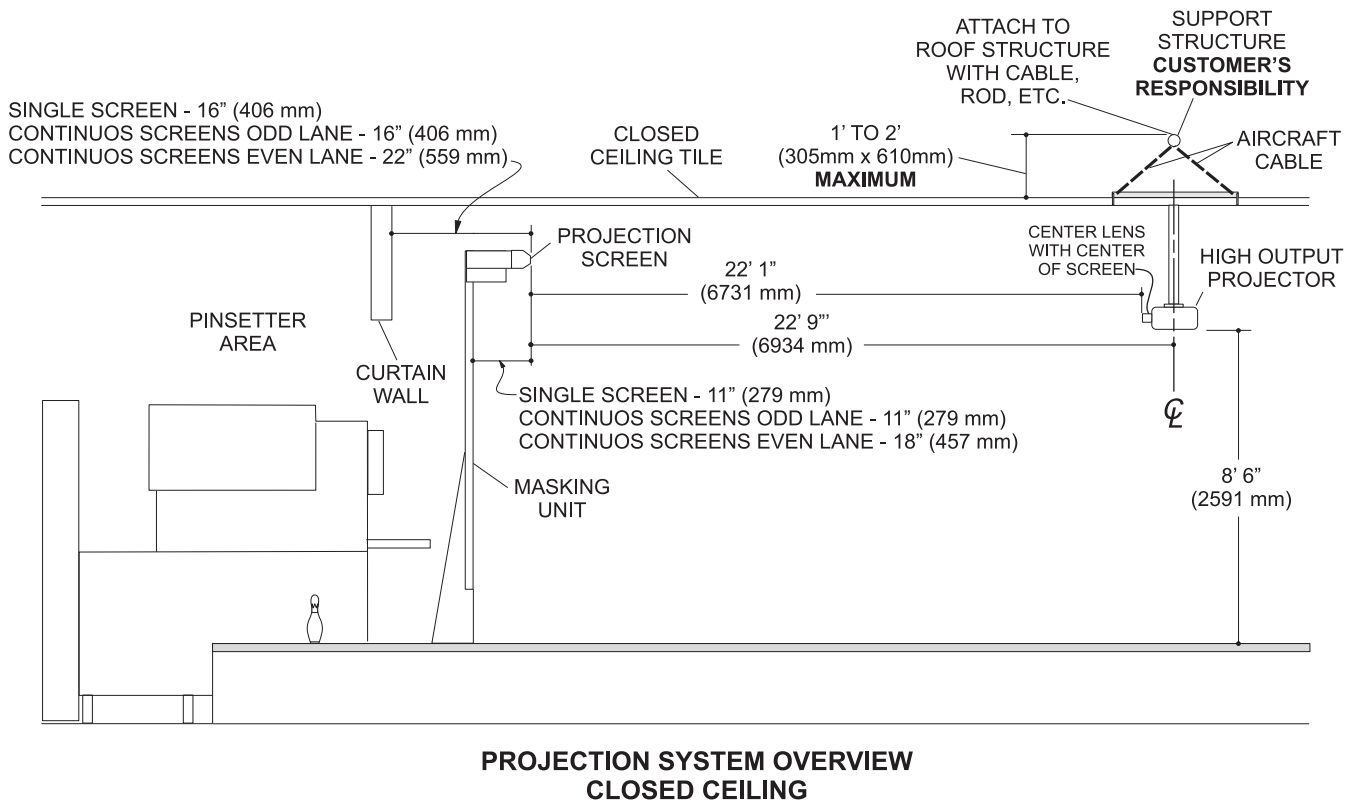

# Customer Responsibility - Projector - Closed Ceiling

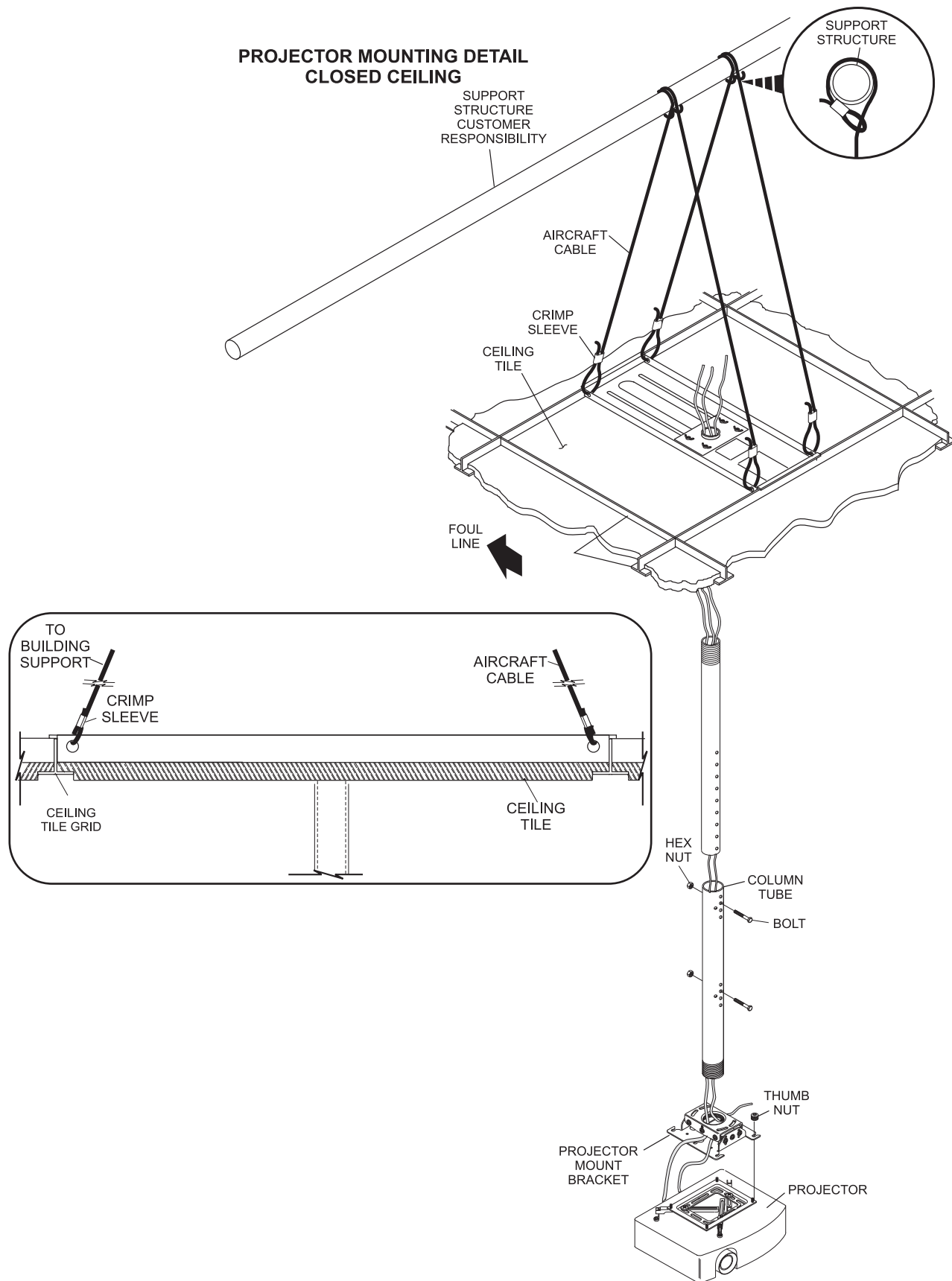

# Customer Responsibility - Standard Projector - Open Ceiling

## Customer Responsibility for Projector Installation - Open Ceiling

1. The customer is responsible for providing 1-1/2" pipe male NPT. Refer to the system overview graphic below and the projector mounting detail on the following page.
2. The pipe should be located 12' (3.66 m) above the lane and 17' 6" (5334 mm) from the projection screen, toward the foul line.

**i** NOTE: Customer is responsible for all video cabling and video equipment connected to projector.

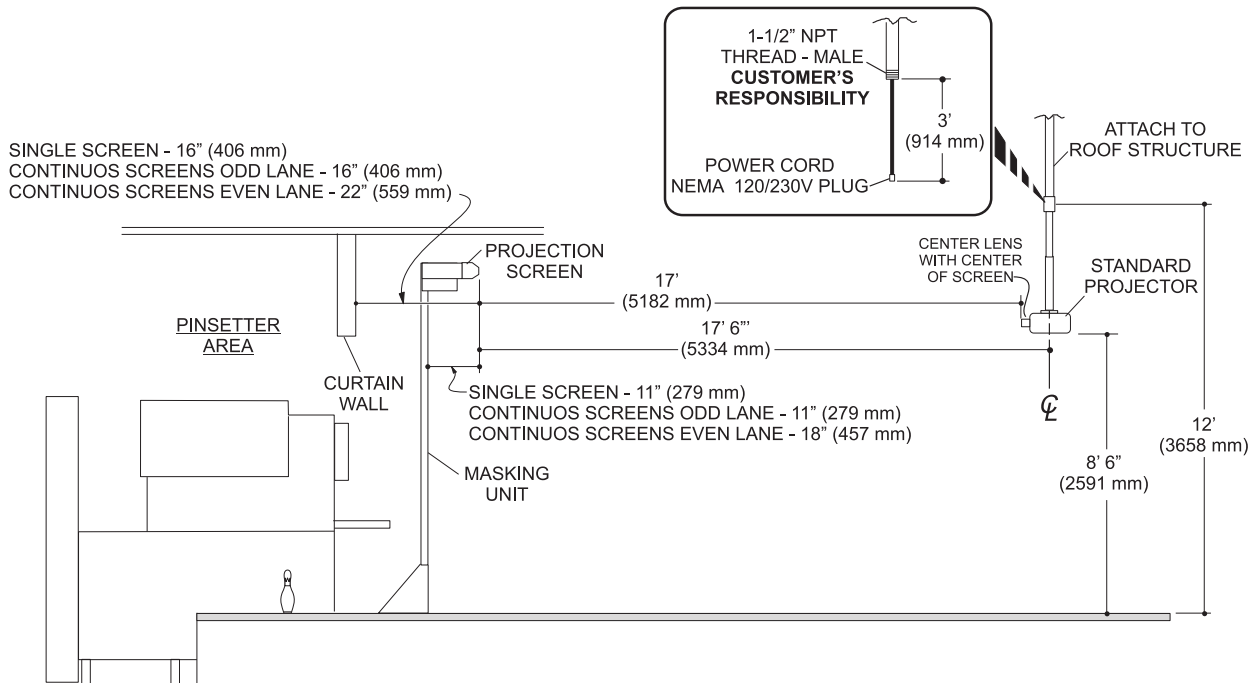

**PROJECTION SYSTEM OVERVIEW  
OPEN CEILING SIDE VIEW**

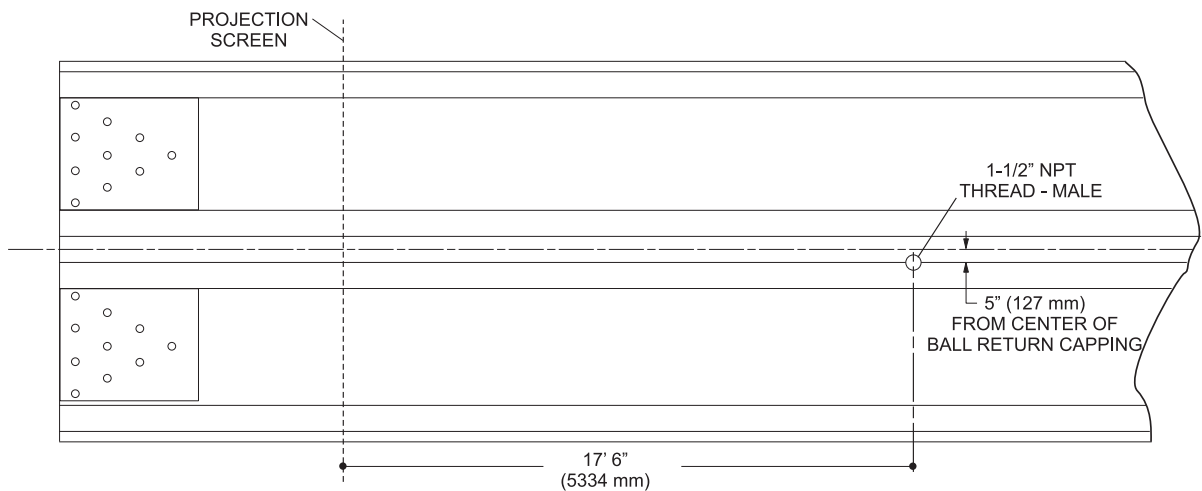

**PROJECTION SYSTEM OVERVIEW  
OPEN CEILING TOP VIEW**

# Customer Responsibility - High Output Projector - Open Ceiling

## Customer Responsibility for Projector Installation - Open Ceiling

1. The customer is responsible for providing 1-1/2" pipe male NTP. Refer to the system overview graphic below and the projector mounting detail on the following page.
2. The pipe should be located 12' (3658 mm) above the lane and 22' 9" (6934 mm) from the projection screen, toward the foul line.

**i** NOTE: Customer is responsible for all video cabling and video equipment connected to projector.

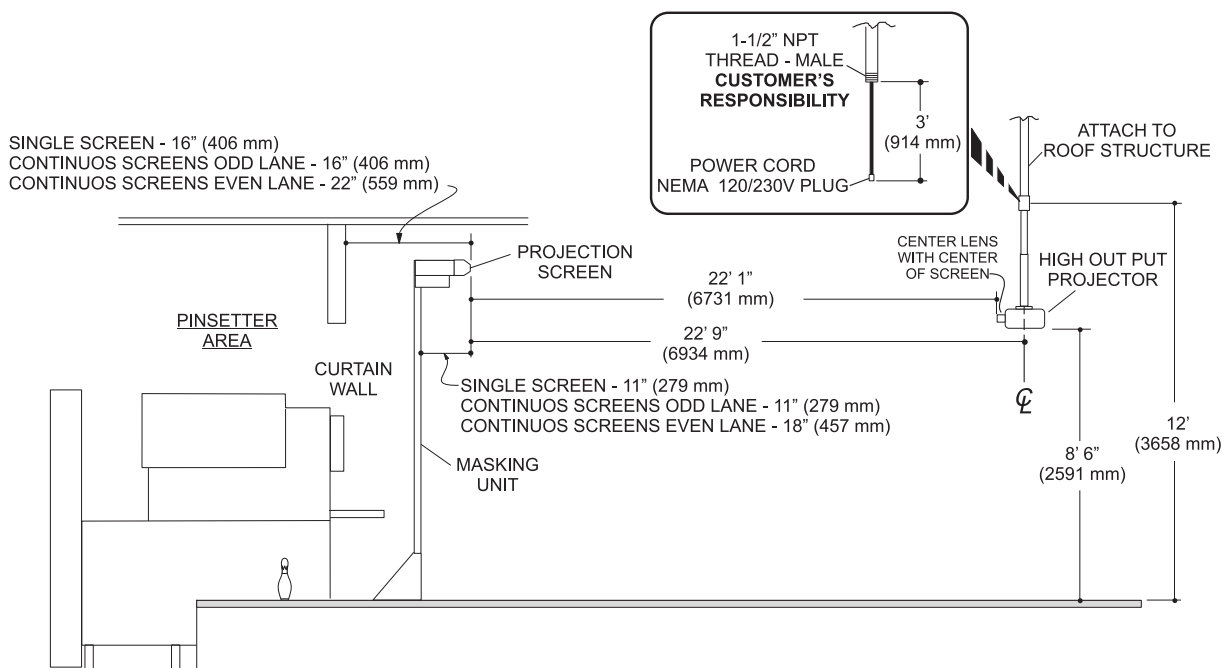

**PROJECTION SYSTEM OVERVIEW  
OPEN CEILING SIDE VIEW**

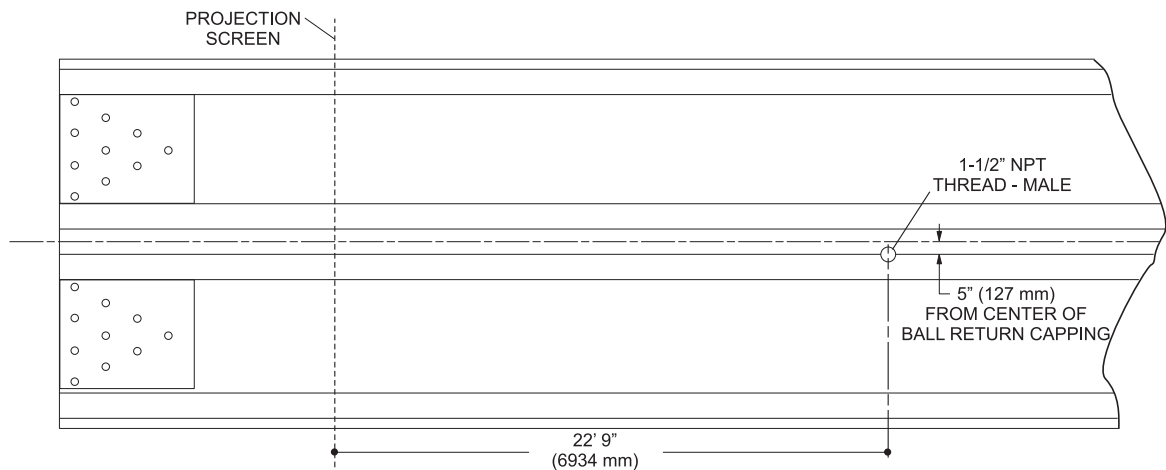

**PROJECTION SYSTEM OVERVIEW  
OPEN CEILING TOP VIEW**

# Customer Responsibility - Projector - Open Ceiling

---

## PROJECTOR MOUNTING DETAIL OPEN CEILING

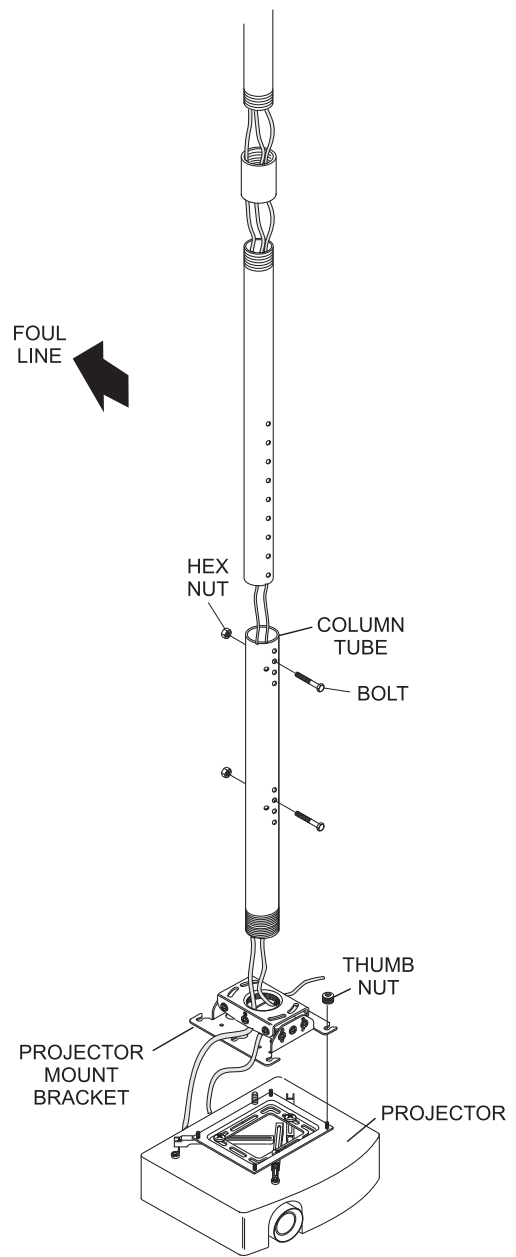

# Multiple Screen Layout 12 Lanes Standard Projectors

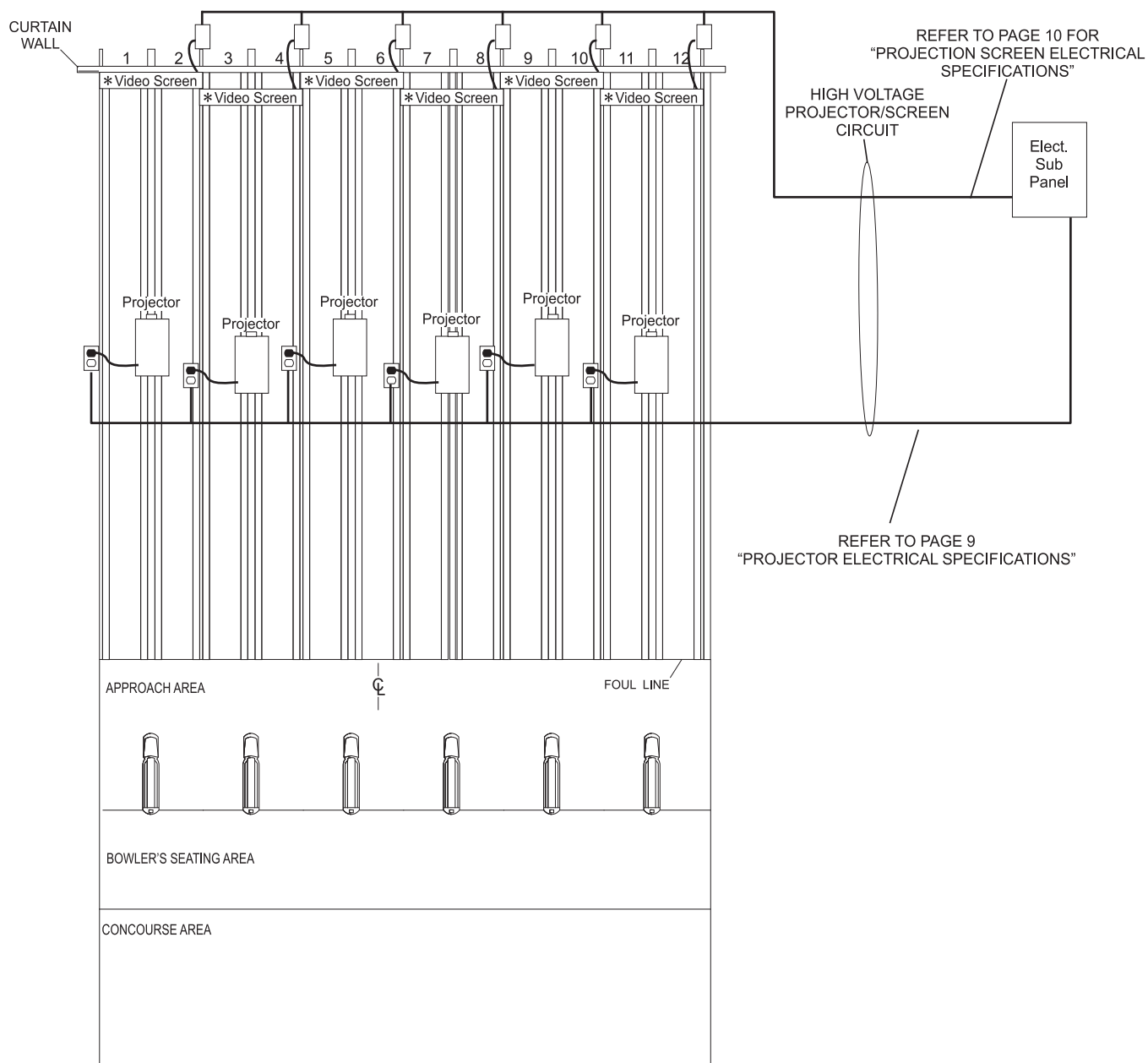

# Suggested Light Planning

## Operation

It is desirable to control lane lighting longitudinally in bays of four lanes per switch at the control desk. A more compact panel board can be planned if the electrician uses low voltage from control desk to activators at the light panel. Brunswick suggests tamper proof switches for lighting in public areas, or switching public area lighting from circuit breaker panels.

This will allow lighting adjustment during Lanescape Video Masking Unit operation, maximizing the image brightness.

