

*Lane Care Manual*

---

# **Synthetic Lanes**

October 2004/ 52-900220-000

**Brunswick**®   
CUSTOMER SERVICE  
A tradition in excellence.

### *Statement of Intent*

*This manual is provided to be used by qualified bowling center personnel. Customer accepts responsibility for safety training of all personnel who service and maintain this product.*

### **Synthetic Lane Care Manual**

© October 2004 by the Brunswick Bowling and Billiards Corporation. All rights reserved.

Reorder Part No. 52-900220-000

All information contained in this document is subject to change without notice. Do not reproduce or disclose without the written consent of the Brunswick Indoor Recreation Group.

Notice: If available, updates to this manual can be found on-line at [www.BrunswickBowling.com](http://www.BrunswickBowling.com).

Brunswick Bowling & Billiards Corp.  
525 W. Laketon Avenue  
Post Office Box 329  
Muskegon, MI 49443-0329  
U.S.A.

231.725.3300

---

## Table of Contents

<b>Section 1: Introduction .....</b>	<b>5</b>
Product Description .....	5
Introduction to Lane Maintenance .....	5
Lane Conditioning .....	5
Atmospheric Conditions .....	5
Lane Cleaning .....	6
Lane Dusting .....	6
Approach Cleaning .....	6
Lane Maintenance Equipment .....	7
Fluid Metering Technology .....	7
Wick Technology .....	7
Governing Bodies/Regulatory .....	7
Materials That Should Never be Used on Brunswick Synthetic Lanes .....	8
Approaches .....	8
Conditioners and Cleaners .....	8
Sanding and Buffing .....	8
<b>Section 2: Lane Care .....</b>	<b>9</b>
Lane Conditioning .....	9
Lane Conditioner Patterns .....	9
Lane Conditioners .....	11
Lane Cleaning .....	11
Lane Cleaners .....	11
Lane Cleaning Procedures .....	12
Lane Dusting .....	12
Lane Dusting Procedures .....	13
Gutter and Capping Cleaning and Dusting Procedures .....	14
Pit End Maintenance .....	15
Pin Deck Cleaning .....	15
Preventive Maintenance .....	15
Sealing of Lane Panel Seams .....	15
Trimming Excess Joint Sealer .....	15
Replacing Joint Sealer .....	16
Screw Plugs .....	16
Patching and Replacing .....	16
<b>Section 3: Approach Care .....</b>	<b>17</b>
Approach Cleaning/Maintenance .....	17
Approach Moisture Removal .....	18
Approach Conditioning .....	20
Approach Treatment .....	21
Brunswick Friction Sled Test Procedure .....	21
<b>Section 4: Troubleshooting .....</b>	<b>23</b>
Problem: Bowlers Complain About Sticky Approaches .....	23
Cause 1: High Humidity .....	24
Remedy A .....	24
Remedy B .....	24

Remedy C .....	24
Remedy D .....	24
Remedy E .....	24
Cause 2: Contamination from Bowler's Shoes .....	25
Remedy A .....	25
Cause 3: Spills or Food on the Approach .....	25
Remedy A .....	25
Cause 4: Contamination by Detergent or Soap Residue .....	25
Remedy A .....	25
Cause 5: Contamination from Lane Conditioning .....	26
Remedy A .....	26
Remedy B .....	26
Remedy C .....	26
Cause 6: Contamination by Wax .....	26
Remedy A .....	26
Cause 7: Contamination by Carpeting .....	27
Remedy A .....	27
Problem: Slippery Approaches .....	28
Cause 1: Extremely Low Humidity .....	28
Remedy A .....	28
Cause 2: Hot Air Blowing on the Approach. ....	28
Remedy A .....	28
Cause 3: Static Electricity Buildup .....	28
Remedy A .....	28
Problem: Too Much Carry Down .....	28
Remedy: .....	28
Problem: Too Much Backend Reaction .....	29
Remedy: .....	29
Problem: Not Enough Hold .....	29
Remedy: .....	29
Problem: Heads Hook Too Much .....	29
Remedy: .....	29
Problem: Not Enough Swing Area .....	30
Remedy : .....	30
Problem: Track Dries Up Too Quickly .....	31
Remedy: .....	31
<b>Section 5: Lane Maintenance Schedule .....</b>	<b>32</b>
General Maintenance Schedule .....	32
Daily Maintenance .....	32
Weekly Maintenance .....	32
Monthly Maintenance .....	32

# Section 1: Introduction

---

## Product Description

Brunswick synthetic lanes are reinforced synthetic composite designed to have the appearance of wood lanes. It has a durable, long-lasting and consistent bowling surface. The surface is constructed with fine particles of resistant aluminum oxide dispersed in a fiber-reinforced matrix of melamine resin. The melamine is translucent, allowing the wood-like printed layer to be visible.

---

## Introduction to Lane Maintenance

Lane maintenance is performed to protect the lane surface and to create an appropriate environment for rolling a bowling ball down the lane. The frequency and nature of lane maintenance tasks and the products used to perform those tasks are common to all bowling lane surfaces. The goal is to develop procedures which create a consistent bowling characteristic for the bowlers, while insuring the lane surface is coated sufficiently to minimize wear and extend the useful life of the lane. There are differences in maintenance procedures that are specific to certain types of lane surfaces. This manual is designed to help you maintain Brunswick synthetic lane surfaces.

As the industry leader in bowling lanes and bowling lane maintenance, Brunswick and the Brunswick family of brands will provide you with a single source for all your lane maintenance products and equipment. The Brunswick and DBA brands are recognized as industry leaders.

---

## Lane Conditioning

Lane conditioner is a lubricant that is used to protect the bowling lane from the bowling ball during the ball's journey down the lane.

***Note:** Without proper conditioning, the surface of the lane can be severely damaged, shortening its useful life, and can affect the product warranty.*

In competitive bowling markets, lane conditioning is also used to optimize the lane surface to create a good ball reaction environment for the bowler. The combination of the bowler's skill and the ball reaction environment created for the bowler is often the subject of much controversy within a bowling center. This is true for any bowling center whether the center primarily caters to the casual bowler or the competitive bowler.

## Atmospheric Conditions

It is important that proper climate control is maintained throughout the center. Indoor humidity is a large factor in lane conditions and approach sliding characteristics. A relative humidity level of 45% ± 5%, must be maintained to obtain optimum characteristics and performance from all equipment. Refer to "Section 3: Approach Care" for more information on this subject.

---

## **Lane Cleaning**

Because bowling lanes have lane conditioner applied to the bowling surface, dust in the bowling center air will come into contact with the lane conditioner and mix with the lane conditioner. It is a fact of bowling life that bowling lanes get dirty. When bowlers bowl on the lane, the motion of the bowling ball rolling down the lane mixes the dirt with the lane conditioner. This dirty lane conditioner is then carried down the lane to the area that does not have lane conditioner applied to it, to the pinsetter, and eventually to the bowler. In addition, lane conditioner moving down the lane will change bowling ball reaction as it approaches the bowling pins and adversely affect the scorability. Therefore, lanes must be cleaned regularly. The frequency depends on the amount of bowling that has taken place, and the bowling center environment. The process of using lane cleaner to clean a lane is often called *lane stripping*, *lane cleaning* or *lane washing*. Most bowling lanes are cleaned today using a vacuum lane cleaning mechanism in a lane cleaning machine or a combination lane conditioning and lane cleaning machine.

---

## **Lane Dusting**

Lane dusting uses a special duster cloth. Lane dusting is performed with a specially designed lane duster or with a lane duster that is integrated into a piece of lane maintenance equipment. The lane dusting equipment and lane duster cloth is designed to remove the layer of dirt on top of the lane conditioner without disturbing the lane conditioner pattern.

---

## **Approach Cleaning**

Bowlers expect a consistent sliding characteristic on the casual approach surface. Regular maintenance routines help assure this. Eventually, bowlers contaminate the surface of the approach by walking on them. Casual bowlers tend to create more contamination than competitive bowlers. Maintenance personnel need to recognize sources of contamination and minimize them.

---

## **Lane Maintenance Equipment**

Because lane maintenance tasks are labor intensive and require accurate use of lane maintenance products, these tasks are performed by both manual and automated lane maintenance equipment. Most lane maintenance equipment is now automated and often computerized. The two types of technologies used in today's lane machines are:

### **Fluid Metering Technology**

*Fluid Metering* is the most consistent, state of the art oil distribution system. Lane conditioner is drawn from the conditioner reservoir tank using a fluid-metering pump driven by a motor that runs constantly during operation. The pump draws a specific volume of conditioner during each revolution ( $\pm 1\%$ ). The lane conditioner fluid is then distributed to the transfer roller in a uniform stream. The lane conditioner pattern tells the machine the length of the lane conditioner stream, the number of conditioner streams, and the speed that the machine travels while performing the operation. Each pattern will have a specific lane conditioner volume output that can be varied through the *Program Volume Calibration* and the program work sheet.

### **Wick Technology**

The most common conditioner transfer system used by bowling centers for over 30 years. Processing uses felt material, which is seated into a tank allowing conditioner to absorb throughout the material and transfer to a stainless steel roller, a carpet roller or buffer brush onto the lane. Wick technology spans a broad range of equipment including multiple wicking pads and variable drive speeds to create greater pattern design capabilities compared to machines that offer single and four wick configurations and single drive speeds.

---

## **Governing Bodies/Regulatory**

Bowling organizations exist within every bowling country and a World Bowling Organization exists. The world bowling organization is the FIQ (Federation de International des Quilliers). The bowling organizations within the United States are the ABC/WIBC (American Bowling Congress/Women's International Bowling Congress). These organizations have adopted conditioning pattern rules specific to their countries. These conditioning rules typically reference "units" of conditioner. In the U.S., the current ABC/WIBC rule is known as the 3 unit rule. The FIQ has adopted a rule that requires a minimum of 5 units of conditioner. The exact rules for your bowling center should be obtained through your local bowling sanctioning organization.

---

## **Materials That Should Never be Used on Brunswick Synthetic Lanes**

### **Approaches**

Abrasive powders to improve sliding characteristics such as Easy Slide, Baby Powder, or Boric Acid should not be used on bowler's shoes or on the approach surface. These will leave residue on the approach surface that create an unfair surface characteristic for bowling opponents, which is against ABC Rules. In addition, many of these powders are abrasive or caustic to lane surfaces, which over time will damage the surface layer.

### **Conditioners and Cleaners**

Use only bowling industry approved products for synthetic lanes. Other oils, lubricants, and cleaning supplies may damage your synthetic lanes and void your warranty.

Always follow directions supplied by the manufacturer of all conditioners. If there is any question as to whether or not a new lane maintenance product can be used, contact your Brunswick Service Representative.

### **Sanding and Buffing**

Abrasive sanding and buffing pads should not be used on synthetic surfaces. After many years of use, the lane surface may develop an unusual amount of ball marking. Inadequate or improper lane conditioning normally causes this. However, if this surface damage does occur, the lane surface can be maintained using a polishing procedure. This procedure should not be repeated more often than 50,000 games bowled on the lane. For more information about this polishing procedure, contact your Brunswick Service Representative.

## Section 2: Lane Care

---

### Lane Conditioning

Lanes must be conditioned regularly, usually daily. Lane conditioner is a liquid, typically with a mineral oil base and an additive package to enhance its lubrication properties for bowling lane maintenance. Lane conditioner is also commonly referred to as *lane oil* or *lane dressing*. Lane conditioner is applied to the lane surface in a very thin film thickness. The lane conditioner has a shape or pattern to its application. The shape of the lane conditioner pattern is very important both left to right and from the foul line to the back of the lane. Lane conditioner is applied from the foul line to a pre determined distance from the foul line. Today's lane maintenance patterns are typically applied to a distance of approximately 40 feet from the foul line. The shape of the lane conditioner pattern is controlled by bowling organizations through rules. These rules are designed to help bowling center personnel apply a lane conditioning pattern that will create a positive bowling ball reaction environment while not creating a bowling advantage for any specific bowler or type of bowler.

---

### Lane Conditioner Patterns

Today's lane conditioner patterns are described in both normal volumetric terms and specially developed bowling volumetric terms. Most centers use ½ ounce or more lane conditioner for their daily lane conditioning patterns. For tournaments or centers with heavy lineage and defined play zones, volumes in excess of 1 ounce per lane are quite common. The board by board and foot by foot volume of the lane conditioner patterns is measured in “units” of conditioner. One unit of conditioner is defined as the film thickness resulting from the uniform application of 0.0167 cm<sup>3</sup> of conditioner to a square foot of bowling lane surface. The unit of conditioner designation therefore is used to report the film thickness of lane conditioner on the lane. The “unit” designation is linear. That means that 10 units of conditioner is five times more than 2 units of conditioner.

All bowling lanes need to be conditioned with less conditioner on the outside of the lane and more conditioner towards the center of the lane. More lane conditioner is used in the front of the lane and less conditioner is used at the end of the lane conditioner pattern. The average distance of lane conditioner application is 40 feet (12.2 m) +/- 4 feet (1.2 m)

The rate of change of the conditioner from less on the outside of the lanes to more towards the center of the lanes is controlled by the local bowling sanctioning association. In some countries, the distance of the lane conditioner pattern, measured from the foul line, is controlled by rule. It is **your** responsibility to check with your local bowling sanctioning organization to insure that your lane conditioning patterns are in compliance with applicable guidelines and rules.

The first component of the lane conditioning pattern for you to choose is the conditioning distance. For this example, the distance will be 40 feet from the foul line.

All bowling lane conditioner patterns have an “outside” and a “center” to the pattern. The *outside* of the conditioner is applied with very small volumes of lane conditioner. In the United States and Canada a minimum of three units of lane conditioner is required for the conditioned area of lane.

The conditioner in the *center* of the lane is far greater than the conditioner on the *outside* of the lane. It is possible and often recommended to have two *center* zones (L15-C20, C20-R15) in the center of the lane.

The intermediate zone between the center and the outside is called the *track*. This is the zone of the lane that sees the heaviest volume of play. More balls travel through this zone than any other zone of the lane. The *track* zone is a dynamic zone in that it changes as a result of bowling. The more bowling – the wider the *track* zone becomes and the more the *track* zone conditioner is depleted.

The recommended width of the *outside* zone of the lane is approximately 7 boards wide. The width of the *center* zone of the lane is approximately 7 boards wide. The zone between the *outside* of the lane and the *center* of the lane is called the *track* zone. The initial width of the *track* zone should be at least three boards but not more than 5 boards. Depending on your local lane conditioning rules and the type of lane maintenance equipment your center is using, the definition of the *outer*, *track* and *center* zones can be well defined or less obvious. The well defined zone definition from *outside* to *center* results in a lane conditioner pattern known as the “**step blend**”. The less well defined these zones are results in a “*blend*” or “*Christmas Tree*” pattern. Generally speaking, the wider and less defined the *track* zone is, the more challenging the lane conditioner pattern is. The more defined the *track* zone and the narrower (the minimum recommended width of the track zone is 3 boards) the *track* zone is, the less challenging the lane conditioner pattern is.

In general, the more zones in the lane conditioner pattern from the outside of the lane to the center of the lane, the smoother the lane conditioner pattern is and the more challenging the lane conditioning pattern will be for your bowlers.

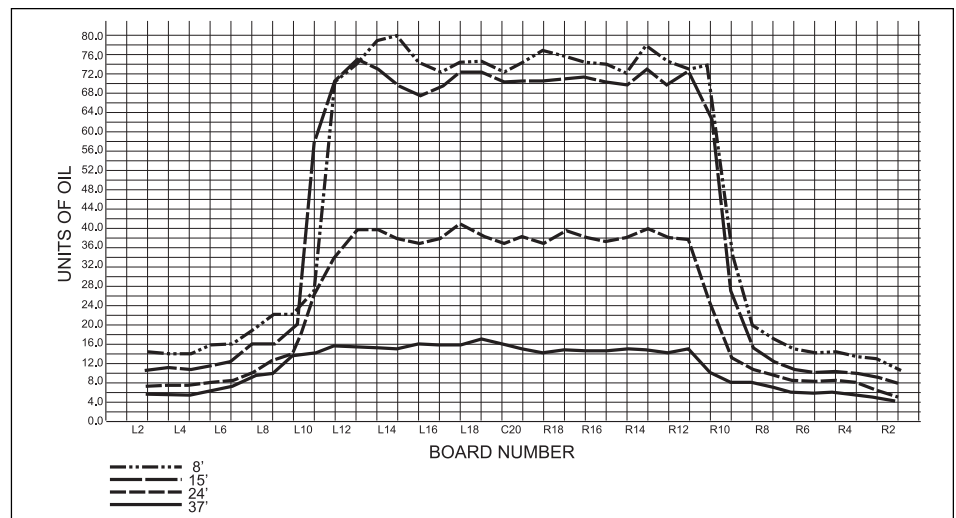

Typical Conditioner Pattern.

---

## Lane Conditioners

Lane conditioners are liquids specially formulated to protect the lane surface and create positive ball reaction when applied in a proper lane conditioner pattern. These liquids are oil based, contain various amounts of additives and contain a prescribed ratio of ultraviolet (UV) additive according to ABC/WIBC/FIQ specifications. This UV additive allows the film thickness of lane conditioner applied to a bowling lane to be determined by a lane monitoring system. These lane monitoring devices are the only devices approved for reading the film thickness of lane conditioner on any bowling lane surface.

Brunswick and DBA offer a full line of lane conditioners and a lane monitoring system.

Various conditioners have different physical properties, such as viscosity, surface tension, and flow rates, that relate to bowling performance. Refer to the manufacturer of the conditioner for the characteristics that best suit your center.

---

## Lane Cleaning

The bowling process disturbs and changes the lane conditioner pattern. Additionally, because we use an oil like substance to condition bowling lanes, these lanes get dirtier than other objects in the bowling center. Because of the lane conditioner pattern having changed and having been depleted as a result of bowling and the lanes becoming dirty, bowling lanes are cleaned on a regular basis. The lane cleaning process is designed to remove all old conditioner and dirt from the lane surface.

The recommending frequency for cleaning synthetic bowling lanes is daily. With today's lane maintenance equipment, the daily cleaning of bowling lanes is not a difficult process. Lane cleaning is also referred to as *lane washing* or *lane stripping*. In this manual we will refer to the process as *lane cleaning*.

---

## Lane Cleaners

Lane cleaners are the liquids used to clean today's synthetic bowling lanes. Almost all of these products are water-based lane cleaners. These lane cleaners are often diluted with water and used according to product directions. Refer to manufacturer of your lane cleaner for proper use.

---

## Lane Cleaning Procedures

*NOTE: Lanes must be cleaned with a vacuum lane cleaning machine. Vacuum lane cleaning machines are available through Brunswick/DBA as a combination conditioning and cleaning machine or as a separate lane cleaning machine.*

Today's modern lane conditioners are more effective. The increased volume of lane conditioner used and the chemical nature of today's lane conditioners often make the lane cleaning job difficult. As a general rule, the slower a vacuum lane cleaning machine moves down the lane, the more effective the lane cleaning performance. All professional bowling lane cleaners are labeled with specific directions and recommendations for use. For best economy of usage, use these bowling lane cleaners with maximum water dilution yet still strong enough to completely clean a bowling lane.

---

## Lane Dusting

Keeping lanes free from dust is an important part of any lane maintenance program. Lane conditioner contaminated with dust tends to break down faster than clean lane conditioner. Dirty lanes result in faster changing, less stable lane conditioner patterns. Dust on the lanes also gets on bowling balls. The bowling balls transfer dust to the pinsetters. Very quickly, this dust finds its way to your bowlers getting their shirts and hands dirty. The dirt and accompanying lane conditioner that comes into contact with your bowlers leads to complaints and lost business. To help avoid these problems, dust lanes at least twice per day. Dust gutters and capping at least once per day. Refer to *Figure 1*.



*Figure 1.*

*NOTE: Dust all lanes from pin deck to foul line.*

## Lane Dusting Procedures

Set the lane duster on the lane in front of the pins. Using only the pressure applied by the weight of the lane duster, push the duster into the pin deck area, moving the pins into the pit. With the lane duster now positioned at the end of the lane, drag the lane dusting unit behind you toward the foul line using only the pressure applied by the weight of the lane dusting unit. Continue dragging the lane duster unit toward the foul line. As the lane duster approaches the foul line, pick the lane dusting unit up away from the lane. ***Do not walk directly from the lanes on to the approach or allow the lane dusting unit to contact the approach area of the lane.*** If desired, the ***area of the lane*** immediately adjacent to the foul line can be cross-wiped with the lane dusting unit.

The ratchet mechanism on the lane dusting unit is then ratcheted, advancing the lane duster cloth. This provides clean lane duster cloth for use on the next lane. The procedure is then repeated for all lanes in the center.

Always dust the lane moving from the pin deck area toward the foul line. *Figure 2.* Never dust up some lanes and down others. Never use excess pressure on the lane dusting unit. Excess pressure will maximize the disturbance of the lane conditioner pattern. ***Do not walk directly from the lanes on to the approach.*** Conditioner picked up on shoes can contaminate the approach and make the approach sticky. Place a towel on the approach to step on whenever stepping from the lanes on to the approach.

If excessive lane dust is deposited on the lane side of the foul line after a lane is dusted, the lane dusting frequency needs to be increased. Cross wiping the area of the lane immediately adjacent to the foul line will remove this excess lane dust. Refer to *Figure 2.*

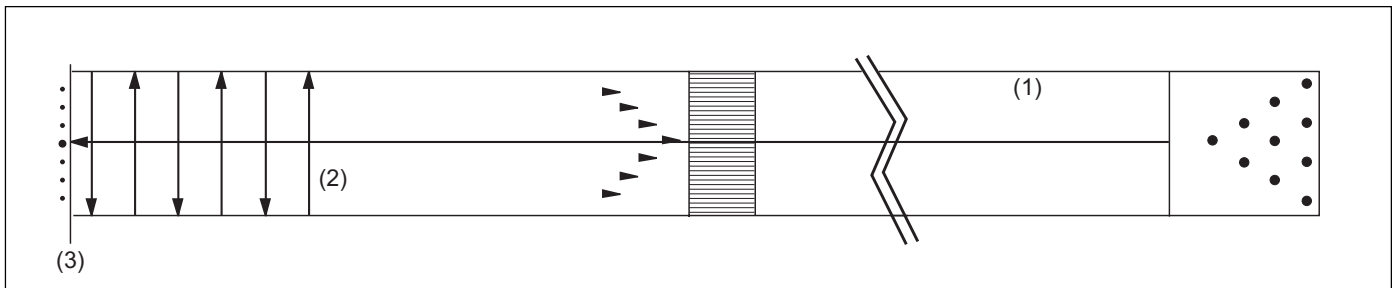

Figure 2.

- (1) ALWAYS DUST FROM PIN DECK AREA (2) CROSS WIPE ACROSS LANE (3) FOUL LINE  
**TOWARD FOUL LINE**

## Gutter and Capping Cleaning and Dusting Procedures

Dust gutters and capping daily. Clean weekly, bimonthly, or monthly with hot water or approved cleaner as needed. Wipe up any excess liquid (do not allow to evaporate). Any contamination or over spray of the gutters/capping from the lane conditioning or lane cleaning process should be immediately removed and cleaned with approved cleaner. Correct over spray by adjusting or maintaining the maintenance equipment in accordance with the equipment specifications.

**NOTE:** Some lane cleaners and conditioning materials may affect gutters and capping.

Use two pickup gutter mops, a box or container for dirt, and a large towel to dust these areas. Starting at the foul line, place both mop heads, one on top of the other to completely cover the capping. Walk on the ball return capping or division gutters, pushing the gutter mops toward the pins. Refer *Figure 3*. Dust around pinsensing equipment and dust the dropsweep cover. Place one mop in each flat gutter and pull into round gutter. Never push dirt and dust into the pit. Face the approach and push the mops in the gutter toward the foul line. Carefully shake dust and dirt into a container placed nearby for this purpose. Refer to *Figure 4*. Do not let this dust and dirt contact the approach, this may cause undesirable sliding conditions.

**NOTE:** All lane mops, gutter mops, and approach mops should be "non treated", the use of treated mops can leave tacky residues.

- (1) BALL RETURN CAPPING
- (2) DIVISION CAPPING
- (3) MOP

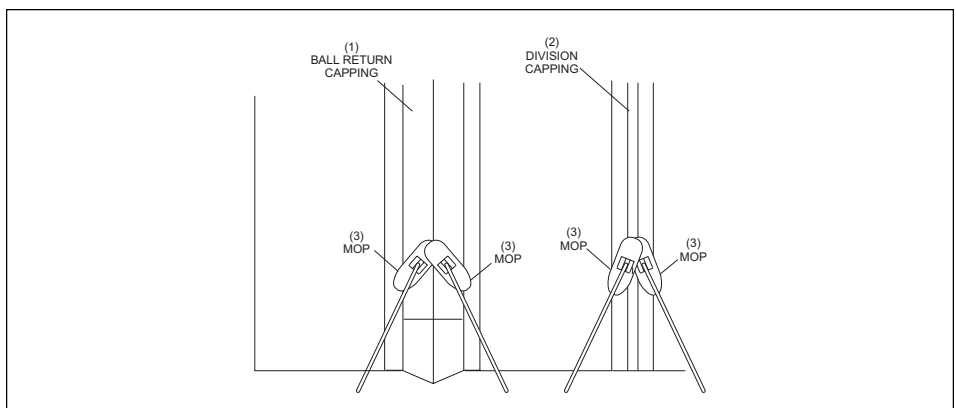

Figure 3.

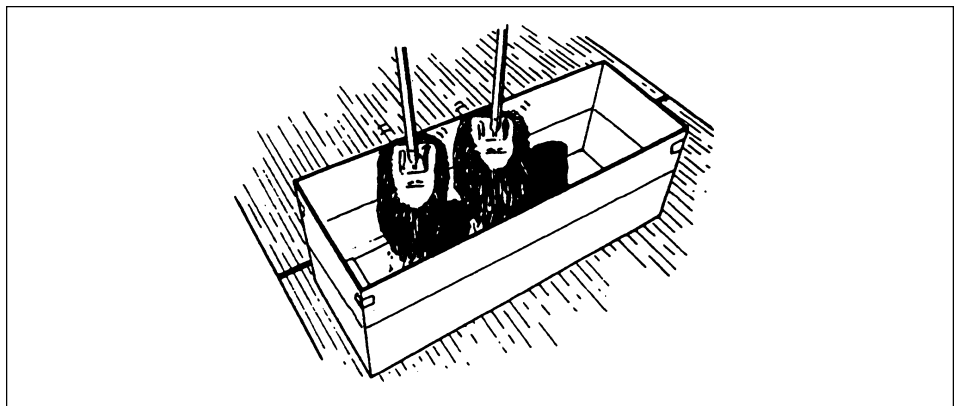

Figure 4.

Do not walk from the lane or gutters directly onto the approach, as conditioner picked up by your shoes will cause contamination of the approaches. Place a towel on the approach to step on when moving from lane to lane.

Mop heads should be laundered after being used on approximately 100 lanes. Keep extra mop heads on hand to replace those being laundered.

---

## **Pit End Maintenance**

Kickbacks and gutters should be cleaned once a month. Cut a 4" x 6" section from a clean polishing pad and soak the pad in the lane cleaner. Thoroughly scrub the kickbacks and flat gutters to remove all accumulated dirt. Before the cleaner dries, wipe thoroughly with a clean, soft cloth to remove cleaner and dirt.

---

## **Pin Deck Cleaning**

Fill a spray bottle or small bucket with an approved lane cleaner and water mixed at a 15:1 ratio (water: cleaner). Spray entire Pin Deck with cleaner mixture and clean using either a towel or a sponge floor mop. Wipe excessive moisture with dry towel. Only use Pin Deck treatment if necessary. Watch for issues pertaining to excessive carrydown and adjust conditioner pattern accordingly. Centers with an infrequent cleaning regimen may require cleaning on a daily basis.

For best pin action and pit end performance inspect the pit once every three months. Repair and replace any loose or damaged kickbacks, flat gutter, tail planks, pin decks, and all other pit end components.

---

## **Preventive Maintenance**

### **Sealing of Lane Panel Seams**

During the installation process, every panel seam on the lane surface has been sealed to prevent moisture penetration and dirt collecting in the seam. Panel seams should be checked once every three months to assure sealant has remained in place.

### **Trimming Excess Joint Sealer**

If the sealant has expanded above the lane surface, trim using a blade scraper perpendicular to the lanes seam, remove all excess material from the lane to prevent lane contamination

## **Replacing Joint Sealer**

If sealer has become loose or is missing it should be reapplied as soon as possible.

1. Using a utility knife remove as much of the old sealer as possible.
2. On both sides of the seam apply strips of 2" (51 mm) masking tape, 1/16" (1.58 mm) from the joint.
3. Apply tape to both sides of the tape seam to prevent the sealer from running into the gutters.
4. Install a tube of joint fill material (part number 84-200430-000) into the application gun (part number 84-200431-000). Cut the nozzle on the tube of silicone large enough to fit over the seam .
5. With the tube in the caulking gun, press the nozzle against the seam. Begin to force the silicone into the seam until it is seen flowing out of the seam behind the nozzle. Slowly pull the nozzle across the seam.
6. Work the silicone into the seam with a putty knife and remove the excess material.

***IMPORTANT: Any excess silicone must be removed from any lane surface.***

7. After the silicone has cured approximately 2 hours, remove the tape.
8. Using a razor blade scraper, remove excess material from the lane.
9. Recheck all seams for void areas. Any voids areas must be filled.
10. Recheck all seams the following day. Using the razor blade scraper, re-trim any seams where the silicone is higher than the lane panel, on the pit end side of the joint.

## **Screw Plugs**

Check the screw plugs on the lane surface and approach once every three months. If the plugs become recessed or loose, it will be necessary to replace them with a tighter fitting plug to a fit that is flush with the lane surface.

## **Patching and Replacing**

The entire lane area and approach area should be checked daily for any visible damage. If there are any chips that may require patching, there are repair kits available from your distributor. If a panel has cracked or delaminated and requires replacing, please contact your Brunswick Authorized Distributor.

## Section 3: Approach Care

Synthetic approaches become sticky due to contamination or moisture. Most contaminants are liquids left by lane conditioning procedures or by bowlers. Bowlers can transfer liquids from spills in the bowler's area, from stepping in the lane oil (beyond the foul line), or from direct spills on the approach.

Contaminants can be transferred to the approach surface by the bowler's shoes or by the bowling ball itself. Bowlers who drop the ball in front of the foul line most likely will cause a ball mark on the approach, and may also transfer oil to the surface from the ball. Other not so obvious sources of contamination are floor wax transferred from floor tiles and carpet treatments such as ScotchGuard®.

Atmospheric conditions affect the approach surface. Sudden changes in temperature of the lane surface or the conditioned air flowing across it can cause water to condense on the approach surface. Relative humidity in a bowling center should be maintained at a constant level no higher than 50%. The more constant the temperature of the lane surface and the air in the building, the better. A relative humidity of  $45\% \pm 5\%$  is ideal at a constant indoor temperature of your choice.

***NOTE:** Prolonged exposure to high humidity, over time, can cause synthetic lanes to expand beyond their intended design. Relative humidity must be maintained at all times to provide maximum performance, reliability, and dependability.*

When contamination does occur, simple cleaning procedures are all that are necessary to restore the original sliding characteristics. Synthetic approaches do have different maintenance procedures than wooden ones.

---

### Approach Cleaning/Maintenance

Synthetic approaches require simple daily cleaning maintenance. This ensures consistent desired sliding characteristics for your bowlers.

**Daily Maintenance** - Dust approaches with a dry mop used only on approaches. Dust in the morning and afternoon. Dusting should be done before any type of buffing or spot cleaning. Use approach conditioner if necessary in the slide area only.

**Weekly Maintenance** - Dust approach and buff using 70-99% isopropyl alcohol. Use generous amounts and buff the entire approach area. Apply approach conditioner if necessary in the slide area only.

**Spot Cleaning** - When spot cleaning, wipe entire slide area with 99% isopropyl alcohol. This will remove oil drips, lane cleaner drips, or foot prints from bowlers that stepped in the lane conditioner. It will help with ball or shoe scuff marks as well as other contaminants that have been transferred by bowler's shoes.

**NOTE:** A product that is an excellent solvent and cleaner is isopropyl alcohol. It also removes excess moisture from synthetic approaches. Isopropyl alcohol is available in 30% strength, 70% strength and 99% strength. Brunswick recommends the use of 99% isopropyl alcohol only as this cleaner has little or no water combined with the isopropyl alcohol. Alcohol is best for cleaning oil drips, oil footprints, lane conditioner, and cleaner drips.

**Tips:**

- Spot clean or buff the slide area after youth leagues or open play.
- If many approaches are dirty, use a rotary buffer.
- Use a carpet buffing pad or terry cloth towel. Make sure they are clean and dry when you start. Flip, rotate, or change the pad/cloth between 6-12 lanes, depending on the amount of dirt you are picking up.
- When washing pads and towels, DO NOT use laundry detergents that have special additives that leave a residue on pads or towels.
- DO NOT use fabric softeners when cleaning pads or towels.

**Approach Moisture Removal**

The slide area of the approach is the area of the approach that should be maintained to provide your bowlers with optimal approach slide characteristics. The slide area of the approach is the 3 to 4 foot distance of approach immediately adjacent to the foul line and includes the fill areas of the approach. Refer to Figure 5.

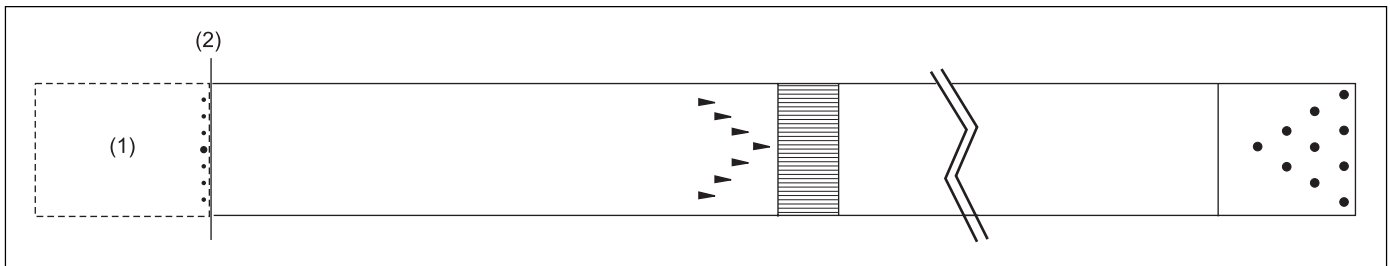

Figure 5.

(1) SLIDE AREA OF APPROACH

(2) FOUL LINE

**IMPORTANT:** Prior to performing this procedure, spot clean any areas of the approach that need to be cleaned of any spilled liquids, shoe contaminants or foreign materials.

Using a spray bottle containing 99% isopropyl alcohol, wet the slide area of the approach on one approach only. Using a terry cloth towel, dry the slide area of the approach. Allow any remaining isopropyl alcohol to evaporate. Perform a test slide on the treated approach. To perform this procedure on multiple approaches, use a rotary floor machine with a clean terry cloth towel or carpet buffing pad under the buffer.

***WARNING: Do not use abrasive buffing pads on synthetic surfaces.***

Spray the 99% isopropyl alcohol over the slide area of the approach to be cleaned. Clean one approach at a time. Be sure to clean the approach slide area in front of the ball return and division capping. Repeat this procedure for all approaches in the bowling center. Perform this procedure as often as necessary.

---

## Approach Conditioning

Approach conditioning is the process of changing the slide characteristics of the approach. Care should be taken when implementing such a program because bowlers need consistent and predictable slide conditions. This need is for both safety and competitive reasons. Specific products are made to enhance the slide characteristics of Anvilane Pro Lane and other synthetic approaches. These products are used in a specific manner following directions included on the product packaging. Approach conditioning often utilizes a series of products. The information below details recommended products, product use sequences and procedures. *Always refer to the procedures for use detailed on the product labels.*

Approach conditioning uses a liquid based product. These products apply a thin film of material designed to increase the slide characteristics of a synthetic approach. The sliding process on the approach is abrasive and as such will abrade this film of material from the approach surface. Eventually, all of the material will wear from the approach surface in locations where bowlers slide the most. Finally, uneven slide characteristics will be experienced by the bowlers. Therefore, this procedure should be repeated as necessary. Always follow the directions on the product labels.

Approach conditioners can be used on a single approach or for multiple approaches. Spot use of approach conditioner may be necessary after cleaning up a spill. After the spill has been cleaned, test the slide on that area of the approach. If conditioning is needed, spray a thin film of approach conditioner on the area of the single approach to be conditioned. Be careful not to allow any over spray of approach conditioner to contact the bowling lane, capping, or gutters beyond the foul line. Using a terry cloth towel, wipe the approach conditioner on to the area of approach to be conditioned. Using a dry terry cloth towel, insure that this area of the approach is dry and ready for bowlers to use the approach. Test slide on the approach to verify that it is ready for bowlers.

For use on a regular basis (determined by specific center need), use a rotary floor machine.

***WARNING: Do not use abrasive buffing pads on synthetic surfaces.***

Using a spray bottle, apply a thin film of approach conditioner to a single approach. Be careful not to allow any over spray of approach conditioner to contact the bowling lane, capping, or gutters beyond the foul line. With a terry cloth towel or pad under the rotary floor machine, buff the approach conditioner thoroughly and evenly on to the approach. Allow to dry. Test slide on the approach to verify that it is ready for bowlers.

---

## Approach Treatment

Approach treatment is a process used for both wood and synthetic approaches. Prior to using approach treatment, make sure the approaches to be treated are thoroughly cleaned. Approach treatment is only applied to the slide area of the approach. It is Step 1 of a multi-step procedure based on environmental conditions within the bowling center.

Approach treatment can be used on an individual approach or for multiple approaches in the center. To use approach treatment on a single approach to treat an isolated approach problem or after cleaning up a spill on the approach, use a terry cloth towel to apply approach treatment to the slide area of the approach. Thoroughly wipe approach treatment on to the slide area of the approach. Using a clean, dry terry cloth towel, wipe the entire slide area of the approach until the slide area is dry.

For multiple approaches, repeat the procedure above using a rotary buffer with a terry cloth towel under the rotary buffer rather than hand use of the terry cloth towel.

***WARNING: Do not use abrasive buffing pads on synthetic surfaces.***

Continue to treat one approach at a time.

Approach treatment should be done as often as necessary.

---

## Brunswick Friction Sled Test Procedure

1. Clean the approach surface with a clean, dry cloth to remove any dust, powder, or oil. Make sure the surface is completely dry. This may require the use of 70-99% isopropyl alcohol.
2. Clean the three leather slides on the bottom of the friction sled (part no. 52-860184-000) with 320 grit silicon carbide sandpaper.
3. Place the friction sled at the foul line with the leather slides against the approach surface. Place a 16 pound bowling ball on top of the sled resting between the three rubber support pads. See *Figure 6*.
4. Connect the hook of the spring scale in the eye of the friction sled.
5. Pull on the spring scale with an even force horizontal to the approach surface. Keep just enough pulling force to keep the sled moving at a steady rate.
6. Observe and record the kilogram (kg) reading on the spring scale. (To convert kg to grams multiply by 1000).

7. Take friction readings at center board of the approach at the foul line and 18 boards to the left and right of the center board (three locations). While most bowlers slide in the center, often bowlers use outer areas to shoot at spares.
8. An acceptable scale reading is between 1,800 and 2,500 grams. If readings are above 2,500 grams, the surface may be contaminated or wet. Follow the troubleshooting procedures described earlier in the manual to correct “sticky approaches.”

- (1) 16 LB. BALL
- (2) FRICTION SLED
- (3) SPRING SCALE

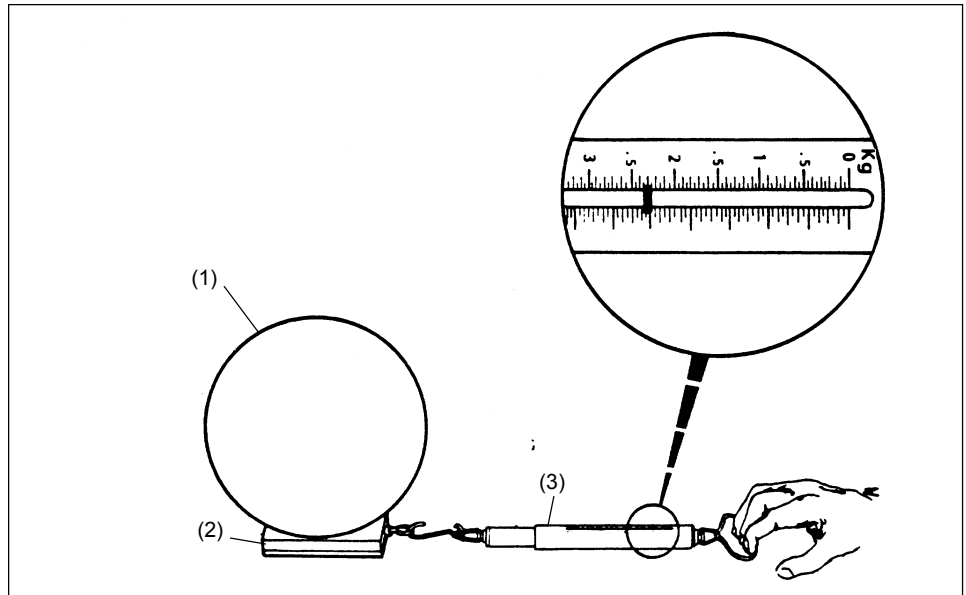

Figure 6.

## Section 4: Troubleshooting

**NOTE:** Prolonged high humidity can cause the synthetic lane panels to expand beyond their design and installation specifications with the symptoms being shown as flexing of the panels. Flexing is initially seen on the foul line panel, and this can cause ABC specification violations in the lane area.

**Remedy:** Control humidity levels as recommended. As it took months for the panels to absorb the excessive moisture, it will take months for the panels to “relax” to the original size.

---

### **Problem: Bowlers Complain About Sticky Approaches**

Sticky approaches can occur on any type of lane surface (wood or synthetic). Often, it is attributable to the bowler’s style of bowling and type of shoe. Bowlers that place their heel on the floor early in their slide will stop more quickly than those who do not. Bowling shoes that have smooth surfaces will adhere to the approach surface and create higher resistance to sliding.

The surface of the approach can be contaminated. Contamination in the form of liquids or solids can be deposited on the surface to create sticky approaches. Lane oil and cleaner do not simply wipe up, they smear covering a larger area. Use isopropyl alcohol or approach spot cleaner. Always perform a test slide.

If a bowler reports a legitimate sliding problem, the first thing to do is to check the bowler’s shoes. Make sure the soles and heels are clean and dry. While walking around in the bowling center (visiting rest rooms, bar, food area, etc.) the bowler may contaminate the bottoms of their shoes. If the bowler’s shoes are not contaminated, check the bowler’s area and approach surface for spillage or foreign materials.

The following are causes and remedies for common approach contamination. Brunswick recommends you purchase Approach Spot Cleaner, Approach Cleaner, or 70-99% isopropyl alcohol to use in the cleaning process.

Brunswick sells an instrument for measuring the resistance to sliding on the approach surface. The Brunswick Friction Sled (part number 52-860184-000) measures the relative friction of the surface. These measurements can be used to troubleshoot problems, confirm correction of problems, or verify that maintenance procedures are effective. Instructions are included with the sled. Typically, approach surface friction readings between 1,800-2,500 grams are acceptable.

---

## **Cause 1: High Humidity**

During warm weather and periods of outdoor precipitation, humidity levels can rise inside the bowling center. If large groups of people enter the building, humidity levels can rise quickly. The recommended relative indoor humidity for a bowling center is 45%, plus or minus 5%. It should be no higher than 50%. The regular use of a digital hygrometer is recommended to monitor the indoor relative humidity at all times. If the humidity is high, or suddenly changes, moisture may condense on the approach surface. Depending on the temperature and flow of air across the approach area, this condition could be worsened. Warm, moist air blown across a cold lane surface will cause condensation. In any case, when moisture condenses on the approach surface, sliding conditions can become sticky.

### **Remedy A**

Maintain the humidity and temperature at a *constant level* at readings of 45% ± 5%, IRH and 68 degrees Fahrenheit (±5 degrees) respectively.

### **Remedy B**

Force air to circulate away from the foul line, toward the bowler's area. This may require a design change in HVAC ducts and vents, but may be as simple as changing the directions ceiling fans rotate. By forcing air back away from the approach, humidity brought into the building by bowlers, and by bowler activity can be drawn back to the bowler's area, and carried away in HVAC return ducts.

### **Remedy C**

Make sure fresh air dampers for HVAC units close automatically when outdoor humidity levels are high.

### **Remedy D**

Temporary cures for condensation on the approach would be the use of a clean dry approach mop, or 99% isopropyl alcohol on a terry cloth towel to drive away the moisture.

### **Remedy E**

Make sure bowlers remove wet clothing and shoes as far away from the bowler's area as possible. Use of locker rooms and entrances is recommended.

---

## **Cause 2: Contamination from Bowler's Shoes**

The transfer of materials and moisture on bowler's shoes causes most approach contamination. The source of the contaminant as well as the shoes themselves must be corrected.

### **Remedy A**

Clean the bowler's shoes. Using a wire brush or 400+ grit sandpaper, loosen and remove foreign materials, and roughen the leather sole. **DO NOT WASH SOLES WITH SOAP OR DETERGENTS.** Isopropyl alcohol may be used to dissolve foreign materials.

***NOTE:** Clean rubber or plastic soles will act as a brake during bowling, and could cause certain bowlers to stick.*

---

## **Cause 3: Spills or Food on the Approach**

### **Remedy A**

It is advisable to forbid the consumption of food or drink immediately adjacent to the approach. The bowler's shoes will eventually transfer any spillage to the approach. If spillage occurs on the approach itself, immediately clean it up. For water soluble foods, use warm water followed by 99% isopropyl alcohol to drive away excess moisture. For oily contamination, use 99% isopropyl alcohol only. Brunswick Approach Spot Cleaner (part number 62-860034-001) may also be used.

---

## **Cause 4: Contamination by Detergent or Soap Residue**

### **Remedy A**

Never use soaps or detergents to clean approach surfaces. Do not drip these agents on the approach when cleaning capping or gutters.

---

## **Cause 5: Contamination from Lane Conditioning**

Over spray, dripping, and tracking of lane conditioner contributes to contamination of the approach surface.

### **Remedy A**

From equipment or tools. Keep any lane conditioning tools and equipment in clean, working order. Excessive oil buildup in the machine may allow oil to drip on the approach during transfer from lane to lane. Do not lay lane conditioning tools on the approach. Do not overfill conditioner or cleaner reservoirs.

### **Remedy B**

Oil too close to foul line. Often, bowlers slide over the foul line when bowling. This is especially true for open bowlers. One trick is to keep foul units on at all times to remind bowlers to stay back. Another trick is to remove lane conditioner for the first few inches on the lane side of the foul line. The amount of ball marks in this area may be worth more than the sticky conditions caused by oil on the bowler's shoes.

When removing the oil *from the lane side of the foul line*, use 99% isopropyl alcohol on a *separate cloth*. Make sure this cloth is not used on the approach side of the foul line.

### **Remedy C**

From gutter dust. Gutter dust often contains lane conditioner or cleaner residue. Dust removed from gutters may fall off mops during the cleaning process. Dust may also fall during the lane to lane process of shaking excess dust from the mops. Care must be taken to make sure no gutter dust drops on the approach surface. This may require the use of a cardboard box to shake the mop dust inside.

---

## **Cause 6: Contamination by Wax**

Floor tiling is often waxed and buffed for protection and appearance. Most types of wax used for this purpose transfers easily to the bowler's shoe.

### **Remedy A**

Brunswick recommends the use of a urethane-based polish that does not transfer to the bowler's shoe. One such product is Butcher's High Noon urethane floor polish. This product is buffed after application and is very shiny. Use this wax in the bowler's area, control desk area, or rest rooms, or any other tiled area where bowlers frequently walk.

---

## **Cause 7: Contamination by Carpeting**

Often, carpets and rugs contain protectants that transfer to the bowler's shoe. These protectants (for example, ScotchGuard) will transfer to the approach and resist the bowler's slide. In addition, carpets retain moisture, sugar from drinks, and dirt that cause contamination.

### **Remedy A**

New carpets should have the ScotchGuard "baked" into the fibres. If it is not baked in, the ScotchGuard should be extracted using professional cleaners. Professional cleaners can be located through the IICRC Referral System by calling 1-800-835-4624. Cleaning requires a slightly low pH solution heated to 180 degrees.

Older carpets should be cleaned monthly based on traffic and outside conditions. Visual inspection and spot cleaning should take place daily, and might be a good idea between large bowling periods during the day. Contamination can be reduced by throw rugs in entrances and in high traffic areas. Vacuuming is the most significant element in the maintenance of carpet. Research shows that 85% of soil tracked into a building is dry and the other 15% is oily.

When sealing asphalt parking lots, specify a high quality sealer to reduce transfer to customers' shoes.

Carpeting should not be installed close to the approach. The carpet tends to clean the bowler's heel, thus increasing its resistance to sliding. Carpeting should not be used in main entrances, where bowlers come in from the outside. There, moisture, dirt, and other contaminants will be trapped by carpeting. Instead, install tile covered with slip resistant throw rugs. The throw rugs can be changed often to take away moisture and dirt.

---

## Problem: Slippery Approaches

---

### Cause 1: Extremely Low Humidity

#### Remedy A

The recommended relative humidity of a bowling center is  $45\% \pm 5\%$ . If the humidity is very low, the approaches will become dry and more slippery.

---

### Cause 2: Hot Air Blowing on the Approach.

Hot air has the effect of drying the approach surface.

#### Remedy A

Avoid blowing air on the approach surface.

---

### Cause 3: Static Electricity Buildup

The humidity level is too low. As bowlers bowl, static electricity builds up in slide areas. This in turn attracts dust which creates slippery conditions.

#### Remedy A

Increase and maintain a consistent amount of moisture in the building (approximately  $45\% \pm 5\%$ ).

---

## Problem: Too Much Carry Down

#### Remedy:

To compensate for excessive carry-down, decrease the distance of the **applied oil** in the center of the lane leaving the pattern distance the same. This adjustment increases the buff distance and reduces the oil thickness at the end of the pattern. We do not recommend shortening the pattern distance because it will create a greater amount of transition on the backends. More transition forces the bowlers to make more adjustments, which means lower scores.

Carry-down is caused by the depth of the oil at the end of the oil pattern. The type of surface a center has will determine the thickness necessary. The finish on wood lanes and the wood are softer than synthetic surfaces. Carry-down is more noticeable on the synthetics than on the wood lanes. We have noticed that an oil film thickness above 15 units causes carry-down that affects the direction of the bowling ball on the backends. This affects pin carry and cause unnecessary pinsetter calls. We recommend that the oil thickness remain between 10 and 15 units at the end of the pattern especially on synthetics and 100 % Solids Urethane finishes. For wood lanes, we can increase that lane conditioner film thickness, but it should still remain less than 20 units for Water-Based and High-Solids Urethanes finishes.

---

## **Problem: Too Much Backend Reaction**

### **Remedy:**

Lengthen the pattern to “tone” down the ball reaction. Make sure that the conditioner application distance does not change, only the total pattern distance. Increasing the application distance can cause carry-down and will require further pattern adjustments to compensate for that transition (refer to “...I have too much carry-down?”).

By lengthening the pattern you can create more predictable ball reaction on the backends. Smoother reacting backends allow bowlers to make simpler adjustments when the lanes start to breakdown. However, lengthening the pattern too much may cause a reduction in “swing area”, resulting in a more difficult scoring environment. Additionally, a longer conditioner pattern will make spare shooting easier.

---

## **Problem: Not Enough Hold**

### **Remedy:**

Hold is created by the length and amount of oil in the “mid-lane” (20-32 ft.). This is done by applying oil in the mid-lane on the reverse pass of the lane machine.

Lengthening the reverse application distance creates hold oil which allows the ball to more consistently guide to the break point. This creates a greater margin of error for the bowlers. Use caution when making this adjustment. Only lengthen the reverse oil application distance by a maximum of two feet at a time. Avoid adding oil on the forward pass. This can lead to carry-down. (Example: 24 feet reverse application does not provide adequate hold.....change that distance to 26 feet).

---

## **Problem: Heads Hook Too Much**

### **Remedy:**

Two things cause the heads to hook:

1. Not enough oil applied to the head area.
2. The physical condition of the heads.

To increase the volume of oil in the heads, slow the machine down on the reverse pass. This allows the machine to distribute more conditioner in the area it needs oil to provide a more stable impact zone.

Due to the travel direction of the machine and the rotation of the buffer brush, the oil application is slightly thicker on the reverse application than on the forward application.

***NOTE:** Sometimes the heads get confused with the mid-lane. When standing at the foul line, the perception of the bowler is much different than standing further back or off to the side. The ball should spend very little time in the first 15-20 feet of the lane. If the heads do hook it will force the ball to “read” the lane earlier, violating basic ball reaction principles creating an unfair and less entertaining bowling environment.*

---

## **Problem: Not Enough Swing Area**

### **Remedy :**

A lack of swing area can be caused by two things. Too much oil applied to the outside boards or a “crowned” lane topography. Reduce the amount of oil on the outside boards if there is too much. If topography is the problem, contact your professional lane resurfacers to correct the wood lane or synthetic panel topography problem. There are two ways of handling a crowned lane surface:

1. Shift the pattern deeper inside the lane and reduce the amount of crosswise blend of the oil pattern.
2. Widen the pattern slightly and increase the volume of oil applied to the track area on the return.

Crowned lanes guide the ball to the gutter and make the ball more sensitive to speed when you cross boards. By narrowing the pattern (moving the track further inside) you can move the break point further inside. More friction (less oil) is created on the outside where topography issues once worked against the ball “turning the corner”. This creates a “swing zone” so that if the bowler misses by one board while playing across the lane in the front, there is a greater chance of recovery to the pocket. By widening the pattern (moving the track further out) you force the bowlers to play more direct with the lane (straighter). By doing this, the bowler’s trajectory and ball speed become less sensitive to the conditioner pattern and lane surface. This increases the margin for error at the break point.

---

## **Problem: Track Dries Up Too Quickly**

### **Remedy:**

The mid-lane ball track can hook if there is not enough oil or if there is too much oil. This can be determined by looking at the pattern settings along with Computer Lane Monitor graphs. If there is not enough oil then more should be applied to the mid-lane on the return pass. By using the return pass we are able to maintain control over the end of the pattern and the stability of the breakpoint. If there is too much oil, then speed increases and maybe a reduction of oil is needed on the reverse pass.

The mid-lane is one of the most important parts of the lane for creating a “stable” scoring environment. Too much oil both in the heads and the mid-lane can cause the ball to slow down too quickly. When the ball slows too quickly, the dynamics of the ball will take effect sooner and also allow the ball to remove a greater amount of conditioner. Once the mid-lane is broken down, it makes bowler adjustments much trickier. More direct bowlers will make an adjustment to compensate for early hook. The ball then becomes unstable at the breakpoint, while the bowlers playing deeper inside are unaffected and gain an advantage.

## Section 5: Lane Maintenance Schedule

---

### General Maintenance Schedule

There are many items related to lanes that require routine scheduled maintenance. To serve as a reminder of the maintenance that must be performed, a list of the routine maintenance items and a schedule of lane responsibilities follow.

---

#### Daily Maintenance

1. Dust caps and gutters
2. Dust lanes
3. Dust approaches
4. Dust ball hood and rack
5. Clean lane and pin deck
6. Condition lanes
7. Clean lane machine
8. Spot clean approaches
9. Inspect Approaches
10. Wash soiled laundry
11. Clean and polish house balls, as required
12. Clean hoods and rack

---

#### Weekly Maintenance

1. Clean bowler seating
2. Buff synthetic approaches
3. Change carpet covers
4. Change pin dusters
5. Change ball wipes
6. Clean bowler seating

(A) 25% of all the equipment to schedule

---

#### Monthly Maintenance

1. Dust masking units
2. Clean upper overheads
3. Clean lower consoles
4. Vacuum hand dryers
5. Clean flat gutters
6. Clean kickbacks
7. Vacuum ball lifts
8. Inspect lanes
9. Inspect pit ends, screws plugs, and joints
10. Clean caps and gutter

(A) 25% of all the equipment per week

## LANE PREVENTIVE MAINTENANCE SCHEDULE DAILY, WEEKLY, AND MONTHLY

Day of Month Month: _____	Code	1	2	3	4	5	6	7	8	9	10	11	12	13	14	15	16	17	18	19	20	21	22	23	24	25	26	27	28	29	30	31				
Dust Masking Units																																				
Dust Caps and Gutters																																				
Clean Caps and Gutters	AS																																			
Dust Lanes																																				
Dust Approaches																																				
Dust Ball Hoods/Racks																																				
Clean Upper Overheads	A																																			
Clean Lower Consoles	A																																			
Clean lanes/Pindecks																																				
Condition Lanes																																				
Clean Lane Machine																																				
Spot Clean Approaches																																				
Vacuum Hand Dryers	A																																			
Clean Hoods and Racks																																				
Clean Bowler Seating	A																																			
Buff Synthetic Approach																																				
Clean Flat Gutters	A																																			
Clean Kickbacks	A																																			
Change Carpet Covers	A																																			
Change Pin Dusters	A																																			
Change Ball Wipes	A																																			
Vacuum Ball Lifts	A																																			
Inspect Approaches																																				
Inspect Lanes																																				
Inspect Pit Ends	A																																			
Wash Soiled Laundry																																				
Clean /Polish House Balls	AS																																			

**KEY CODES:**  
 (A) 25% Of All Equipment  
 (AS) As Needed

