

Symmetric Layouts 2007

- **Maximum Hook & Arc**
 - Good for most House Shots
- **Mid-Lane Hook & Back-End**
 - A favorite for fresh PBA and Sport Conditions
- **Length & Back-End**
 - A favorite for broken down PBA and Sport Conditions
- **Length**
 - Good for most broken down House Shots
- **Full Roller Options**

Maximum Hook & Arc

Symmetric Core - RGdiff - 0.040 or greater

- Best pin out distance to use: 0 – 2 inches
- Pin from axis (A) : 4 – 4 ½ inches
- Before drilling, the ball should balance around ¾ positive side so that you can fine tune with an X - hole if needed.
- To fine tune with an X – hole please see our attached drilling instructions.
- Rev's up early for maximum hook with a continuous back-end.

Medium Track

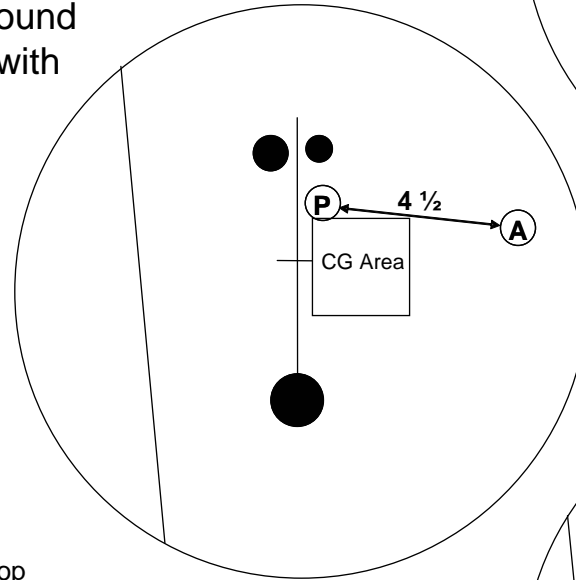

High Track

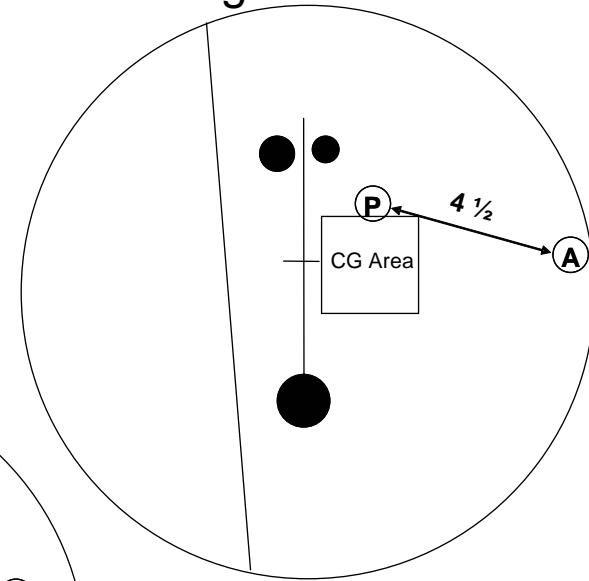

Low Track

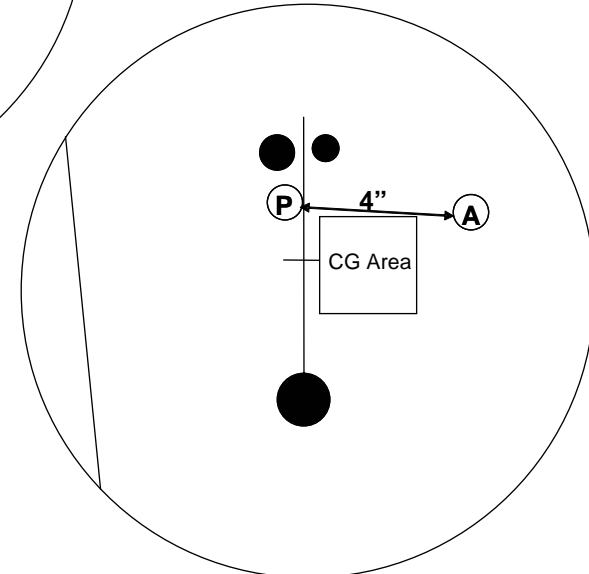

1. (P) is the larger circle or pin on the ball that marks the top of the core.
 2. For left-handed bowlers use the mirror images of these layouts.
- Note: Finger, thumb and X-holes must have at least a moderate bevel and the riser Pin (P) must be at least one inch from any drilled hole to comply with the Brunswick warranty.

Mid-Lane Hook & Back-End

Symmetric Core - RGdiff - 0.040 or greater

- Best pin out distance to use: 2 – 4 inches
- Pin from axis (A) : 5 – 5 ½ inches
- Before drilling, the ball should balance between ¾ and 1 ½ thumb and positive side. Both thumb and side should weigh close to the same amount.
- X-hole size should be 1 1/8 X 2 ½ deep.
- This layout helps bowlers open up the mid-lane and recover on heavy carry down.

1. (P) is the larger circle or pin on the ball that marks the top of the core.
 2. (X) is where to drill the X-hole on the ball.
 3. For left-handed bowlers use the mirror images of these layouts.
- Note: Finger, thumb and X-holes must have at least a moderate bevel and the riser Pin (P) must be at least one inch from any drilled hole to comply with the Brunswick warranty.

Medium Track

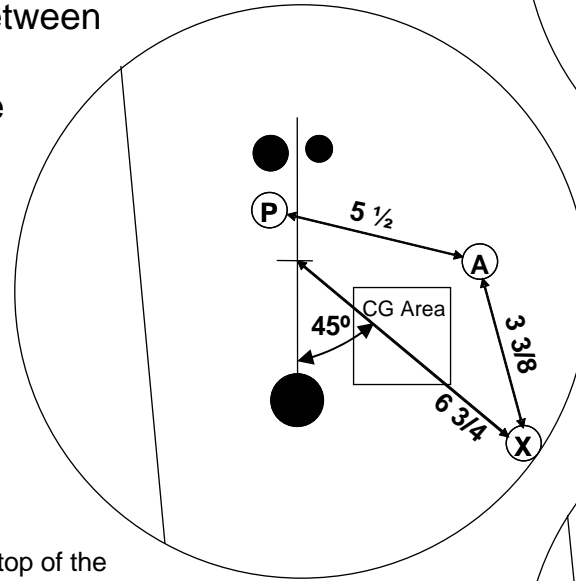

High Track

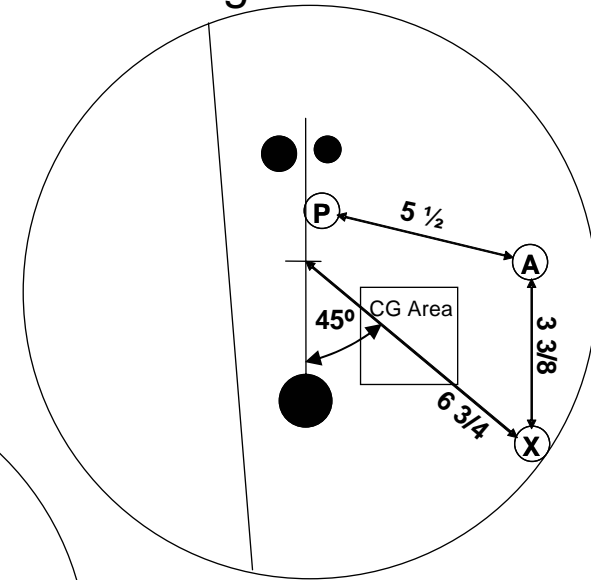

Low Track

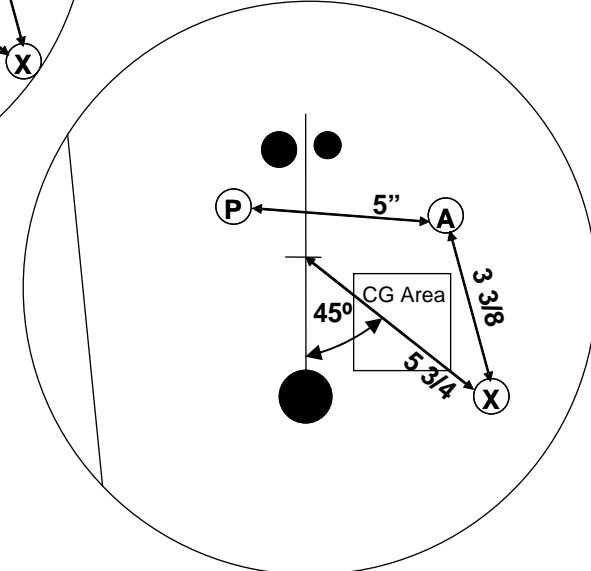

Length & Back-End

Symmetric Core - RGdiff - 0.040 or greater

- Best pin out distance to use: $3\frac{1}{2}$ – $5\frac{1}{2}$ inches
- Pin from axis (A) : 5 – $5\frac{1}{2}$ inches
- Before drilling, the ball should balance between $\frac{3}{4}$ and $1\frac{1}{2}$ thumb and positive side. Both thumb and side should weigh close to the same amount.
- X-hole size should be $1\frac{1}{8}$ X $2\frac{1}{2}$ deep.
- This layout helps bowlers create length with a strong back-end

Medium Track

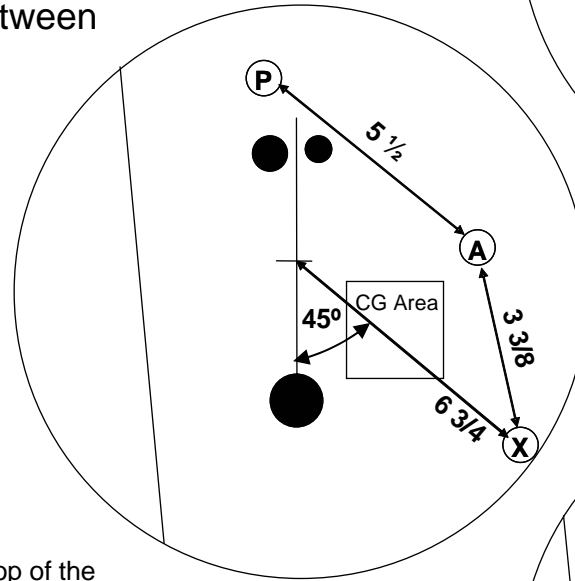

High Track

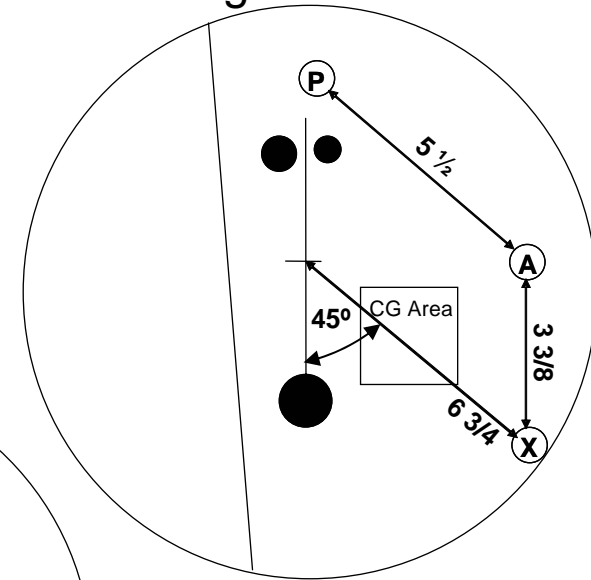

Low Track

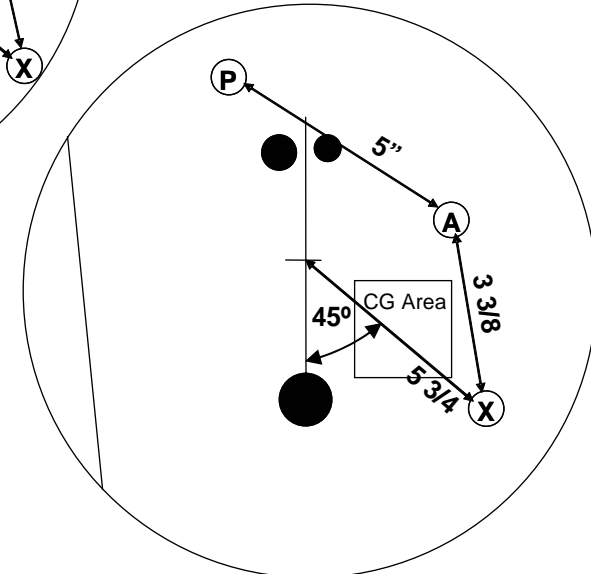

1. (P) is the larger circle or pin on the ball that marks the top of the core.
 2. (X) is where to drill the X-hole on the ball.
 3. For left-handed bowlers use the mirror images of these layouts.
- Note: Finger, thumb and X-holes must have at least a moderate bevel and the riser Pin (P) must be at least one inch from any drilled hole to comply with the Brunswick warranty.

Length

Symmetric Core - RGdiff - 0.040 or greater

- Best pin out distance to use: 3 – 5 ½ inches
- Pin from axis (A) : 5 – 5 ½ inches
- Before drilling, the ball should balance around ¾ positive side so that you can fine tune with an X - hole if needed.
- To fine tune with an X – hole please see our attached drilling instructions.
- Length drilling with arcing back-end

Medium Track

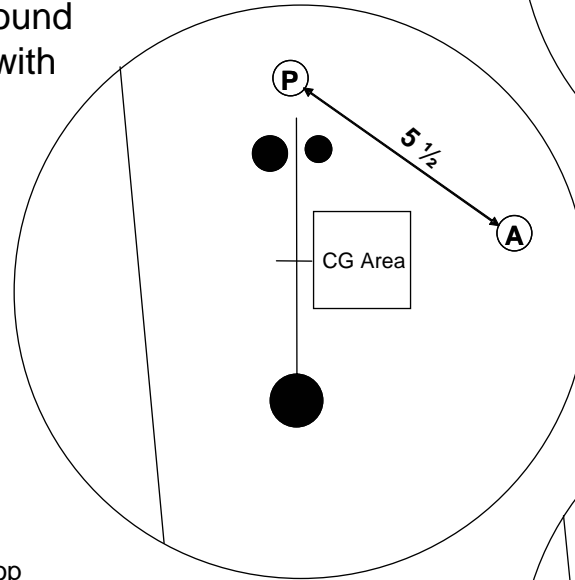

High Track

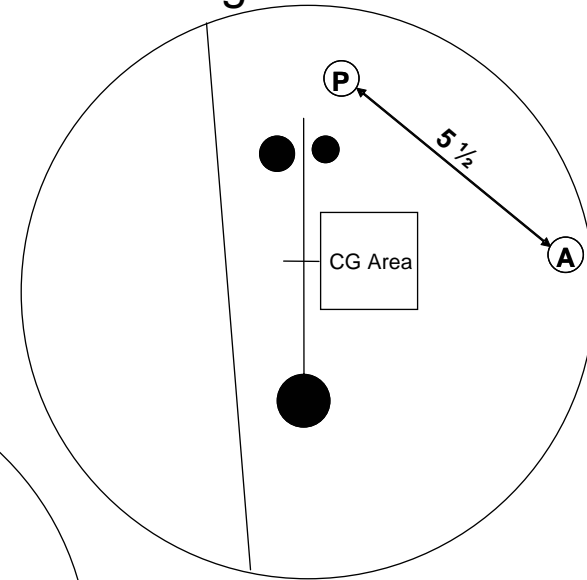

Low Track

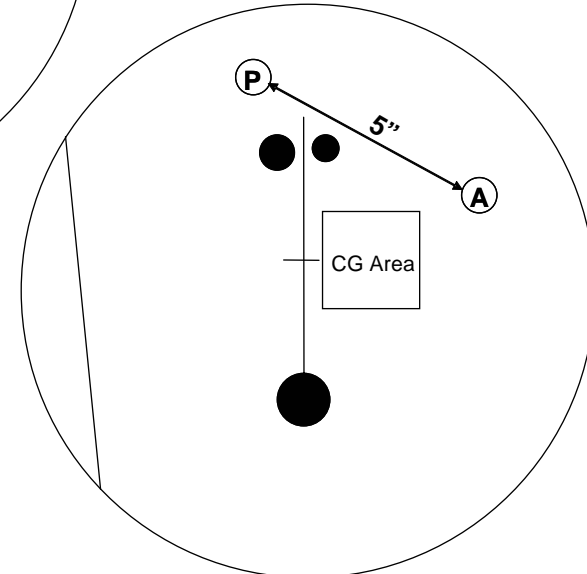

1. (P) is the larger circle or pin on the ball that marks the top of the core.
 2. For left-handed bowlers use the mirror images of these layouts.
- Note: Finger, thumb and X-holes must have at least a moderate bevel and the riser Pin (P) must be at least one inch from any drilled hole to comply with the Brunswick warranty.

Maximum Hook & Arc – Full Roller

Symmetric Core - RGdiff - 0.040 or greater

- Best pin out distance to use: 2 – 3 ½ inches
- Pin from grip center : 3 inches @ 60°
- The Basic Full Roller Drilling that won't over flare for most Bowlers.
- This layout will give the bowler maximum hook with a smooth back-end.

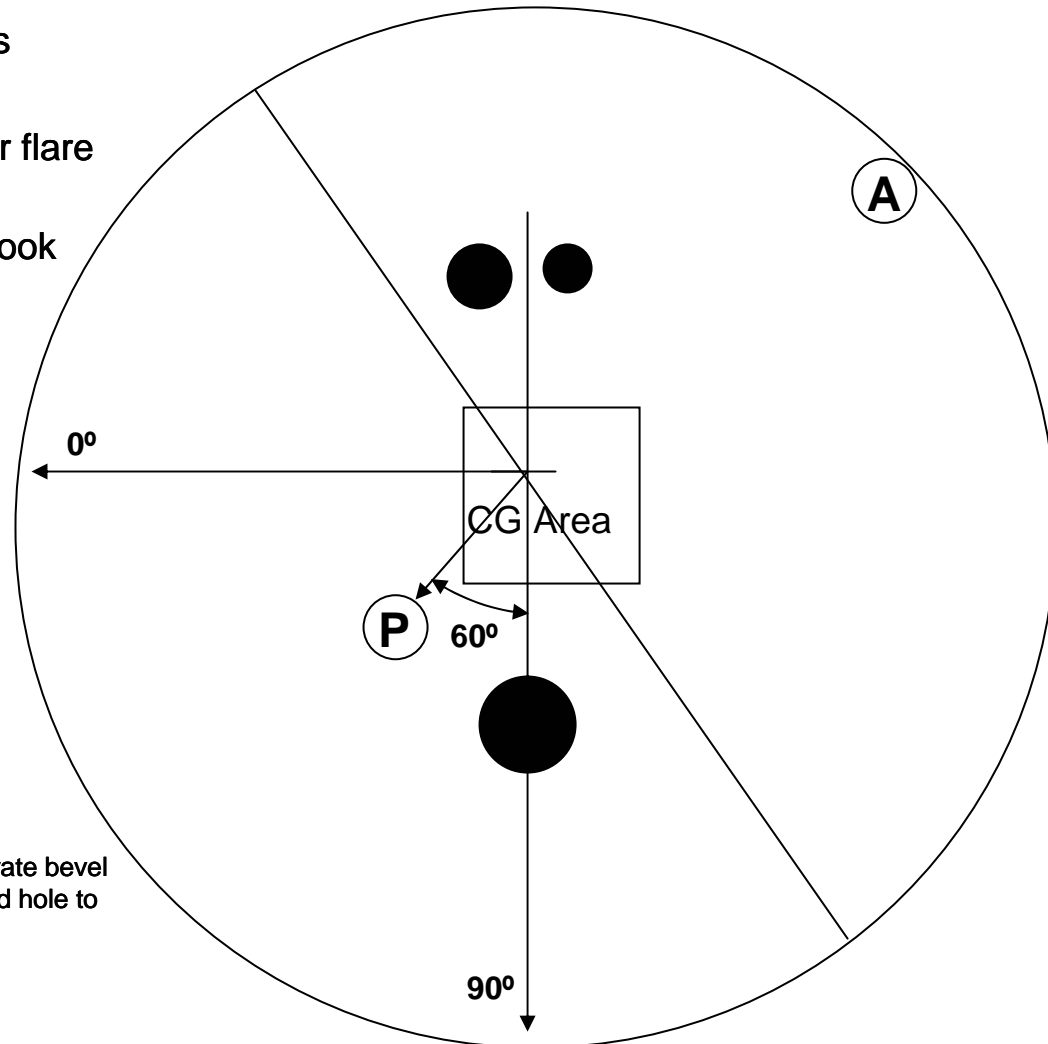

- 1. **P** is the larger circle or pin on the ball that marks the top of the core.
- 2. For left-handed bowlers use the mirror images of these layouts.
- Note: Finger, thumb and X-holes must have at least a moderate bevel and the riser Pin **P** must be at least one inch from any drilled hole to comply with the Brunswick warranty.

Mid-Lane Hook & Back-End – Full Roller

Symmetric Core - RGdiff - 0.040 or greater

- Best pin out distance to use: 4 – 5 ½ inches
- Pin from grip center : 3 inches @ 60°
- Before drilling, the ball should balance between 1½ and 2 ½ ounces of Finger weight.
- X-hole size should be 1 1/8 X 2 ½ deep.
- Rev's up early for maximum hook with and strong arcing back-end.

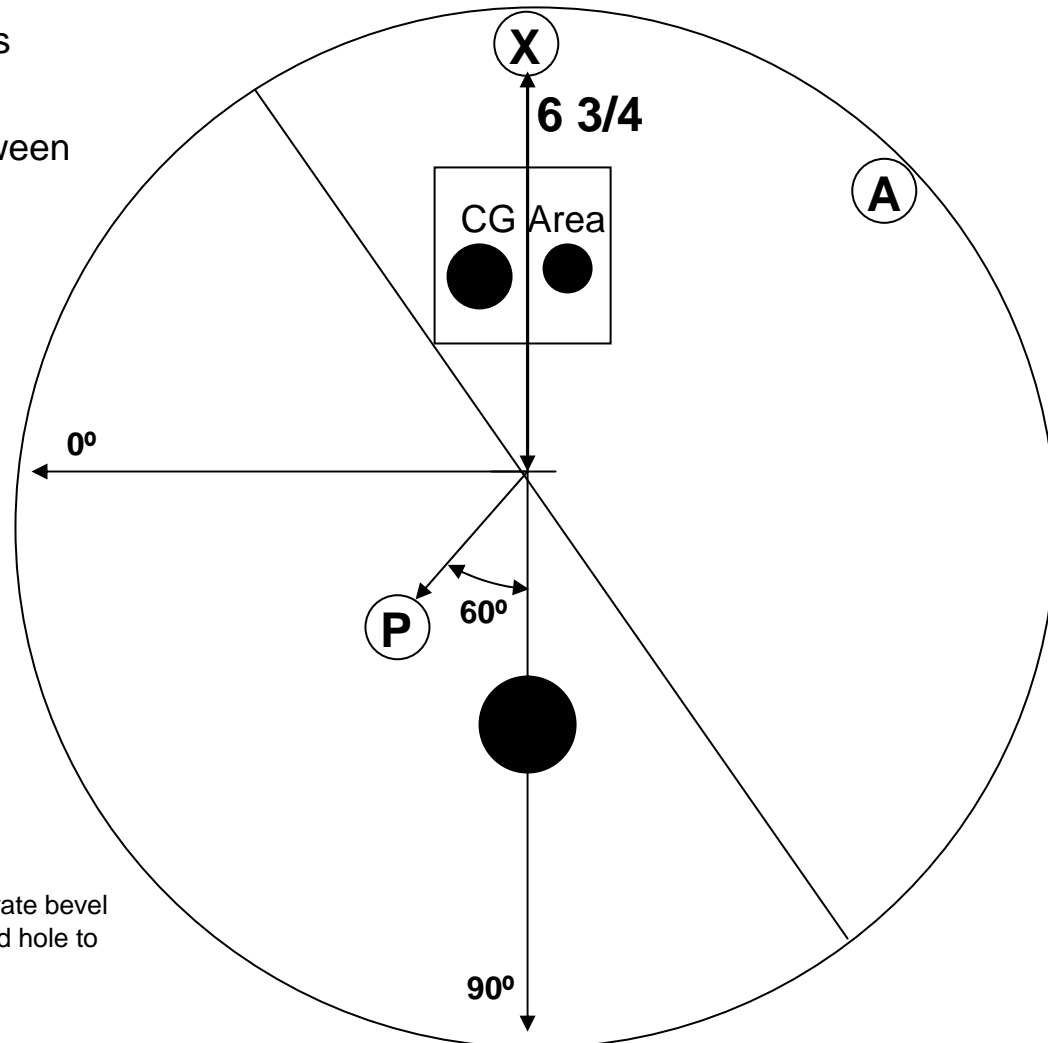

- 1. **(P)** is the larger circle or pin on the ball that marks the top of the core.
- 2. **(X)** is where to drill the X-hole on the ball.
- 3. For left-handed bowlers use the mirror images of these layouts.
- Note: Finger, thumb and X-holes must have at least a moderate bevel and the riser Pin **(P)** must be at least one inch from any drilled hole to comply with the Brunswick warranty.

Length & Back-End – Full Roller

Symmetric Core - RGdiff - 0.040 or greater

- Best pin out distance to use: 3 – 5 ½ inches
- Pin from grip center : 1 ½ inches @ 60°
- Before drilling, the ball should balance between 1 and 2 ounces of Finger weight.
- X-hole size should be 31/32 X 2 ½ deep.
- This layout helps bowlers create length with a strong arcing back-end.

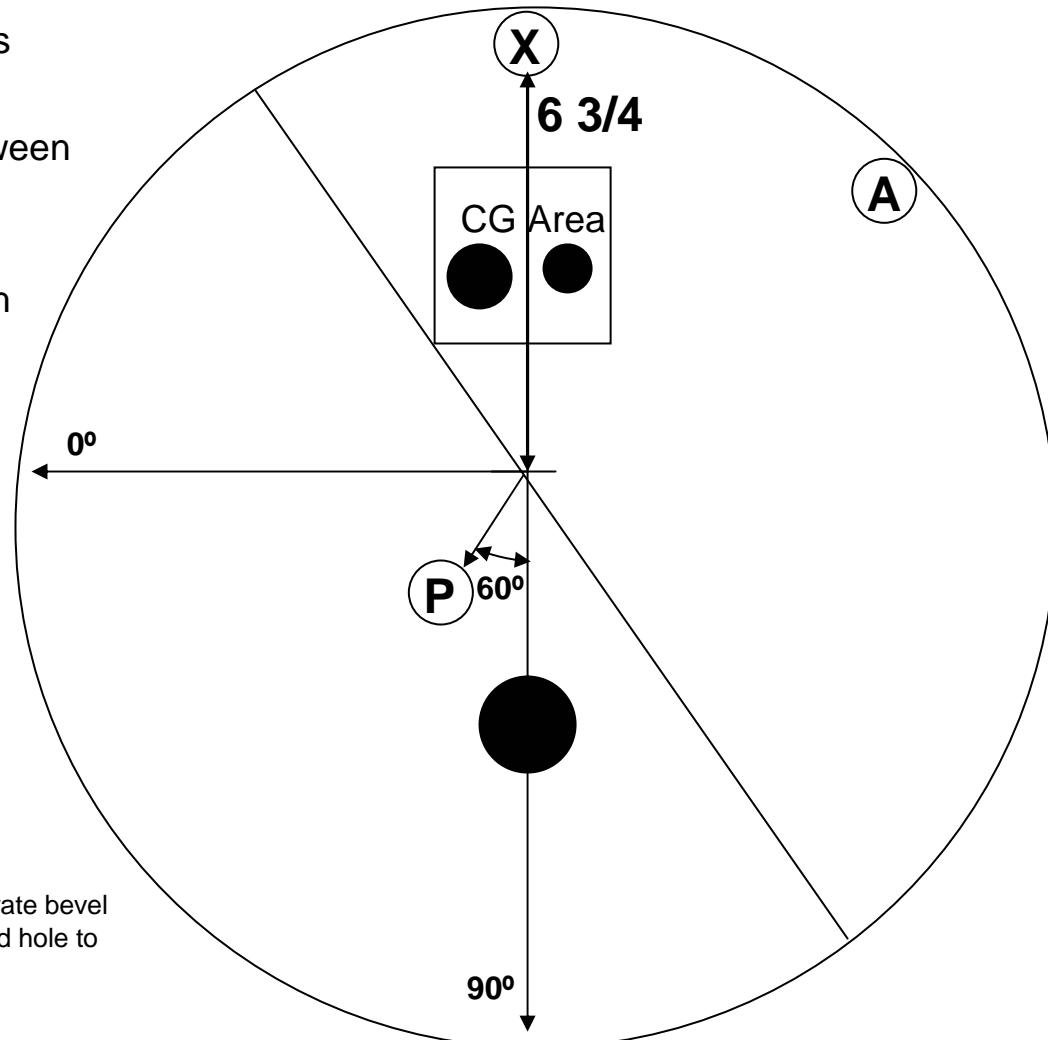

1. **(P)** is the larger circle or pin on the ball that marks the top of the core.
 2. **(X)** is where to drill the X-hole on the ball.
 3. For left-handed bowlers use the mirror images of these layouts.
- Note: Finger, thumb and X-holes must have at least a moderate bevel and the riser Pin **(P)** must be at least one inch from any drilled hole to comply with the Brunswick warranty.

Asymmetric Layouts 2007

- **Maximum Hook & Arc**
 - Good for most House Shots
- **Mid-Lane Hook & Back-End**
 - A favorite for fresh PBA and Sport Conditions
- **Length & Back-End**
 - A favorite for broken down PBA and Sport Conditions
- **Length**
 - Good for most broken down House Shots
- **Full Roller Options**

Maximum Hook & Arc

Asymmetric Core

RGdiff - 0.040 or greater

Asy RGdiff - 0.015 - 0.030

- Best pin out distance to use: 0 - 2 inches
- Pin from axis (A): 4 - 4 ½ inches
- Locator Pin set at 60°
- Rev's up early for maximum hook with a continuous back-end.

Medium Track

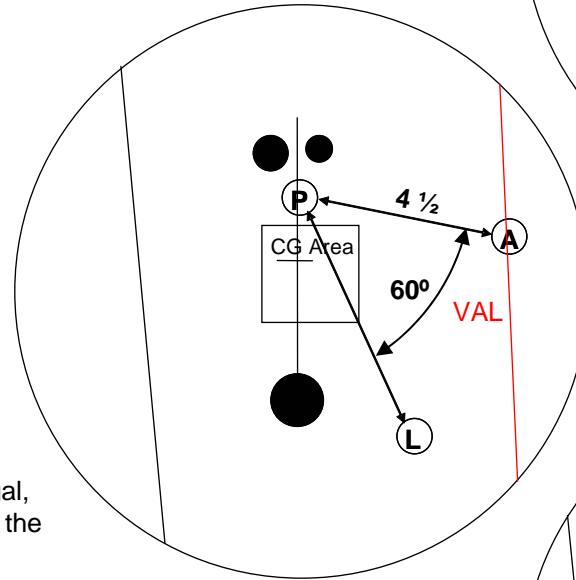

High Track

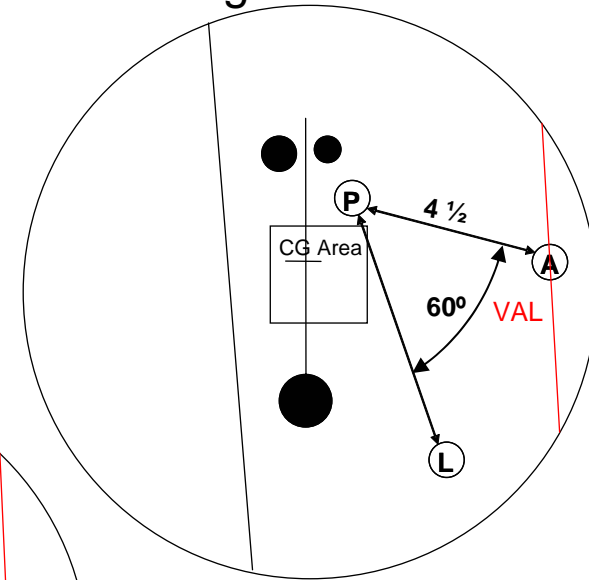

Low Track

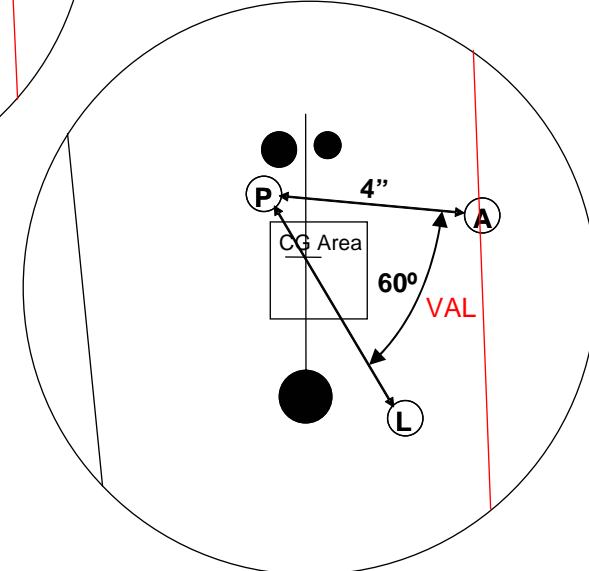

- Note: If an X-hole is necessary to make the ball USBC legal, draw a line from the grip center through the CG and place the X-hole where it hits the VAL.
 1. (P) is the larger circle or pin on the ball that marks the top of the core.
 2. (L) is a smaller circle or pin that marks the Preferential Spin Axis (PSA) of the ball.
 3. For left-handed bowlers use the mirror images of these layouts.
- Note: Finger, thumb and X-holes must have at least a moderate bevel and the riser Pin (P) must be at least one inch from any drilled hole to comply with the Brunswick warranty.

Mid-Lane Hook & Back-End

Asymmetric Core

RGdiff - 0.040 or greater

Asy RGdiff - 0.015 - 0.030

- Best pin out distance to use: 0 - 2 inches
- Pin from axis (A): 5 - 5 ½ inches
- Locator Pin set at 45°
- This layout helps bowlers open up the mid-lane and recover on the heavy carry down.

Medium Track

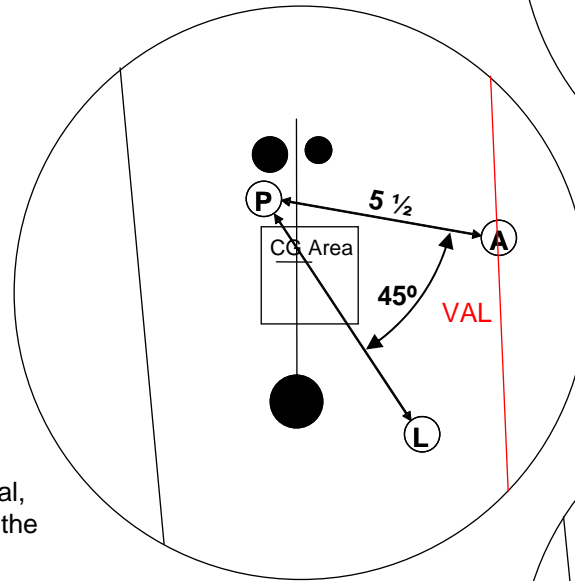

High Track

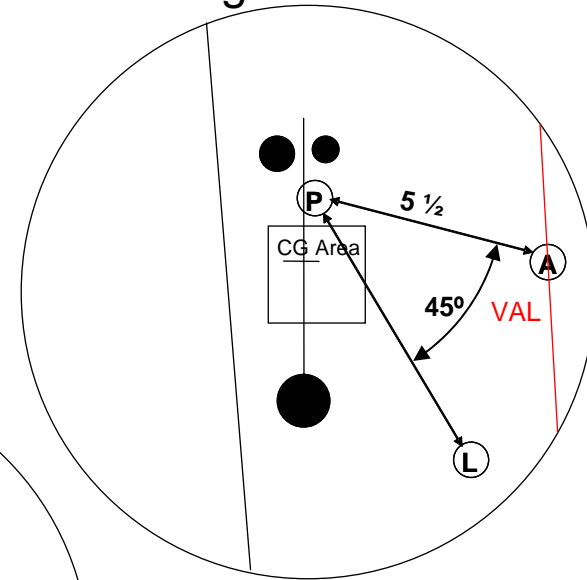

Low Track

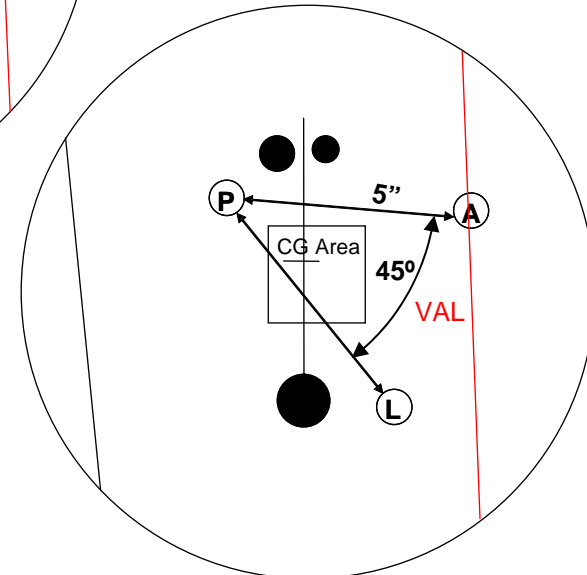

- Note: If an X-hole is necessary to make the ball USBC legal, draw a line from the grip center through the CG and place the X-hole where it hits the VAL.
 1. (P) is the larger circle or pin on the ball that marks the top of the core.
 2. (L) is a smaller circle or pin that marks the Preferential Spin Axis (PSA) of the ball.
 3. For left-handed bowlers use the mirror images of these layouts.
- Note: Finger, thumb and X-holes must have at least a moderate bevel and the riser Pin (P) must be at least one inch from any drilled hole to comply with the Brunswick warranty.

Length & Back-End

Asymmetric Core

RGdiff - 0.040 or greater

Asy RGdiff - 0.015 - 0.030

- Best pin out distance to use: 3 ½ - 5 ½ inches
- Pin from axis (A): 5 - 5 ½ inches
- Locator Pin set at 45°
- This layout helps bowlers create length with a strong back-end.

Medium Track

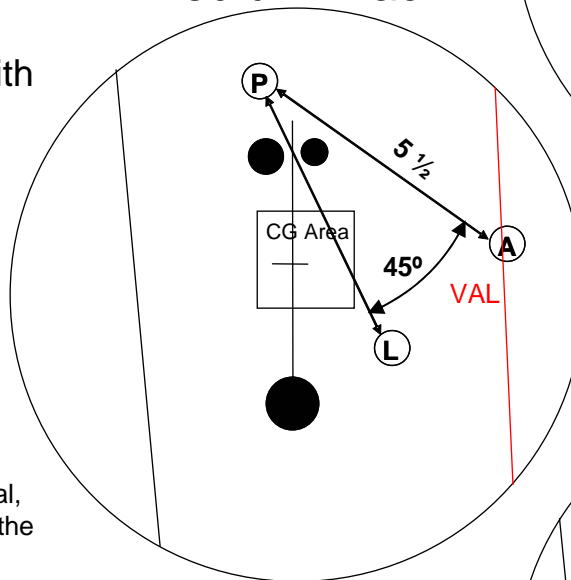

High Track

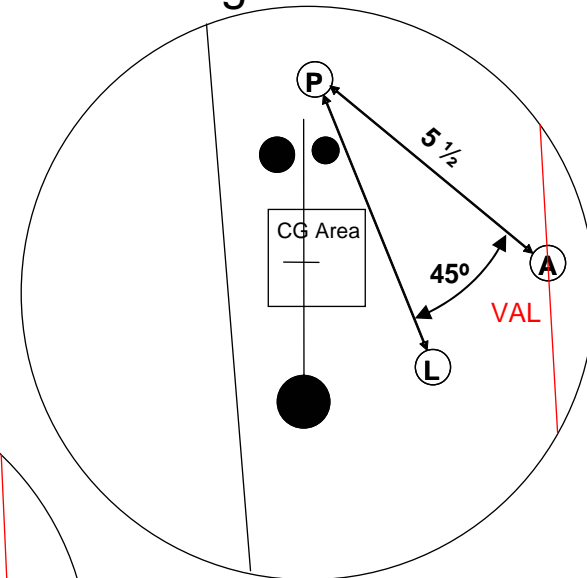

Low Track

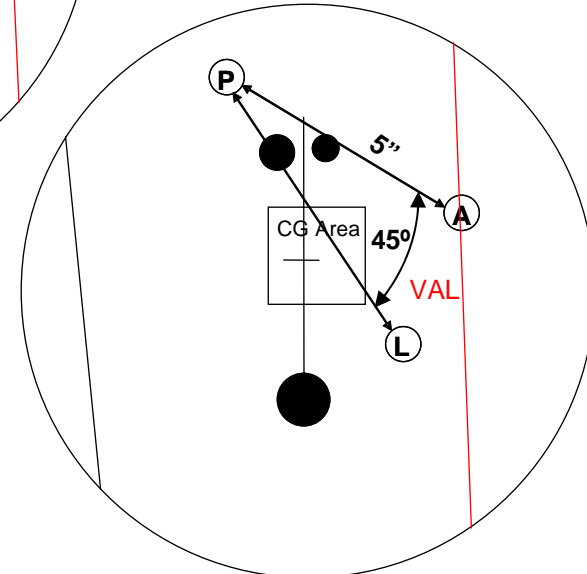

- Note: If an X-hole is necessary to make the ball USBC legal, draw a line from the grip center through the CG and place the X-hole where it hits the VAL.
 1. (P) is the larger circle or pin on the ball that marks the top of the core.
 2. (L) is a smaller circle or pin that marks the Preferential Spin Axis (PSA) of the ball.
 3. For left-handed bowlers use the mirror images of these layouts.
- Note: Finger, thumb and X-holes must have at least a moderate bevel and the riser Pin (P) must be at least one inch from any drilled hole to comply with the Brunswick warranty.

Length

Asymmetric Core

RGdiff - 0.040 or greater

Asy RGdiff - 0.015 - 0.030

- Best pin out distance to use: 3 - 5 ½ inches
- Pin from axis (A): 5 - 5 ½ inches
- Locator Pin set at 60°
- Length drilling with arcing back-end.

Medium Track

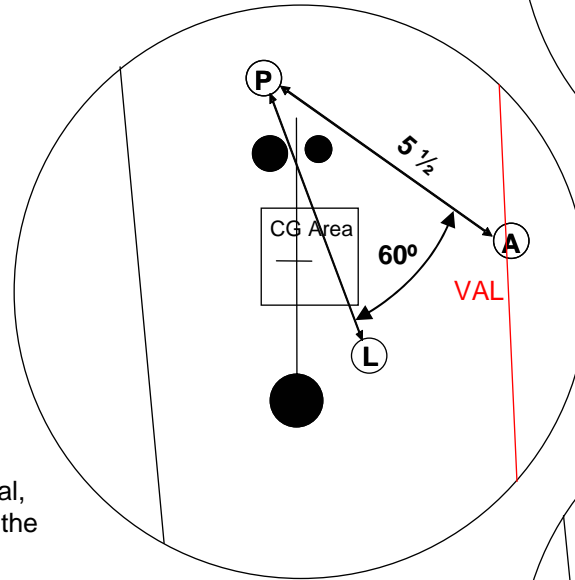

High Track

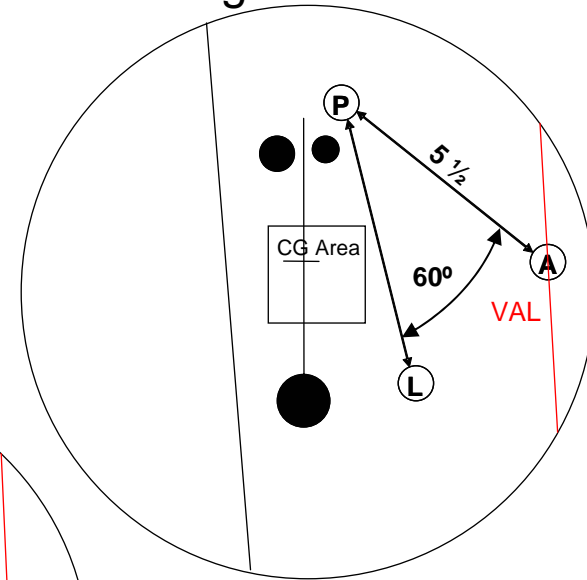

Low Track

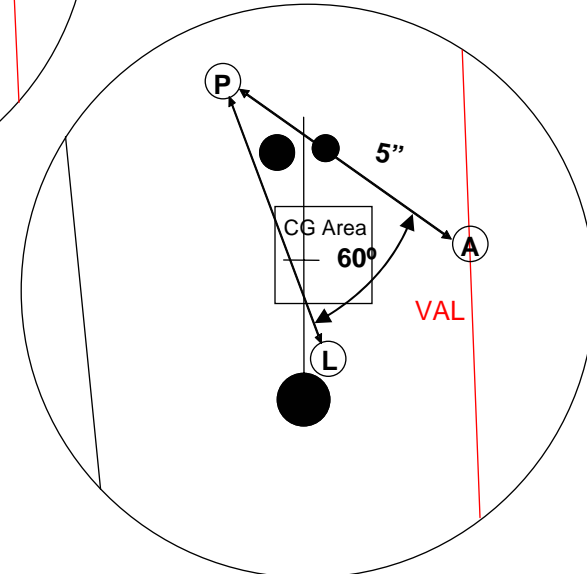

- Note: If an X-hole is necessary to make the ball USBC legal, draw a line from the grip center through the CG and place the X-hole where it hits the VAL.
 1. (P) is the larger circle or pin on the ball that marks the top of the core.
 2. (L) is a smaller circle or pin that marks the Preferential Spin Axis (PSA) of the ball.
 3. For left-handed bowlers use the mirror images of these layouts.
- Note: Finger, thumb and X-holes must have at least a moderate bevel and the riser Pin (P) must be at least one inch from any drilled hole to comply with the Brunswick warranty.

Maximum Hook and Arc – Full Roller

Asymmetric Core

RGdiff - 0.040 or greater

Asy RGdiff - 0.015 - 0.030

- Best pin out distance to use: 2 - 4 inches
- Pin from grip center : 3 inches
- Locator Pin set at 45°
- Rev's up early for maximum hook with and strong arcing back-end.

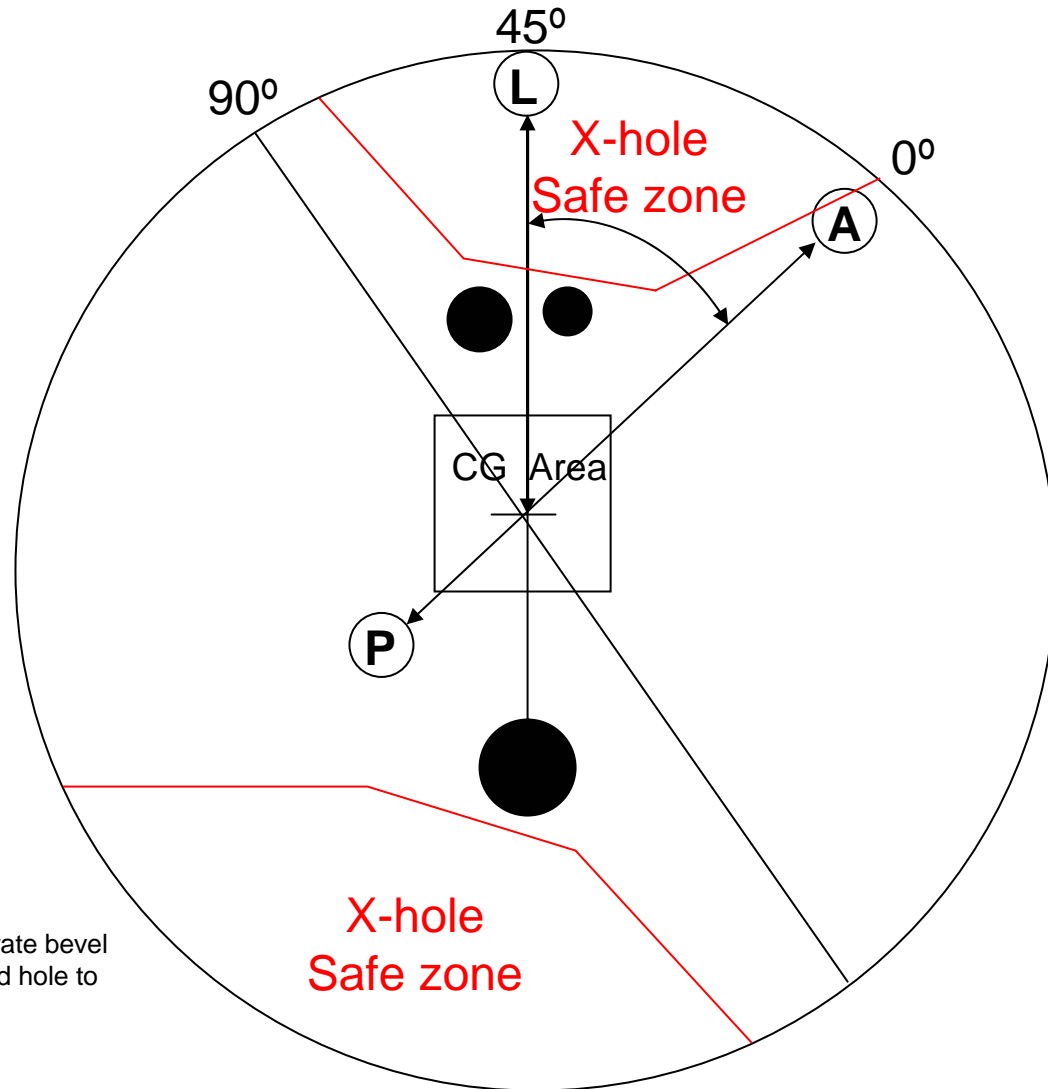

- Note: If an X-hole is needed place it in the X-hole safe zone 6" from center of grip to avoid contact with the track.
 1. (P) is the larger circle or pin on the ball that marks the top of the core.
 2. (L) is a smaller circle or pin that marks the Preferential Spin Axis (PSA) of the ball.
 3. For left-handed bowlers use the mirror images of these layouts.
- Note: Finger, thumb and X-holes must have at least a moderate bevel and the riser Pin (P) must be at least one inch from any drilled hole to comply with the Brunswick warranty.

Length & Back-End – Full Roller

Asymmetric Core

RGdiff - 0.040 or greater

Asy RGdiff - 0.015 - 0.030

- Best pin out distance to use: 0 - 3 inches
- Pin from grip center : 2 inches
- Locator Pin set at 60°
- This layout helps bowlers create length with a strong back-end.

- Note: If an X-hole is needed place it in the X-hole safe zone 6" from center of grip to avoid contact with the track.
 1. (P) is the larger circle or pin on the ball that marks the top of the core.
 2. (L) is a smaller circle or pin that marks the Preferential Spin Axis (PSA) of the ball.
 3. For left-handed bowlers use the mirror images of these layouts.
- Note: Finger, thumb and X-holes must have at least a moderate bevel and the riser Pin (P) must be at least one inch from any drilled hole to comply with the Brunswick warranty.

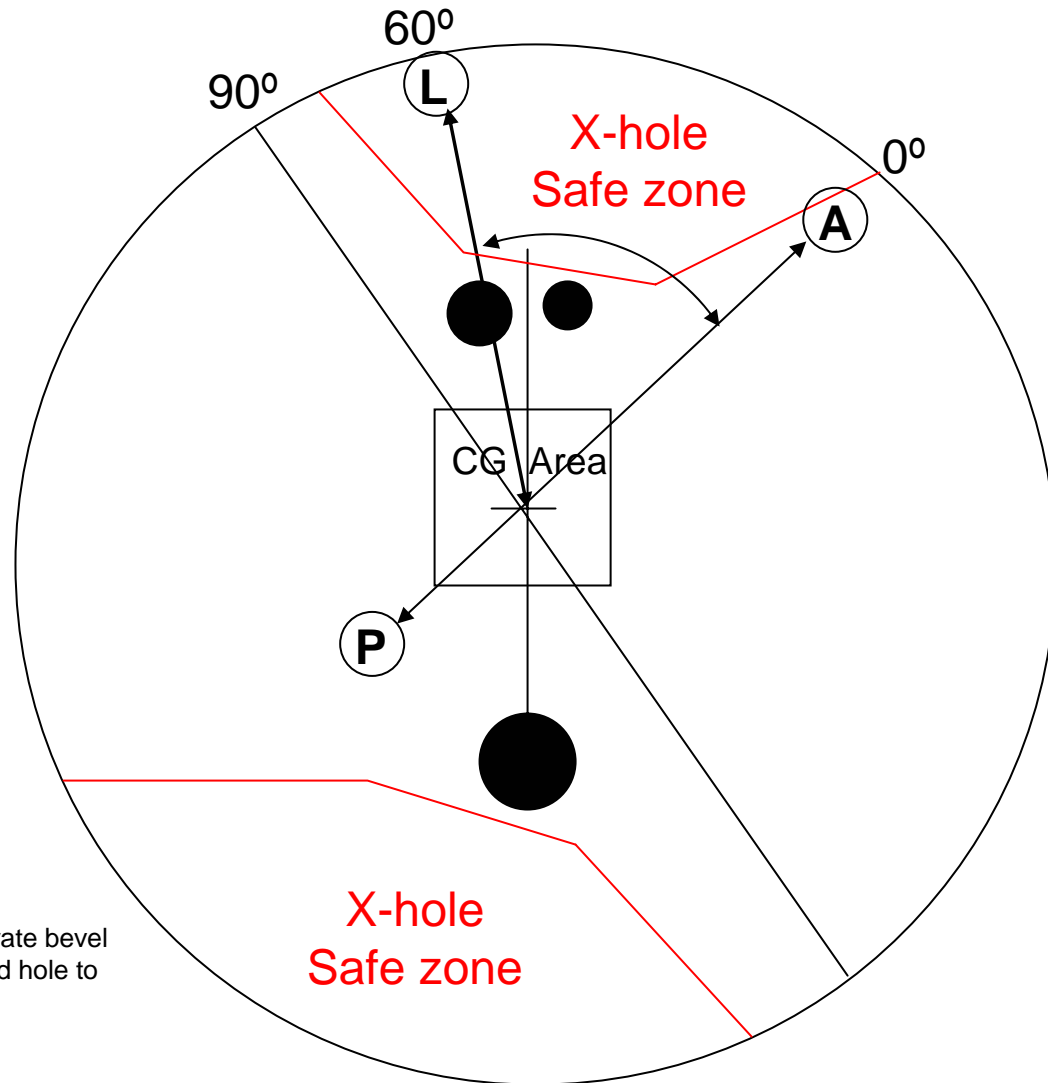

Length – Full Roller

Asymmetric Core

RGdiff - 0.040 or greater

Asy RGdiff - 0.015 - 0.030

- Best pin out distance to use: 0 - 3 inches
- Pin from grip center : 2 inches
- Locator Pin set at 0°
- Length drilling with arcing back-end.

- Note: If an X-hole is needed place it in the X-hole safe zone 6" from center of grip to avoid contact with the track.
 1. (P) is the larger circle or pin on the ball that marks the top of the core.
 2. (L) is a smaller circle or pin that marks the Preferential Spin Axis (PSA) of the ball.
 3. For left-handed bowlers use the mirror images of these layouts.
- Note: Finger, thumb and X-holes must have at least a moderate bevel and the riser Pin (P) must be at least one inch from any drilled hole to comply with the Brunswick warranty.

